

STEINHEIL-TELE-QUINAR

F 4.5, 300 mm

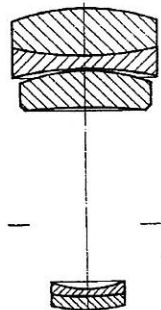

The f/4.5, 300 mm Tele-Quinar with preset diaphragm is an extraordinary telephoto lens. It has a 5 element lens system with an 8° angle of view. The lens is corrected to a high degree, making it a 'preferred' lens for color photography. For outdoor shots, nature, bird, sports, and marine work, the lens will perform with outstanding results. Diaphragm closes down to f/32. Finished in ebony and chrome mount.

Price

\$ 299.50

Filter size series 9

list

Steinheil Optical Works, Munich, Germany, was founded 140 years ago by the most brilliant optical scientist of his time, C. A. Steinheil. Since its inception, scientific progress and service to the field of photography was its chief goal. Today, Steinheil ranks as the foremost producer of instant-reopen automatic diaphragm lenses for 35 mm cameras.

Steinheil lenses are highly corrected to produce the finest results with color and black and white film. Each Steinheil lens was developed to meet a definite need. Perfection, precision and attention to the minutest detail is constantly maintained at every step of the manufacturing process. All these controls have but one object... to create lenses that will guarantee years of picture-taking perfection for you.

Your dealer will be glad to demonstrate the complete line of Steinheil lenses to you. Be sure to see him today!

OPTISCHE WERKE C. A. STEINHEIL
Munich 8 - Germany

U. S. A. Factory Representative
CAMERA SPECIALTY COMPANY, Inc.
Bronxville, New York

In Canada:
EXAKTA CAMERA COMPANY
579 Richmond Street West, Toronto, Ontario

Printed in Holland

STEINHEIL AUTOMATIC LENSES

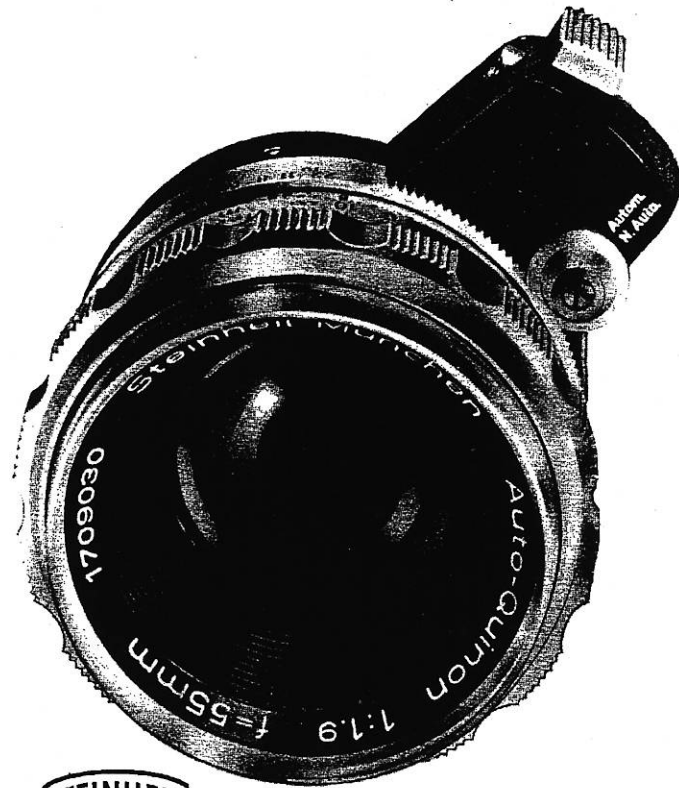

STEINHEIL
OPTIK

STEINHEIL

Continuous Focusing

with Exakta and the

New STEINHEIL

AUTOMATIC LENSES



Over 140 years of

continuous progress in

optics for photography

AUTO-QUINARON

F 2.8, 35 mm

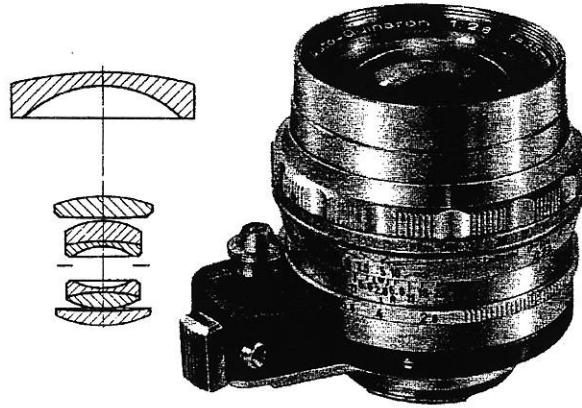

The renowned 7-element f/2.8 Auto-Quinaron 35 mm Wide Angle lens has an instant-reopen automatic diaphragm. It focuses from infinity down to 4 1/2 inches from the front element of the lens to the subject. Does not require bellows extensions or extension tubes for closeups. The angle of view is 62°, smallest of 7 diaphragm stops is f/22. Lens can also be operated manually if desired.

Special Steinheil No. 70 Sunshade, \$ 3.95. Takes series 7 filters (no adapter) when used with Steinheil 70 Sunshade (slip-on). With other makes, this lens takes series 8 adapter and filters.

Price
\$ 149.50
list

AUTO-QUINON

F1.9, 55 mm

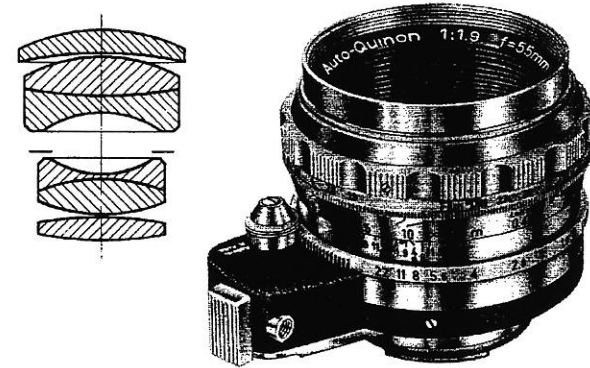

The sensational, f/1.9, 55 mm Auto-Quinon lens with instant-reopen automatic diaphragm is a completely new, fast-speed objective. Developed on the principle of the Gauss lens, the Auto-Quinon consists of 6-elements, two of which are cemented together. Outstanding correction and performance, highest possible definition and perfectly balanced contrast is assured for both color and black & white photography. The Auto-Quinon focuses down to 1.35 feet. The diaphragm closes down to f/22. Angle of view is 43°. Lens works on both automatic and manual settings. Leather case \$ 6.95. Filter size series 7

Price
\$ 140.00
list

AUTO-QUINAR

F 3.5, 100 mm

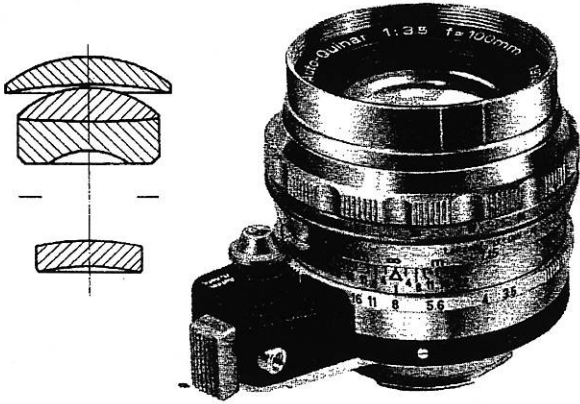

The fascinating f/3.5, 100 mm Auto-Quinar with instant-reopen automatic diaphragm is a true telephoto objective. It assures exceptional light intensity, unique brilliance, and needle-sharp critical definition. This lens combines the features of a normal and a telephoto lens, making it most desirable where natural proportions and perspective are essential. The angle of view is 27°. The diaphragm stops down to f/32; focuses from infinity to 3.8 feet. Lens operates both automatically and manually.

Leather case and sunshade furnished at no additional charge.

Filter size series 7

Price
\$ 109.50

list

AUTO-TELE-QUINAR

F 3.5, 135 mm

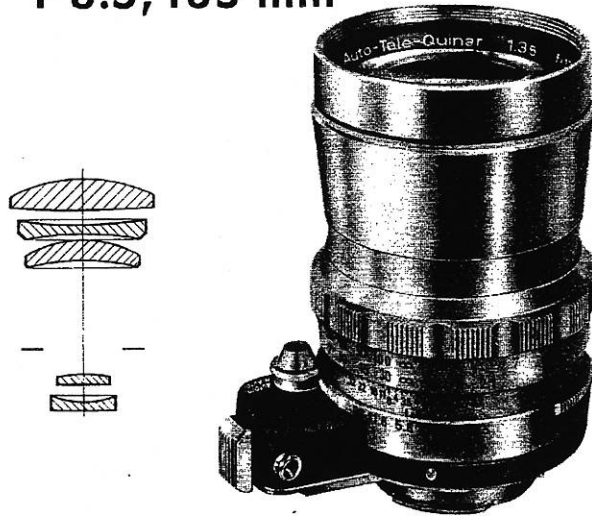

The f/3.5, 135 mm Auto-Tele-Quinar Telephoto lens with instant-reopen automatic diaphragm is a new 5-element objective in a light-weight chrome mount. The lens will give high performance to meet the demanding requirements of the 'perfectionist'. There are 8 diaphragm stops from f/3.5 to f/32. Angle of view is 18°. Lens focuses from infinity to 6 $\frac{1}{2}$ feet, and has dual control for both automatic and manual operation. Leather case and sunshade furnished at no additional charge.

Price
\$ 119.50

list

Filter size series 7

AUTO-QUINAR

F 2.8, 135

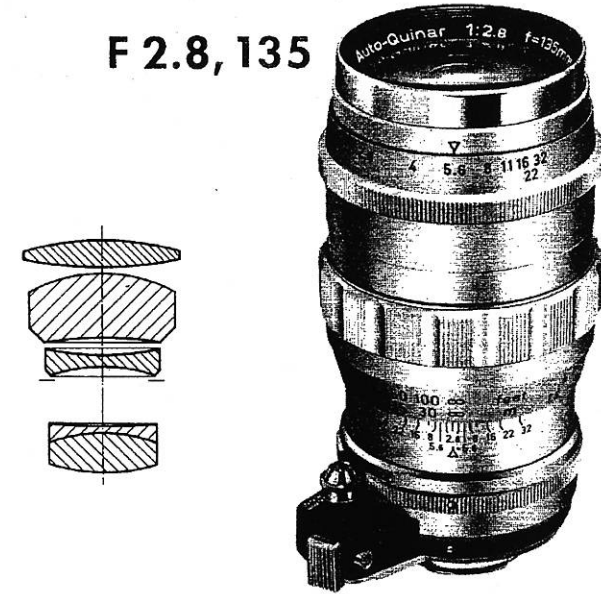

The f/2.8, 135 mm Auto-Quinar Telephoto lens with instant-reopen automatic diaphragm is a fast telephoto lens of superior design. Comprised of a 5-element lens system, this lens meets the highest standards for color, sharpness and performance. There are 8 diaphragm stops from f/2.8 to f/32. Angle of view is 18°. Lens focuses from infinity down to 5 feet, and can be operated both automatically and manually. Leather case and sunshade furnished with lens at no additional charge.

Price
\$ 189.50

list

Filter size series 7

STEINHEIL TELE-QUINAR

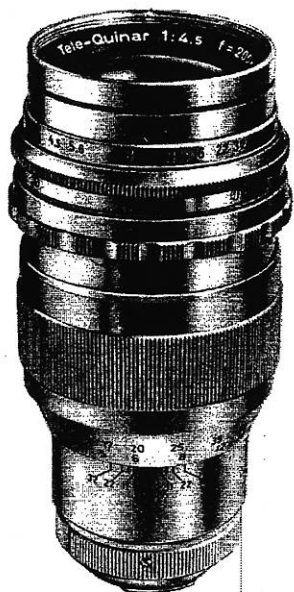

F 4.5, 200 mm

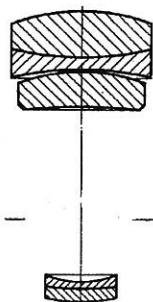

The f/4.5, 200 mm Steinheil Tele-Quinar is a true telephoto lens with preset diaphragm. It has a 5-element lens system and renders a 4-time magnification in comparison to a normal 50 mm. lens. The Tele-Quinar is corrected according to the latest scientific standards, and is highly recommended for color. There are 7 diaphragm stops to f/32; lens focuses down to 7 feet. Angle of view is 12°. Leather case and sunshade are furnished at no additional charge.

Price
\$ 120.00
list

Filter size series 7

STEINHEIL QUINAR



F 2.8, 135 mm

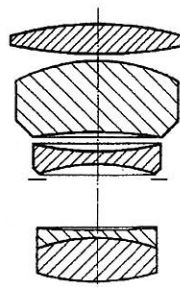

The f/2.8, 135 mm Quinar Telephoto lens has a preset diaphragm. It renders a 2.7 time magnification over a normal lens, and is an ideal lens for sports, bird, nature and candid photography.

The Quinar has a 5-element lens system, and focuses down to 3.3 feet. There are 8 diaphragm stops to f/32. Angle of view is 18°. Leather case and sunshade furnished at no additional charge.

Price
\$ 100.00
list

Filter size series 7

STEINHEIL CULMIGON

F 4.5, 35 mm



Price **\$ 39.50** list
Leather case **\$ 6.95**
Filter size series 5

The f/4.5, 35 mm Culmigon Wide Angle lens has a 64° angle of view. It is recommended for picture taking in narrow areas where it is not possible to move backwards because of restricted space. Highly corrected, and offering excellent detail, the Culmigon will give splendid results with both color and black and white film.

STEINHEIL CASSAR

F 4.5, 105 mm



Price **\$ 31.50** list
Leather case **\$ 5.75**
Filter size series 7

The f/4.5, 105 mm Cassar lens in special short mount is specially designed for use with bellows extensions for close-up work.

The lens fully meets the requirements for sharpness, brilliance and contrast.