

EXAKTA

VX II b

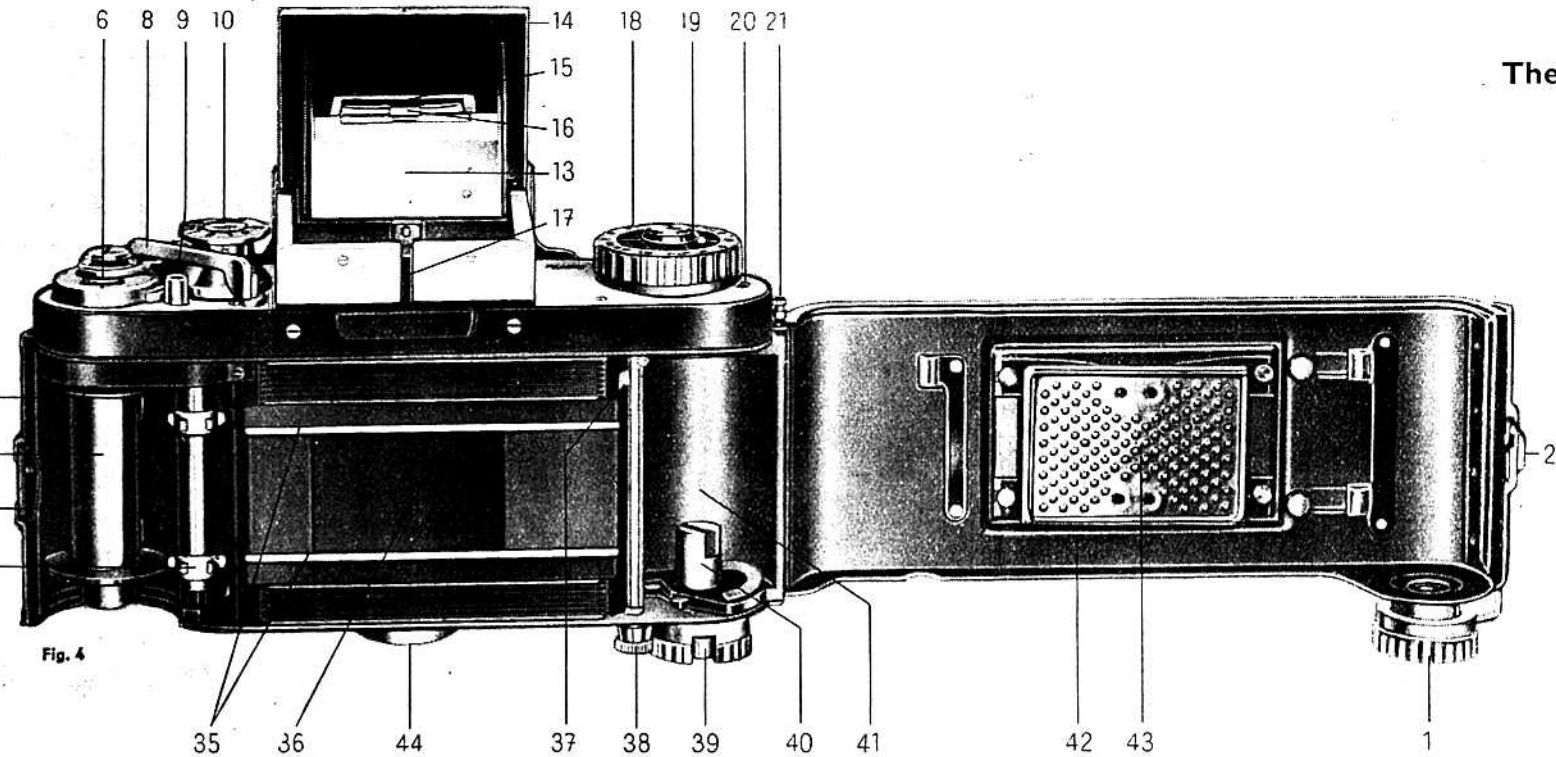

The important operating controls of the EXAKTA VX IIb



- 1 = Knob for opening the camera back
- 2 = Camera-back lock (can be operated only with knob 1)
- 3 = Shutter release knob
- 4 = Pivoted shutter-release lock
- 5 = Eyelets for carrying strap or cord
- 6 = Frame counter
- 7 = Frame-counter setting knob
- 8 = Rapid-wind lever for tensioning shutter and advancing film
- 9 = Rewind declutching button
- 10 = Small shutter-speed setting knob (for speeds from $\frac{1}{30}$ to $\frac{1}{1000}$ sec., T and B)
- 11 = Friction dog of rapid-wind lever

- 12 = Flash contact "X" (primarily for electronic flash units)
- 13 = Hood of Finder Hood
- 14 = Front of Finder Hood
- 15 = Swing-up focusing magnifier
- 16 = Handle for swinging the focusing magnifier
- 17 = Lever for opening the Finder Hood
- 18 = Large shutter-speed setting knob (for speeds from $1/8$ to 12 sec. and also for delayed-action at $1/4$ to 6 sec.)
- 19 = Film-type reminder disc
- 20 = Indicator disc for checking film advance
- 21 = Hinge-pin knob (camera-back hinge)
- 22 = Flash contact "FP" (for flashbulbs)
- 23 = Red aligning dot on camera (for changing lenses)
- 24 = Depth-of-field scale or automatic depth-of-field indicator
- 25 = Distance-setting (focusing) ring
- 26 = Aperture-setting ring
- 27 = Release knob or rocker of lens
- 28 = Lens
- 29 = Red aligning dot on lens (for lens changing)
- 30 = Lens locking lever
- 31 = Flash contact "F" (for flashbulbs)
- 32 = Take-up spool
- 33 = Chamber for take-up spool or cassette
- 34 = Film-wind sprocket
- 35 = Film guide runners
- 36 = Film gate with blind of focal-plane shutter
- 37 = Film cutting knife
- 38 = Knob of film-cutting knife
- 39 = Rewind crank
- 40 = Dog of rewind crank
- 41 = Chamber for cassette containing unexposed film
- 42 = Hinged, detachable camera back
- 43 = Exchangeable film pressure plate
- 44 = Tripod bush
- 45 = Penta Prism
- 46 = Eyepiece of Penta Prism

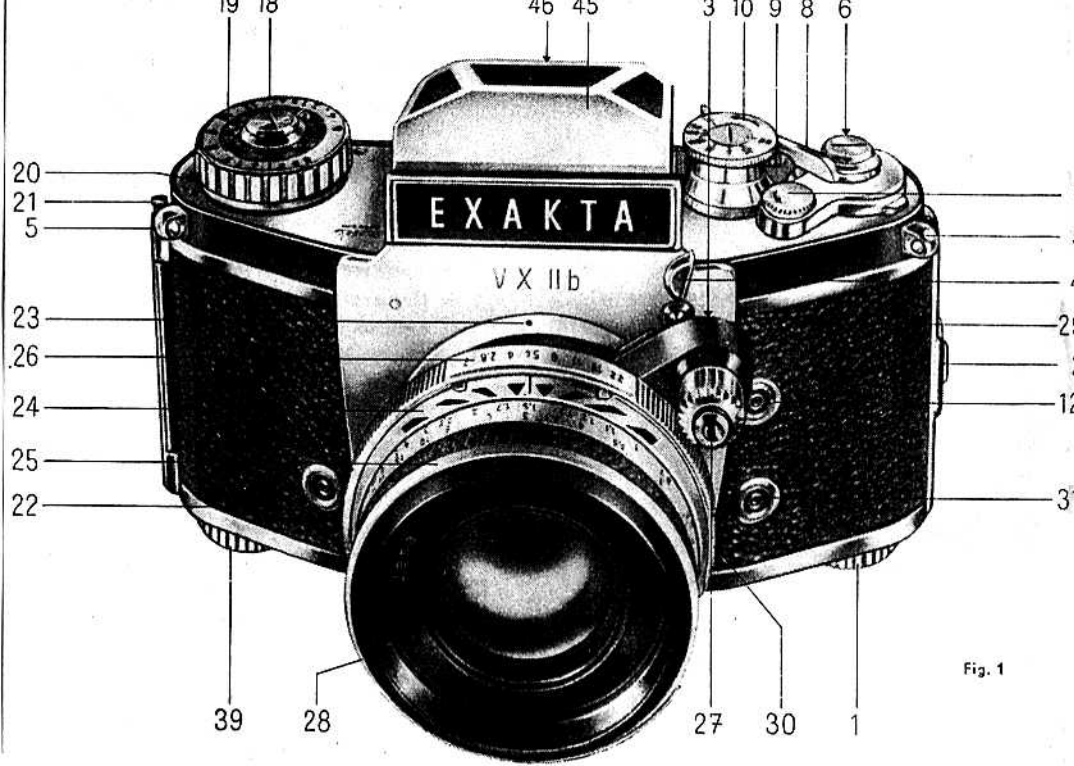

Fig. 1

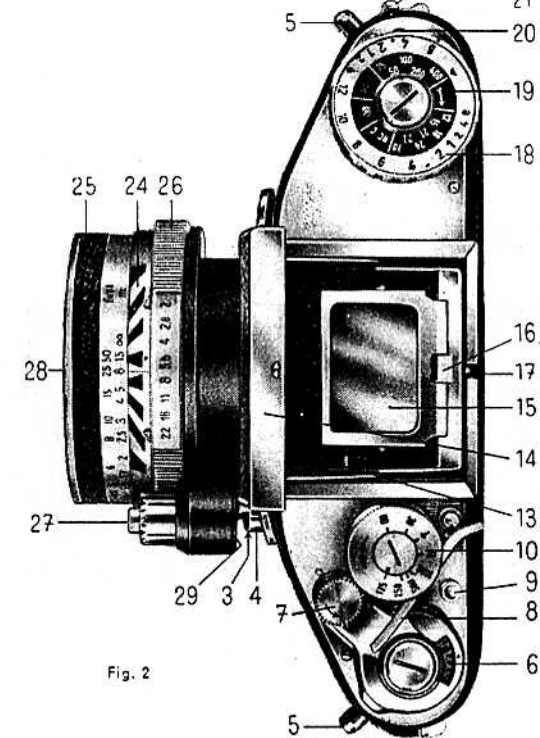

Fig. 2

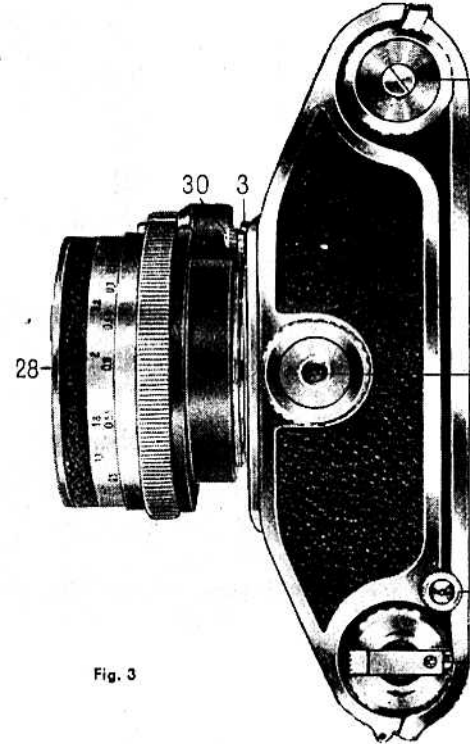

Fig. 3

We are delighted that you have chosen an EXAKTA VX and we wish you every success with your new camera.

We would like to advise you, however, to read this instruction manual carefully before you start using your camera. In this way you will obtain the greatest possible service from it, since you will eliminate from the outset the possibility of operating it incorrectly, and possibly damaging the mechanism. The EXAKTA VX is a high-quality precision instrument which can naturally only be expected to answer all your requirements when it is always handled correctly.

Fold out the opposite page to the left to reveal the itemised guide to the camera controls; in this way you can keep constantly referring to this first illustration whilst you are reading the text.

We recommend you first to get thoroughly familiar with the EXAKTA VX by practising with the camera unloaded before you insert a film. Get used to the operation of the shutter, the technique for opening and closing the camera, selecting the subject and focusing it, with both the Finder Hood and also the Penta

Prism. Handle the camera just as you would if it contained a film. Lastly practice inserting a new film; here it is advisable to get accustomed to the technique by using an old, scrap film. The EXAKTA VX operates on the single-lens reflex principle, which was first introduced into miniature photography by Ihagee. Inside the camera there is a small, pivoted mirror which up to the moment of pressing the release button reflects the image formed by the taking lens on to the focusing screen. Only in this way is it possible to eliminate all parallax between the reflex image and the final picture and so be able to select your subject and focus the image with complete confidence by means of the reflex viewfinder alone.

Keep in touch with your photographic dealer so that he can keep you constantly informed about all the latest developments in our production range. Naturally, we are always ready to give you any advice and information you may need, whenever you require our assistance on particular points regarding the use of the EXAKTA.

IHAGEE KAMERAWERK AG



Opening and closing the camera back

Pull out knob (1) as shown in Fig. 5 turn it either to the right or left to disengage the catch and then swing open the camera back (42). To close the back (42), gently press it shut, then turn the knob (1) either to the right or left until it springs back to its original position. If you wish to detach the back (42) from the camera completely, then open the back and withdraw the hinge pin by means of knob (21). To re-attach the back, hold it in position against the camera and guide the pin back into the hinge.

Opening and closing the Finder Hood

The Finder Hood (13) is opened by pressing on the lever (17). To close the hood, press the front (14) backwards until it locks. The focusing

Fig. 5

magnifier (15) can be swung into either the working or rest position by means of handle (16). For further information on the use of the Finder Hood see page 13. The image will only be visible on the ground-glass focusing screen in the Finder Hood when the shutter is tensioned. See next section for instructions on tensioning the shutter.

Shutter and film advance

These are coupled together, eliminating double exposures and blank frames. Swing the shutter-release lock (4) out of the way, then release the shutter either by pressing directly on the shutter release knob (3) or indirectly by depressing the release knob or rocker arm (27) on the lens.

The shutter is tensioned and the film wound on by operating the rapid-wind lever (8). This lever should always be swung right up to its stop (Fig. 6) and will then spring back of its own accord. It is impossible to release the shutter before it has been tensioned fully and

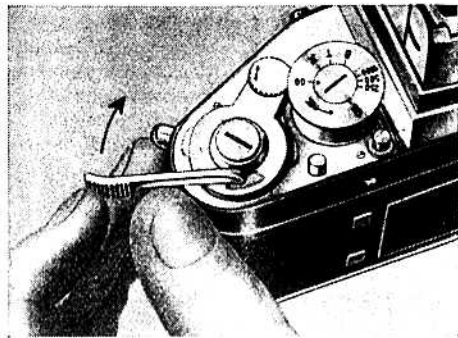

Fig. 6

the film wound on. Neither can the film be wound on until the shutter has been released; it will not be possible to operate the shutter release when the rapid-wind lever (8) is at an intermediate point of its travel. Never force the rapid-wind lever back to its rest position or the mechanism will be damaged. Should the lever not spring back automatically when the

camera is empty, then open the back (42) and turn the film-wind sprocket (34) a little way in the direction of the exposed-film chamber (33); this will cause the rapid-wind lever (8) to spring back. Restrain the lever with your thumb during its return travel.

When you have finished taking pictures, swing the shutter-release lock (4) so that it covers the shutter release knob (3).

Operating the shutter

Shutter speeds from $1/30$ to $1/1000$ sec.: Lift the smaller shutter-speed setting knob (10) — see Fig. 7 —, turn it in the direction of the arrow until the desired speed value is opposite the setting dot on the central disc and then allow the knob (10) to spring back. This operation may be performed either before or after tensioning the shutter.

The figures represent fractions of seconds; for example 30 = $1/30$ sec. Intermediate speeds cannot be set. Exposures from $1/30$ to $1/1000$ sec. can safely be taken with a hand-held camera

i.e. without a tripod. Longer exposures (see next paragraph) should only be taken when the camera is placed on a tripod or other firm support.

Time exposures of any desired length: Set the smaller shutter-speed setting knob (10) to either T or B (either before or after tensioning the shutter). T = the shutter will open when the release knob (3) or the release mechanism on the lens is operated and will close again upon a second pressure. B = the shutter will remain open so long as pressure is maintained upon

Fig. 7

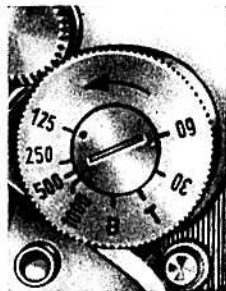
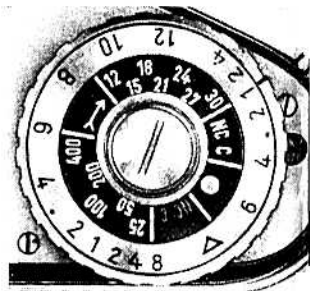

Fig. 8



the shutter release knob (3) or on the release mechanism of the lens. Lenses with fully-automatic diaphragms should be adjusted for normal manual aperture setting; otherwise the diaphragm will open prematurely. When taking time exposures with the f 2.8/50 mm Domiplan lens, use either the B setting and if necessary a cable release with locking device, or the T setting and an additional locking knob for the release rocker. For further details see the sections dealing with the various lenses pages 7...12. The B and T settings are very important for taking night and indoor exposures.

Shutter speeds from $1/8$ to 12 sec.: Tension the shutter. Set the smaller shutter-speed setting knob (10) to T or B. Turn the larger shutter-speed setting knob (18) in a clockwise direction — see Fig. 8 — until it stops; this tensions the speed-regulating mechanism. Then lift the outer ring of the shutter-speed setting knob (18), turn it until the red mark is opposite the desired black speed value and then let the outer ring spring back. The small figures 8, 4 and 2 signify fractions of seconds, e.g. $1/8$, $1/4$ and $1/2$ sec. The larger figures from figure 1 to 12 represent whole seconds.

After a fairly brief exposure (e.g. $1/8$ sec.) has been used, the speed-regulating mechanism will be only slightly run down; despite this, it should always be wound right up by turning the knob as far as it will go. Lenses with fully-automatic diaphragms should be set for normal manual aperture adjustment, to prevent premature opening of the diaphragm. Use an additional release-rocker locking knob with the Domiplan f 2.8/50 mm lens.

Using the self-timer (delayed action release)

(a) At shutter speeds from $1/4$ to 6 sec.: tension the shutter. Set smaller shutter-speed setting knob (10) to T or B. Turn the larger shutter-speed setting knob (18) as far as it will go and select the desired red shutter-speed setting as described above. The small figures 4 and 2 represent fractions of seconds, $1/4$ and $1/2$ sec. respectively. The larger figures from 1 to 6 signify whole seconds (the 3-second setting is represented merely by a dot).

(b) Shutter speeds from $1/30$ to $1/1000$ sec.: tension the shutter. Do not set the smaller shutter-speed setting knob (10) to T or B, but to the desired

shutter speed e.g. $\frac{1}{125}$ sec. Then rotate the large speed setting knob (18) as far as it will go and set it to **any** of the red figures as described above.

The black figures on the larger shutter-speed setting knob (18) indicate "immediate" exposure settings, whereas the red figures represent delayed-action exposures (with which the shutter opens approximately 12 seconds after pressing the release).

Whenever delayed-action exposures are made with lenses which have fully-automatic diaphragms, these should be set for normal manual aperture adjustment in order to prevent the diaphragm from opening prematurely. With the f 2.8/50 mm Domiplan lens an additional locking knob for the release rocker must be employed.

For all shutter speeds of $\frac{1}{8}$ sec. and slower, a tripod should be used or else the camera should be placed on a firm support (table, wall). The camera should also be supported

suitably to eliminate shake when taking delayed-action exposures. The tripod bush (44) is in the base of the EXAKTA VX.

Cable releases (with long plunger) may be screwed into the shutter release knob (3) on the camera or into the release mechanism on the lens. This is particularly important when using shutter speeds of $\frac{1}{8}$ second and slower and virtually indispensable when employing the B setting.

Although unintentional double exposures cannot occur, it is, however, possible to take double exposures on purpose (e.g. for trick photography). After the first exposure, the shutter can be re-tensioned without winding on the film as follows: turn the smaller shutter-speed setting knob (10) as far as it will travel in the direction of the arrow, without lifting it; the knob should be held to prevent it from springing back. The frame counter (6) always indicates the number of exposures and will, therefore, record two exposures for an intentional double exposure.



Fig. 9

Operating the lens

The lens (28) is exchangeable: press the locking lever (3) towards the lens, turn the lens to the left (Fig. 9) until the red aligning dots (23 and 29) are opposite one another and then lift off the lens towards the front. To insert a lens, proceed in the reverse sequence: position the

lens with the red dots in line, then turn the lens to the right until it engages. If, when removing or inserting the fully-automatic Jena lenses, the adjusting screw of the release knob (27) should foul any part of the camera, then the remedy is simply to set the lens to "Automatic" as described on page 10.

Focusing is performed by turning the distance-setting ring (25); where the ring bears two engraved scales, the lower numerical values indicate metres, the larger values feet. The focus definition is checked by observing the ground-glass screen in the Finder Hood or Penta Prism: when the definition of the reflex image appears at its sharpest, then the distance of the focused subject (in feet or metres) will be opposite the red index mark on the scale. This distance is measured from the subject to the camera back.

The aperture is adjusted by means of the aperture-setting ring (26). The numerically-smaller aperture values, e.g. 2.8, 4, represent relatively large lens openings; these permit fast shutter-speeds but give only limited depth of field. The larger aperture values, e.g. 16, 22 conversely

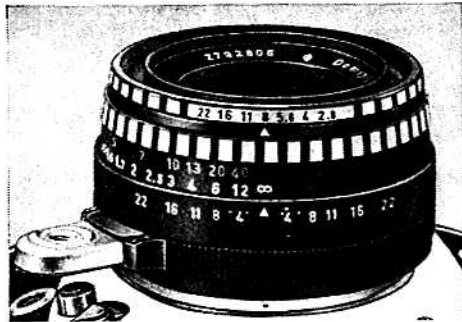

Fig. 10

VX lenses: on either side of the red distance-setting index mark will be found a series of aperture values (f/Nos.). The distance figures on the feet (or metre) scale which are in line with the aperture values corresponding to the lens opening actually used indicate where the depth-of-field "sharp zone" begins and ends. If the aperture figure on one side is opposite the infinity symbol (∞) or even beyond it (reading outwards from the centre), then the depth-of-field zone extends to infinity. The f 2/50 mm Jena Pancolar lens is equipped with automatic depth-of-field indicators.

Two examples

Distance setting ∞ , aperture f 8 = depth of field extends from about 24 ft (7 m) to infinity; see Fig. 10.

Distance setting 8 ft (2.5 m), aperture f 16 = depth of field extends from about 5 ft (1.5 m) to approx. 36 ft (11 m); see Fig. 11.

Use a large lens opening (= lowest aperture value) for focusing in the ground-glass screen in order to obtain a brilliant finder image, and then stop down immediately before taking the

picture. This operation does not involve lowering the camera from the taking position, since the lens is provided with a fully-automatic spring or pressure diaphragm.

The fully-automatic pressure diaphragm of the Domiplan f 2.8/50 mm lens (Fig. 10)

The fully-automatic pressure diaphragm is used at full aperture for focusing and observing. Pre-select the desired smaller diaphragm aperture by turning the diaphragm-setting ring. The appropriate numerically-larger aperture value must be opposite the red triangular mark. It is also possible to set intermediate values between any two f/stop figures. By pressing on the release rocker the lens is stopped down automatically; when the release rocker is released, the diaphragm opens up to the maximum aperture. The rocker should not, however, be released until the shutter has closed (most important when using the slower "instantaneous" shutter speeds). For longer exposures, both when using the large shutter-speed setting knob (18) and when employing the B and T settings on the small speed-setting knob (10), and also for all

delayed-action exposures, either of the following procedures should be adopted:

a) Screw a cable release with a long plunger and time-exposure lock into the release rocker. In this way pressure can be maintained on the release rocker or body shutter release for any desired period without having to keep one's finger constantly on the release (also eliminating camera shake).

b) Alternatively, a special locking knob (available as an accessory) can be screwed into the release rocker; by propping up the lower part of the rocker the automatic diaphragm mechanism will be disengaged. The lens is then stopped down (i.e. a numerically-larger aperture value is selected) by turning the aperture-setting ring. The lens opening will remain stopped down according to the extent to which the ring is rotated.

Operating the fully-automatic spring diaphragm of the Jena T f 2.8/50 mm (Fig. 11) and Jena Pancolar f 2/50 mm lenses (Fig. 12)

Focusing is performed by turning the front, distance-setting ring.



Fig. 11

Set the lens either for fully-automatic spring diaphragm or normal diaphragm setting. When using the fully-automatic spring diaphragm the release knob (27) on the lens must project, together with its mount, by about 1 cm or $\frac{1}{4}$ in. in front of the black housing. If necessary press the mount of the release knob gently in the direction of the camera body and turn it to the right (looking at the camera from the

front); the mount and the release knob will then lock into the "automatic" position. The automatic diaphragm mechanism is disengaged as follows: press the mount of the lens release knob (27) in the direction of the camera and turn it to the left (looking at the camera from the front); when the release knob and its mount have been pressed back into the release-mechanism housing and locked in this position, then the diaphragm can be stopped down (i.e. a numerically-larger f/No. selected) by turning the diaphragm-setting ring (immediately in front of the camera body). The diaphragm will then remain stopped down according to the amount by which the ring is rotated (this is important for time and delayed-action exposures). The diaphragm-setting ring has click stops at all aperture values, including the intermediate values which are not engraved on the scale. The desired aperture value must be set opposite the red mark. In order to ensure that the release button on the camera is always depressed sufficiently, an adjusting screw is provided on the lower side of the lens release plunger so that the latter can be set to the required length by means of

a screwdriver. If this adjusting screw should foul any part of the camera when the lens is being inserted or removed, then the lens need only be re-set to "Automatic". When employing the fully-automatic spring diaphragm, the lens is always used at its full aperture for focusing and observing the reflex finder image. It can then be stopped down to the pre-selected smaller aperture (numerically-larger f/No.) just by pressing the release. This aperture value, at which the exposure is to be made, is selected by means of the diaphragm-setting ring. By pressing the release knob (27) on the lens, first the diaphragm closes down to the pre-selected smaller aperture and then the camera shutter is released. By taking your finger off the lens release knob (27), the diaphragm automatically opens up to its maximum aperture; the knob should, therefore, not be released until the shutter has closed completely (this is particularly important when using the slower instantaneous speed settings). For taking time and delayed-action exposures the lens should be set for normal diaphragm operation; the cable release (with long plunger) can be screwed into the release knob (27) on the lens.

For checking the depth of field during focusing when the lens is set for automatic diaphragm operation, the release knob (27) on the lens should be depressed just far enough to close the diaphragm down to the desired aperture without releasing the shutter. The Jena Pancolar f 2/50 mm lens is provided with an automatic depth-of-field indicator (see Fig. 12). After the aperture and distance settings

Fig. 12

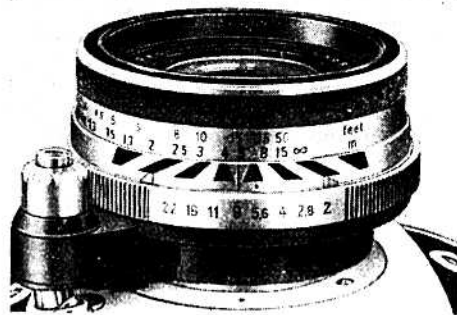

have been adjusted, the two red pointers will indicate the extent of the depth-of-field range. Observe the positions of the red indicators and note whether they are in the centre of the alternate black and white guide bands or at the division between two bands. Then follow the appropriate band until it meets the distance scale; the distance figure on the left will show where the depth of field begins whilst the figure on the right shows where the zone ends. Practice this operation by setting your own lens as follows: aperture f 8 distance 5 metres (approx. 15 ft) = depth-of-field range extends from less than 3 metres (approx. 9 ft) to over 15 metres (actually 23 metres or 76 feet).

Focusing when using infra-red film

When using infra-red-sensitive film, first focus the image on the ground-glass screen. Then note the indicated subject distance (in metres or feet, or infinity) and rotate the distance-setting ring so as to move the subject-distance figure from the normal red index mark to the red dot either to the right or to the left of it.

Using the Finder Hood

Upon looking into the Finder Hood (13) of the EXAKTA VX you will see a brilliant, upright and enlarged image on the ground-glass screen. This image can be used both for selecting and framing the subject and also for focusing and checking the depth of field by provisionally stopping down the lens. The magnifying ground-glass screen fitted in the Finder Hood will generally give a large enough image for normal viewfinding purposes, but for accurate focusing it is advisable to employ the additional focusing magnifier. The pivoted focusing magnifier (15) will spring into its working position when the Finder Hood is opened, but can be folded back out of the way by operating handle (16); see also page 2.

Normally, the EXAKTA VX is held at chest or shoulder level (Fig. 13). The method of



Fig. 13



Fig. 14



Fig. 15



Fig. 16

holding the camera when using the supplementary focusing magnifier is shown in Figs. 14 and 15. When taking vertical pictures with the Finder Hood it is possible to shoot at right angles (Fig. 15). This is particularly useful for working inconspicuously since the photographer can

remain in concealment (Fig. 16). The Penta Prism (see next section) makes it possible to take vertical pictures with a direct line of vision and also provides a laterally-correct and upright viewfinder image. The image on the ground-glass screen of the Finder Hood (13)



can also be observed from below when the camera is held above the head. This will prove very useful when taking pictures over walls or the heads of a crowd.

The EXAKTA VX is a multiple-system camera: the Finder Hood can be detached, allowing the Penta Prism (45) to be fitted when required — as explained above. There is also the Lens Magnifier for close-up photography and photomicrography and the "Stereoflex" Stereo View Finder for 3-dimensional photography; see pages 33 and 35. When exchanging viewfinder units, the Finder Hood (13) must first be closed. Lift off the Finder Hood by pulling it smoothly upwards (Fig. 17). When re-inserting the Finder Hood, it must be introduced so that it is exactly vertical and then pushed down until it locks; never employ force.

Users who normally wear glasses should use their close-up (reading) spectacles for focusing with the Finder Hood.

Fig. 17

Using the Penta Prism

The Penta Prism (45) (see Fig. 1), is the other principal focusing system of the EXAKTA VX and is primarily intended for taking pictures of moving subjects such as sporting events (for which it is virtually indispensable).

The Penta Prism (45) is inserted into the camera and removed in exactly the same way as the Finder Hood. The camera is always held at eye level when using the Penta Prism; the eyepiece (46) can be put to either the left or the right eye. The reflex image on the ground-glass screen will invariably be upright and laterally-correct no matter whether the camera is held horizontally or vertically; this is particularly useful when taking pictures of moving subjects since the image in the viewfinder will move in the same direction as the subject itself. With very rapidly-moving subjects the camera can thus be "panned" by swinging it gently in the direction of motion of the subject (as for example, with racing cars).

For normal horizontal and vertical pictures the EXAKTA VX when fitted with the Penta Prism (45) is preferably held in the left hand,



Fig. 18



Fig. 19

using the right thumb and forefinger for focusing. Additional support can be given with the left hand, employing the left forefinger for releasing the shutter (Figs. 18 and 19). For taking horizontal pictures the camera can also be used upside down: press the back of the EXAKTA VX against your forehead to prevent camera shake. Photographers who normally

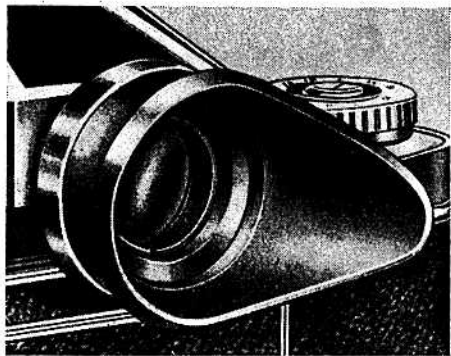

Fig. 20

wear spectacles should use their distance glasses for focusing with the Penta Prism.

An invaluable accessory for use with the Penta Prism is the flexible eyepiece cup (Fig. 20): this is fitted on to the eyepiece (46) of the Penta Prism and shields it from distracting straylight. It is also helpful for spectacle-wearers since

vision-correction lenses made by one's optician can be inserted into the mount, making it possible to focus without wearing glasses.

Exchanging the Ground-Glass Screen and the use of the Distance Meter or Fresnel Lens

The magnifying ground-glass screens for the EXAKTA VX viewfinder units are interchangeable. Before removing the screen from the Finder Hood, the hood must be closed.

To remove the viewfinder unit from the camera, grasp the ground-glass screen by the longer sides and lift it out of the viewfinder. When inserting the ground-glass screen, it should once again always be grasped by the long sides (never touch the matted surface) and pushed home between the retaining springs in the viewfinder. When inserting the screen into the Finder Hood, first close the hood.

Instead of the ground-glass magnifying screen, the Distance Meter (rangefinder) or Fresnel

Lens screens can also be used in the Finder Hood, Penta Prism and Lens Magnifier. Both of these screens contain a split-image rangefinder in the centre of the image field, which doubles the accuracy of focusing; they are, therefore, particularly useful for persons with defective vision and for taking pictures under unfavourable lighting conditions. When the lens is focused correctly the two half-images in the circular rangefinder field must be aligned accurately, without any displacement, either

Fig. 21



above and below or alongside each other (Fig. 21). Do not use a smaller aperture than $f\ 5.6$ for focusing, or otherwise one half of the rangefinder field will appear dark.

The eye used for viewing must be positioned exactly in the centre of the viewfinder eyepiece when using the Penta Prism, and directly over the centre of the magnifying lens when using the Finder Hood or Lens Magnifier; an oblique angle of view will result in incorrect focusing and unsharp pictures.



Fig. 22

Loading the film

Use perforated miniature film 35 mm in width. 1.6 metres (5 ft 4 in) of film gives 36 exposures, 24 mm x 36 mm in size. To ensure trouble-free film transport it is essential to use only faultless film cassettes. When using film from daylight-

loading spools, these should only be inserted in cassettes made by the same manufacturers. Remove the camera back in the manner already described, and pull out the rewind crank (39) by means of its knob. Place the cassette containing the unexposed film in the chamber (41), swing out the rewind crank (39) and push it back into the camera body by depressing the knob; whilst doing so twist the knob gently in the direction of the arrow so as to make the dog (40) engage with the bar in the cassette core. Then guide the film over the film guide runners (35) towards the take-up spool (32); the emulsion side of the film must face the lens. It is advisable to lay the camera down if possible whilst securing the end of the film; as shown in Fig. 22, the take-up spool (32) can be removed from the friction dog (11) of the rapid-wind lever (8). Push the beginning of the film under the clamping spring of the take-up spool (32) and then wrap one-half turn round the core of the spool. Replace the take-up spool (32) in the film chamber (33) and turn it slightly in the wind-on direction so that the friction dog (11) of the rapid-wind lever couples with the bar

inside the spool core and allows the spool to be pushed right home into the chamber (33). If you leave the take-up spool (32) in the camera whilst attaching the beginning of the film, then turn it so that the clamping spring is facing upwards.

Now swing the rapid-wind lever (8) right up to its stop (if necessary first releasing the shutter) so that the film is pulled as tightly as possible from the feed cassette, over the film

Fig. 23

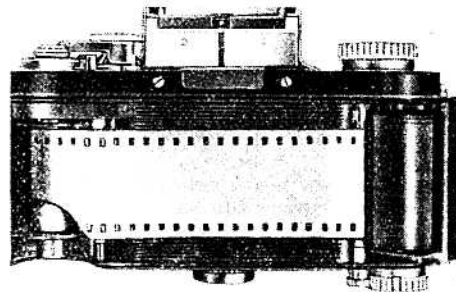

guide runners (35), thence over the film wind sprocket (34) and on to the take-up spool (32). The teeth of the film-wind sprocket (34) must engage with the perforation holes on both sides of the film (Fig. 23).

Close the camera back, and now expose two blank frames to wind on the fogged leader-length at the beginning of the film: swing the rapid-wind lever (8) as far as it will go (if necessary first releasing the shutter), allow it to

Fig. 24

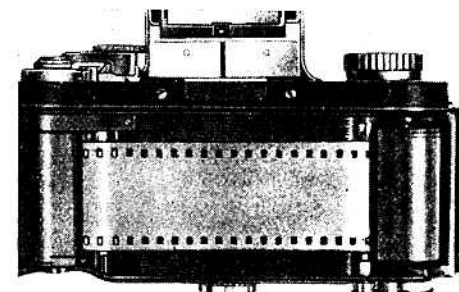

spring back, then press the shutter release (to take the first blank frame); follow this by swinging the rapid-wind lever (8) up to its stop once again, allow it to return and then press the release once again to take the second blank frame. Finally swing the rapid-wind lever (8) as far as it will go for a third time and let it spring back: an unexposed frame will then be positioned in the film gate (36). In conclusion, set the frame counter (6) by turning the setting

Fig. 25

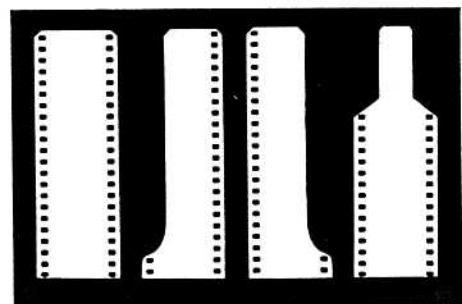

knob (7) in the direction of the arrow with your index finger until the stroke-mark immediately before "Fig. 1" is in line with the index mark. (The counter operates **after** each exposure.)

The camera is now ready for action.

In place of the fake-up spool (32) an empty standard-type film cassette may be placed in the take-up chamber. Take care to check the condition of this take-up cassette thoroughly: the core should move easily within the shell of the cassette and must not jam (if necessary the friction points of the cassette core may be lubricated by rubbing them with paraffin wax).

When using a take-up cassette proceed as follows: attach the leader tongue of the film to the core of the cassette spool, and insert the cassette so that the friction dog (11) of the rapid-wind lever (8) engages with the bar in the core of the spool. Then check that the film is pulled taut between the two cassettes and is wound up with its emulsion side inwards (Fig. 24).

It is not necessary to trim the beginning of the film specially. Any shape of leader can be used with the take-up spool of the EXAKTA VX, either the narrow tongue provided on standard

commercial cassettes, or, even better, a straight cut-across end as obtained when cutting lengths of film from bulk rolls. When employing a take-up cassette the film must be trimmed to suit the core of the cassette spool; for various trimming patterns see Fig. 25.

In order to check that the film is being advanced correctly, observe the indicator disc (20): the disc with its red mark will rotate when the spool of the feed cassette is turning. Immediately after loading the film, set the film-type reminder disc (19) so that you do not forget what type of film is in the camera (Fig. 26). Turn the reminder disc in the direction of the arrow until the appropriate reference is opposite the black triangular mark on the shutter-speed setting knob (18). Use the figures from 12 to 30 for black-and-white films rated in DIN values, the figures from 25 to 400 for black-and-white ASA ratings, the black letters for daylight-type colour films (C = reversal film, NC for negative films) and the red letters for artificial-light colour films (as before, C = reversal, NC = negative). The example shown in Fig. 26 illustrates the correct setting for a negative colour film intended for use by artificial light.

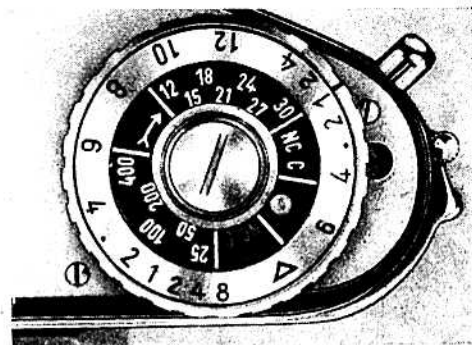
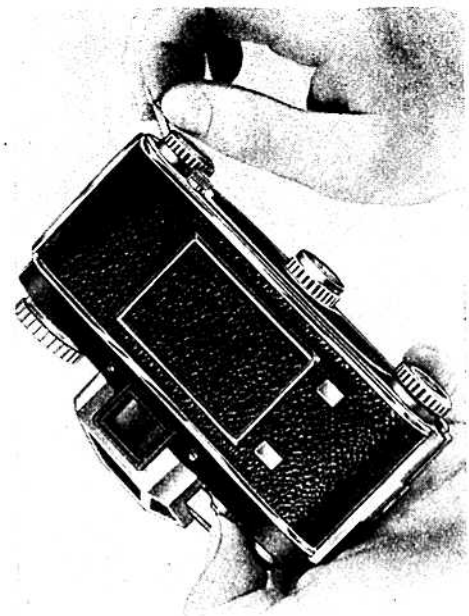

Fig. 26

Changing the film

After taking the 36th exposure it may be possible to take one or two more pictures before the film cannot be advanced any further. Whilst advancing the last frame it may happen that the rapid-wind lever (8) will stop part way through its travel; in this event press the rewind declutching button (9) and the rapid-wind lever



(8) can then be swung right up to its end-stop. The rapid-wind lever will then spring back to its rest position. When the take-up spool (32) is being employed, the film must now be rewound: hold the camera with the left hand and maintain a constant pressure on the rewind declutching button (9). Swing out the rewind crank (39) and with the right hand turn it in the direction of the arrow at a uniform and not excessively-fast speed (Fig. 27). If the film is rewound too quickly, there will be a danger of electrostatic charging which may cause the appearance of dark jagged or branching lines on the negatives. It is possible to see whether the film is being wound back correctly by observing whether the indicator disc (20) and the screwdriver-slotted spindle of the rapid-wind lever (8) are rotating.

When the film is rewound this spindle will stop turning. As soon as the rewind declutching button (9) is released it will spring back into its original position of its own accord. The camera is then set for advancing the next film.

Now open the camera back, pull out the rewind crank (39) by means of its knob (Fig. 28), and

Fig. 27

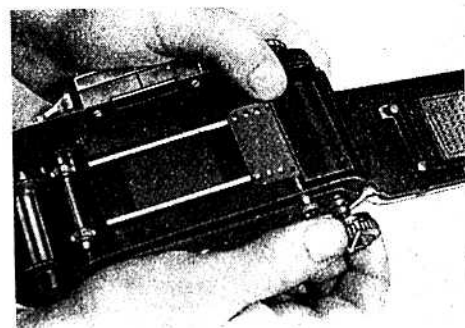

Fig. 28

remove the cassette containing the rewind film from the camera. Depress the knob on the rewind crank (39) once again to push it back. When using an empty cassette in place of the take-up spool, it is not necessary to rewind the film. As soon as the end of the film is reached (when the rapid-wind lever (8) cannot be operated), cut off the film on the feed side of the film gate (36) with the built-in film cutting knife (37). This is done by unscrewing the knob (38)

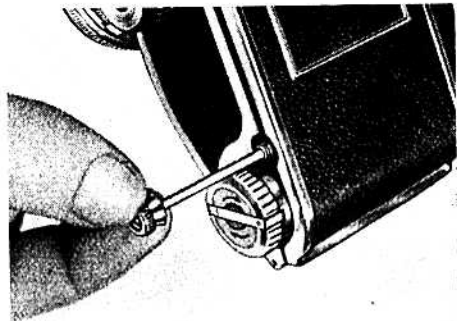

Fig. 29

and withdrawing it by about $1\frac{3}{4}$ inches from the camera body (see Fig. 29); then push knob (38) home once again and screw it up tightly. By operating the rapid-wind lever and releasing the shutter twice in succession, the end of the film can be wound right inside the take-up cassette. The film cutting knife (37) should also be employed in the manner described whenever it is desired to remove a take-up spool containing a partially exposed film from the camera.

Taking flash pictures

The EXAKTA VX IIb has three synchro contacts for connecting flashlight units: an X contact (12) for taking open-flash pictures with electronic flash tubes and flashbulbs, and the FP (22) and F (31) contacts for using expendable flashbulbs in conjunction with the faster shutter speeds. The FP and F contacts take into account the definite pre-ignition delay encountered with the various types of flashbulbs. Further details of the shutter-speed settings required will be found in the following table. The synchro-cable of standard flashguns or electronic flash units should be inserted into the appropriate socket on the camera as indicated in the table. It is advisable to tension the shutter before plugging in the flash unit. Fig. 30 shows the EXAKTA VX with an electronic flash unit. If a flashbulb should fail to fire, i.e. through poor contact in the bulb holder, then the bulb should be removed **after** the shutter has run off. Never insert a new bulb until the shutter has been retensioned.

When using electronic flash units, the synchro-cable should be connected to the X

contact (12) and the shutter set to $\frac{1}{60}$ sec. or a slower speed. When using electronic flash units without storage condensers, designed for mains operation only, the shutter must be set to $\frac{1}{8}$ sec.

Tables for connecting flash units to the three flash synchro-contacts of the EXAKTA VX IIb

- a) Full synchronization:
Connect cable to FP contact (22)

Shutter-speed setting = effective exposure time	Philips Photoflux flashbulbs	
	PF 24	PF 45
	Guide numbers for 40 ASA film (for distances in feet)	
$\frac{1}{1000}$ sec.	24	30
$\frac{1}{500}$ sec.	34	40
$\frac{1}{250}$ sec.	46	60
$\frac{1}{125}$ sec.	58	85
$\frac{1}{60}$ sec.	—	116

- b) Open-flash technique: Connect cable to F contact (31) and set shutter to $\frac{1}{30}$ sec. Can be employed with small, fast-burning flashbulbs.

Shutter-speed setting (not exposure time)	Osram (G. E.) Vacublitz flashbulbs			Philips Photoflux flashbulbs		
	Type	Guide No. (ft) for 40 ASA	Flash duration (\approx exposure time)	Type	Guide No. (ft) for 40 ASA	Flash duration (\approx exposure time)
$\frac{1}{30}$ sec.	XM 1	100	$\frac{1}{100}$ sec.	PF 1	100	$\frac{1}{100}$ sec.
	XM 5	166	$\frac{1}{80}$ sec.	PF 5	166	$\frac{1}{80}$ sec.

- c) Open-flash technique: Connect cable to X contact (12) and shutter to $\frac{1}{8}$ sec. or slower speed. Can be used with all types of flashbulbs: the following data applies to bulbs available in Europe.

Shutter-speed setting (not exposure time)	Osram (G. E.) Vacublitz flashbulbs			Philips Photoflux flashbulbs		
	Type	Guide No. (ft) for 40 ASA	Flash duration (\approx exposure time)	Type	Guide No. (ft) for 40 ASA	Flash duration (\approx exposure time)
$\frac{1}{8}$ sec. or slower	XM 1	100	$\frac{1}{100}$ sec.	PF 1	100	$\frac{1}{100}$ sec.
	XM 5	166	$\frac{1}{80}$ sec.	PF 5	166	$\frac{1}{80}$ sec.
				PF 24	110	$\frac{1}{40}$ sec.
				PF 45	140	$\frac{1}{33}$ sec.
				PF 60	300	$\frac{1}{50}$ sec.
				PF 100	384	$\frac{1}{45}$ sec.

The guide numbers quoted apply only for black-and-white films.

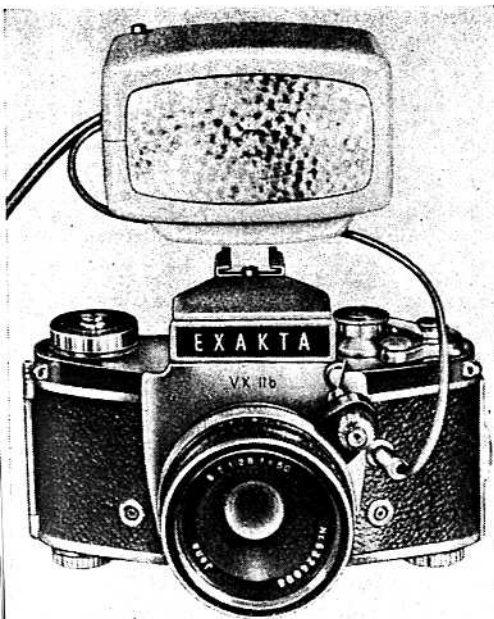

Care of the camera and lenses

Always keep the camera in its ever-ready case with the lens (or lens cap) and viewfinder unit in position; alternatively it may be kept wrapped in a fluff-free cloth. All parts which are easily accessible from the outside should be kept clean and dusted with a soft brush. This applies particularly to the film guide runners (35), the film-wind sprocket (34), the film chambers (33 and 41) and also the camera back (42) including the pressure plate (43). The reflex mirror should only be dusted when absolutely necessary, using a clean soft brush without applying any pressure; do not allow the brush to touch the lightly-greased metal surround of the mirror. Protect the camera against moisture, dust, wind-borne sand, etc. Never touch the glass surfaces of the lenses, the focusing magnifier or the eyepiece of the Penta Prism or the mirror with the fingers. These glass surfaces should be cleaned when necessary only with an extremely soft piece of wash-leather or a soft, fluff-free linen cloth. It

Fig. 30

is highly inadvisable to attempt to interfere with the mechanism of the camera; repairs should be undertaken only by authorized servicing agencies.

Accessories

Accessories increase the versatility of the EXAKTA VX and are absolutely indispensable for many types of work.

Leather Ever-Ready Case (Fig. 31)

This ensures complete protection for the camera whilst it is stored away or being carried, without affecting its readiness for immediate use. The tripod screw enables the camera to be mounted on a tripod whilst in its case.

Lens Hood (Fig. 31)

Indispensable for protecting the lens against side light and also often against light shining straight into the lens, particularly when taking colour pictures. It also serves to keep raindrops and snowflakes off the surface of the lenses.

Fig. 31

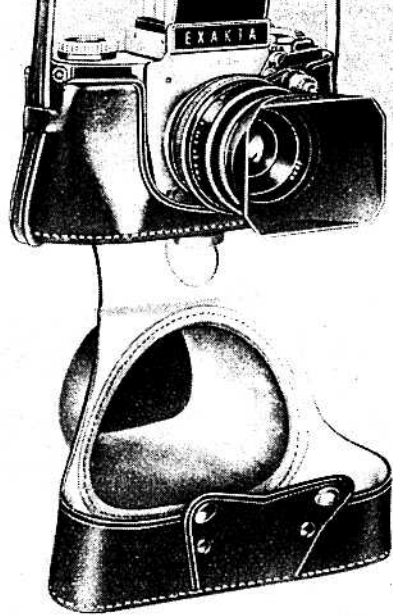

The Ihagee Lens Hoods are of the latest rectangular design, providing a highly efficient shielding effect and are available with

- M 35.5×0.5 mm thread
(37 mm push-on mount diameter),
- M 40.5×0.5 mm thread
(42 mm push-on diameter) and
- M 49×0.75 mm thread
(51 mm push-on diameter).

Giant Release Button

This increases the contact area of the camera release button, so that it can be operated easily even with fingers stiffened by cold or when wearing gloves. It is invaluable for use in winter. (When using lenses fitted with a large release knob or release rocker of their own, these practical devices make it unnecessary to use the Giant Release Button.)

Accessory Shoe (Fig. 30)

The Accessory Shoe is fitted over the Penta Prism eyepiece of the EXAKTA VX and makes it possible to fit accessories, such as a flash unit, exposure meter, etc., on to the camera.

Polarizing Filter

A special filter for eliminating reflections from non-metallic surfaces such as glass, water, varnish, etc. The filter is supplied in a screw-in mount for the EXAKTA VX lenses. The polarizing filter will only be effective when the photograph is taken at an acute angle to the reflecting surface (with glass, at approximately 35°). The filter must be rotated in front of the lens until a position is found in which the reflection is eliminated; its effect can be observed in the reflex image. (The exposure must be increased by 2—3 times.)

Special-purpose Lenses

Fully-comprehensive photography is scarcely possible without special types of lenses, but only the single-lens reflex camera makes it possible to exploit fully all their potentialities in such a simple manner. The reflex viewfinder image of the EXAKTA VX always shows the exact area covered by the lens as well as the image definition and depth of field.

Wide-angle lenses (with a short focal length) embrace a wide angle of view, allowing you to get plenty into your picture although every-

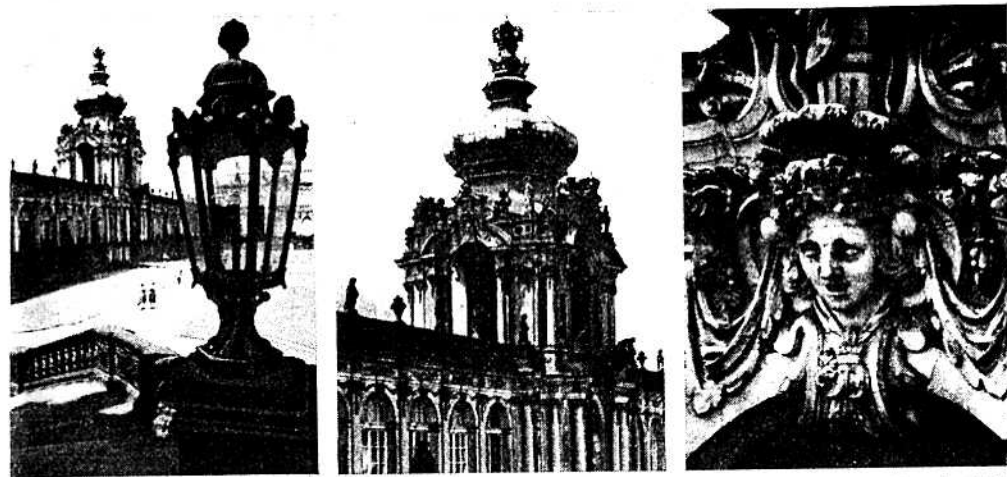

20 mm focal length, 93° angle of field
Fig. 32

50 mm focal length, 45° angle of field

1000 mm focal length, 2.5° angle of field

thing appears relatively small (Fig. 32). They are invaluable for indoor pictures, architectural work, broad landscape scenes, copying pictures in art galleries, etc.

Long-focus lenses include both those of normal construction and also true telephoto lenses; they have a long focal length and make distant objects appear nearer, they, therefore, record



Fig. 33

a relatively narrow section of the subject on a larger scale (Fig. 32). They also tend to reduce the effects of perspective. These lenses are frequently used for taking portraits, in child photography, for photographing sporting events, wild animals and also for landscape

work and many other types of photography. Fig. 33 shows the EXAKTA VX fitted with the popular Jena S f 4/135 mm lens with fully-automatic pressure diaphragm.

If an ultra-high-speed lens is required, the Jena B f 1.5/75 mm lens is also obtainable.

The standard lens is removed in the manner already described and the special-purpose lens fitted in its place. For certain lenses of very long focal length the outer bayonet of the EXAKTA VX is employed. The distance-setting scales of these special lenses are also graduated to indicate the distance from the camera back to the subject.

Bayonet Adapter Rings and Extension Tubes

The single-lens reflex camera comes into its own when taking close-up pictures, since in this field, too, the reflex image always shows the exact area covered by the lens.

The Bayonet Adapter Rings and Extension Tubes may be fitted in any desired combination between the camera and the lens (Fig. 34) and enable the lens to be focused down to the very shortest distances.

The following equipment is available: a Two-in-One Ring providing 5 mm extension increase, and a set of Bayonet Rings and Extension Tubes (the two bayonet adapter rings provide 10 mm extension and the tubes an additional 5, 15 and 30 mm).

Miniature Bellows Attachment

This easy-to-carry unit (Fig. 35) is strongly recommended whenever a large amount of close-up work is to be undertaken, since it provides a quick method of adjusting the image scale continuously. The extension of the bellows can be set to any distance between 35 and 125 mm. This device is primarily intended for taking hand-held close-up pictures, but can be fitted to any tripod and also to the Ihagee Copying Stand. The camera bearer of this device allows the camera to be positioned for both horizontal and vertical pictures.

Autocouple Extension Release

In order to be able to use the latest lenses with fully-automatic spring or pressure diaphragms even when taking close-up pictures with Bayonet Rings and Extension Tubes or with the



Fig. 34

Miniature Bellows Attachment, the extension release should be fitted between the lens and the camera (Figs. 34 and 35).

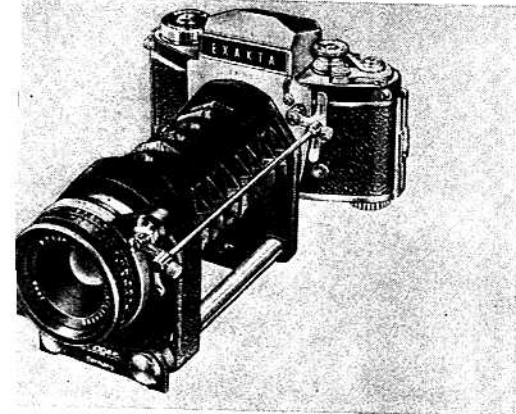

Fig. 35

Ihagee Vielzweck ("multi-purpose") Equipment

This universal equipment designed on the "add-on" principle has been devised to facilitate the most economical employment of the EXAKTA

VX in the widest possible variety of specialized fields. The individual components of the "Vielzweck" Equipment can be used both singly and in combination with one another, and it is possible to build up the equipment piece by piece. The following units are available:

The Swing Angle Attachment with focusing slide for convenient close-up focusing when using the Bayonet Adapter Rings and Extension Tubes.

The large Bellows Attachment, for the most efficient production of close-up pictures, particularly at extremely short subject distances. The bellows extension is continuously adjustable from 35 to 220 mm, making it possible to obtain all scales of reproduction available within this range.

The Transparency Copying Equipment for use with the large Bellows Attachment is employed for making optical duplicates of transparencies.

The Copying Stand and Repro Unit (Fig. 36), obtainable if desired with their own Lighting Equipment, are designed specially for undertaking copying work, but are also suitable for

use as table stands for other types of close-up photography. With the addition of special accessories, the Repro Unit may also be employed for photomicrography.

Microscope Attachment

The Microscope Attachment is designed for connecting the EXAKTA VX to a microscope and makes it possible to use this camera for photomicrographic work with the greatest convenience. The attachment is provided with a quick-change mount and allows the camera to be removed from the microscope with a single operation whenever photographic recording is interrupted. Even when taking pictures through a microscope the image can be focused on the ground-glass screen.

Lens Magnifier

For close-up work and photomicrography a special focusing system is generally employed, the Lens Magnifier. The actual magnifier is provided by any of the highly-corrected standard or special-purpose EXAKTA VX lenses.

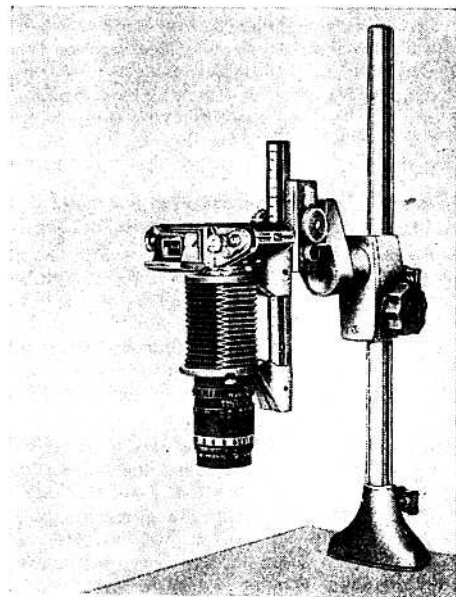

Fig. 36

This gives an enlarged, uniformly sharp and virtually distortion-free reflex image. If no suitable lens is available or can be spared for this purpose when undertaking close-up photography, then an excellently corrected Top Lens is available for use in conjunction with the Lens Magnifier.

Special focusing screens for extreme close-up pictures and photomicrography

In extreme close-up work and when using a microscope, focusing upon the finest details of the subject is often hindered by the grain of the ground-glass screen. To overcome this it is possible to obtain focusing screens with a clear centre spot (3 or 10 mm in diameter) as well as completely clear, unground lenses.

Focusing is then performed by means of the brilliant aerial image, assisted by a hairline cross. These focusing screens are standardized to fit all the three principal focusing units of the EXAKTA VX (with the exception of the Finder Hood for earlier VX models). The method of exchanging the screen has already been described (see page 16). Various other special types of screens can be supplied if re-

quired, e.g. with engraved graticules, centimetre or millimetre divisions, etc.

The Ihagee Macro-Micro Photometer

This device makes it very much easier to determine the correct exposure when taking close-ups and photomicrographs, and also in the optical copying of transparencies. A selenium barrier-layer cell is placed directly within the light-path through the lens and so measures the effective illumination actually entering the camera. The Photometer is used in conjunction with a standard micro-ammeter or luminous-spot galvanometer (effective measuring range 5...30 μ A, internal resistance 1000...5000 ohms).

Ihagee RB 1 Ring-Flash Unit

The Ihagee RB 1 Ring-Flash Unit is a highly up-to-date universal light source for close-up photography. It provides constantly uniform frontal illumination and can be used to overcome the trickiest lighting problems. It can also be employed together with the various lens-extension devices for the EXAKTA VX. The Ihagee Kolpofot consists of an RB 1 Ring

Flash Unit combined with the Bellows Attachment and an f 4/135 mm Jena S lens (which can be stopped right down to f 45). This assembly has been of immense value in medical photography, ensuring needle-sharp pictures both of body cavities (vagina, mouth and pharynx), as well as of the skin, eyes and ears.

The Ihagee Endoscope Adapter

The Endoscope Adapter makes it possible to take pictures inside bodily organs (such as the bladder) by forming a connection between the camera and the viewing instrument or endoscope proper. An "Overrunning Switch Apparatus" is available to conserve the life of the lamp used for illuminating the subject in endoscopic examinations.

Stereo Attachments and Stereo View Finder (Fig. 37)

These are designed for taking three-dimensional photographs. The large Stereo Attachment (65 mm interpupillary base) is for taking pictures of subjects at distances from ∞ (infinity) down to 2 metres (6½ ft), whilst the small

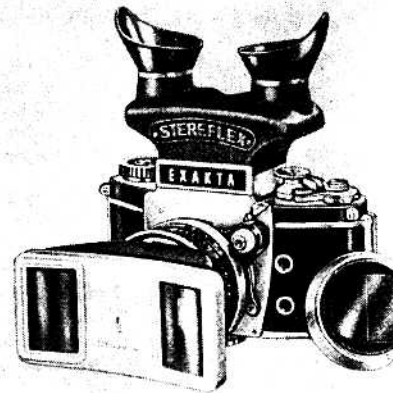

Fig. 37

Stereo Attachment is for use with subjects at distances between 2 metres and 0.15 metres (6 ft to 6 in) (three supplementary lenses are available for focusing at close distances with

the small Stereo Attachment). Both the Stereo Attachments are computed for use only with standard 50 mm lenses, and can be screwed into their front mounts; suitable lenses, include the Jena T f 2.8/50 mm and Pancolar f 2/50 mm with fully-automatic spring diaphragms. With the aid of an adapter ring, these attachments can also be used on other lenses of the same focal length and with similar mounts. After screwing it into place, rotate the Stereo Attachment or its inner section until the dividing line running through the middle of the ground-glass screen is exactly vertical, i.e. parallel to the longer sides of the two half-images, which should already be visible on the focusing screen. This vertical adjustment can be simplified by checking that a selected point in each of the two half-images is at an identical distance from the lower edge of the image frame. The large Stereo Attachment can then be locked by turning the knurled locking ring in the opposite direction. Focusing is performed by means of the reflex image in the usual manner. When using the Stereo Attachment the normal ex-

posure should be increased by 1.5 times (with landscapes and similar subjects) to 1.8 times (for indoor pictures). It is, therefore, necessary to re-set the lens in order to increase the lens opening by an appropriate amount. Since the two half-images must always be positioned alongside one another, the EXAKTA VX must always be held horizontally; consequently the stereo pictures will always be vertical in format. In order to assess the effect of a three-dimensional picture before releasing the shutter, it is possible to fit the fourth viewfinder system of the EXAKTA VX, the "Stereoflex" Stereo View Finder. This will provide a stereoscopic effect in the actual viewfinder image. The Stereflex can also be employed as a simple stereo slide-viewer; for this purpose the ground-glass screen must be removed from the Stereo View Finder by gripping the longer sides of the screen and withdrawing it from the retaining springs. The clip-on frame supplied is then fitted on the View Finder, ensuring that the small locating pins engage with the slots in the retaining springs.

If you would like any further information, we will gladly send you any special leaflets free of charge; please write to let us know the type of work you are interested in.

We would also refer you to the following textbooks:

"35 mm Photography with an EXAKTA" by K. L. Allinson (Fountain Press, London).
"EXAKTA Manual" by Werner Wurst (Fountain Press, London).
Please ask your photo dealer or book store.

There may be certain slight differences between the appearance of the camera and its equipment, and the illustrations in this booklet.

I H A G E E K A M E R A W E R K A G · D R E S D E N A 1 6

Form 846/5/6501 Made in Germany

III-6-15 2248-64 Ag 91-70-004-65 **A**