

PATENT SPECIFICATION



Application Date : Nov. 19, 1920. No. 32,739 / 20.

180,350

Complete Accepted : May 19, 1922.

COMPLETE SPECIFICATION.

Mirror Reflex Camera.

I, JOHAN STEENBERGEN, of No. 85, Gottfried Keller Strasse, Dresden, Saxony, Germany, a Dutch subject, do hereby declare the nature of this invention and in what manner the same is to be performed, to be particularly described and ascertained in and by the following statement:—

The invention relates to the shutter arrangements for photographic cameras and more particularly to mirror-reflex-cameras. An important characteristic of my invention consists therein that the mirror of the finder-arrangement is directly connected with and controlled by the organ or organs the position and movements of which control the time and duration of the exposure. In the practical construction of my apparatus there are arranged two normally light-shutting organs with windows for the light, which organs are coupled by a coiled spring, and are under such control of a hand-actuated lever, that in the case of adjustment for momentary exposure both organs move together, so as to let pass the light for an exposure for a very short moment whilst in the case of adjustment to time exposure the one light shutting organ moves in advance of the other light shutting organ which is held back, until the chosen time for the time-exposure has passed, whereupon by another manipulation of the apparatus this second organ is released and under the influence of the tensioned spring it follows the first organ and shuts off the light. The first mentioned shutting organ has the form of a slide which has the tendency to move upwardly behind the front wall of the camera under the influence of a leaf-spring and which on the other hand may be pressed downwardly by means of a finger-actuated handle and this slide at

the same time carries the above mentioned mirror of the finder-arrangement on the camera.

In order to make quite clear my invention I will explain a preferred embodiment of it with reference to the accompanying drawings, in which:—

Fig. 1 is a sectional elevation of the camera from the rear, on the line 1—1 in Fig. 3, the slide (except its handle) and the shutter being shown partly broken away, the positions of the broken parts being indicated in dotted lines.

Fig. 2 is a front sectional elevation of the camera taken on the line 2—2 in Fig. 3, the position of the lens being indicated at 10 and the slide and the shutter being shown in their lowest positions.

Fig. 3, which is a section on the line 3—3 in Fig. 2, illustrates how the picture is reflected upwards by the mirror to the finder, before the photographic plate is exposed.

Fig. 4 is a partial section on the line 4—4 in Fig. 2.

Fig. 5 is a view corresponding to Fig. 2 but with the slide and shutter in the positions they occupy when a time exposure is being made.

Fig. 6 is a partial front sectional elevation, showing the slide in the same position as in Fig. 5, the shutter and certain other parts being omitted.

Fig. 7 is a plan of the parts shown in Figs. 5 and 6, the walls 18 being in 80 section.

Figs. 8, 9, 10 and 11 are views corresponding to Figs. 5, 6, 7 and 3 respectively, but with the parts in the positions they occupy after an exposure has been completed.

Fig. 12 is a perspective view of a detail.

[Price 1/-]

As can be seen from Fig. 1, an angular lever 1, mounted behind the front wall 18 of the camera, has two noses 2, 3 designed to engage with the handle 5 connected with the slide 4 (Figs. 2 and 3). The angular lever 1 is adapted to pivot around a screw 6 when an extension or trigger 7 of said angular lever is being depressed. The two end positions of the angular lever 1 are determined by a slot 8 with which a screw 9 engages. 10 is the aperture of the camera. 11 is a cross-plate mounted on the slide 4 and serving as a support for the mirror 28 of the finder arrangement, 27 being a bent sheet fastened to the lower side of the mirror 28 and bearing against the lower side of the cross-plate 11. This plate thus constitutes a light-tight pocket equivalent to a bellows. The slide 4 has a stud 14 against which bears the end of a blade-spring 12 which is fixed at 13 in the camera. In a longitudinal groove of the camera there is further arranged a spring 15 with two lateral flaps 16, 17 at the lower end. The flap 17 is of rectangular shape, the flap 16 being triangular.

Between the wall 18 of the camera and the slide 4 a shutter 19 cut out of a metal sheet is inserted, which shutter is coupled with the slide 4 by means of a coiled spring 20, located in the vertical groove 25 and attached with one end 21 to the slide 4 and with the other end 22 to the shutter 19. Behind the front cover plate of the camera is slidably arranged a small adjusting plate 23 which is shown in Figures 1, 6 and 9 in elevation, in the Figures 7 and 10 in plan, and in Figure 12 in its full size in perspective and which, by its particular action still to be described later on, serves for determining whether a time-exposure or an instantaneous exposure will be made.

For the sake of clearness, the angular lever 1 and the plate 23 are omitted from Figs. 2, 5 and 8 (except that the position of the trigger 7 of the lever 1 is shown in the two latter figures); while in Figs. 6 and 9 for the same reason the shutter 19 and the springs 12, 15 and 20 are omitted.

A plug 29 on the adjusting plate 23 extends through a corresponding slot in the wall of the camera to the outside and serves as a handle for the adjustment of the plate 23. The upper part of the plate 23 is bent towards the upper nose 2 of the resilient lever 1. If the plate 23 is in its lower position, shown in Figure 6, it will press the upper nose 2 of the resilient lever 1 into the path of the

handle 5 of the ascending slide 4, as shown in Figs. 6 and 7; if the plate 23 is in its upper position, shown in Figs. 1 and 9, it is quite out of the way of the nose 2, and owing to the spring action of the lever 1, its upper nose 2 tends to keep to the wall of the apparatus and thus out of the way of the handle 5, as is shown in Fig. 10.

The angular lever 1 is continuously pressed in a clockwise direction by the action of a spring 24.

As already mentioned there is fixed on the slide 4 a support 11, upon which the mirror frame 28 rests and which support 11 is adapted to penetrate into the pocket formed by the mirror frame 28 and the above-mentioned bent sheet 27. In consequence of this arrangement the light passing through the objective opening and the lens 10 in Figure 3 is projected upwardly by the mirror 28 to the finder arrangement and is prevented from getting upon the photographic plate, which is ready for exposure behind the mirror in the back wall of the camera. The operation of the afore described camera is as follows:—

Suppose, an instantaneous exposure has to be made; in this case the adjusting plate 23 would be pressed upward, see Fig. 9, so far that its margin 30 is out of the way of the upper nose 2 of the angular lever 1 and the nose 2 of this lever, owing to the natural tendency of this elastic lever 1, will keep clear of the handle 5, when it slides upwards. The apparatus is now fixed in its position, by pressing down the handle 5, until a projection 5¹ on it is caught by the lower nose 3, of the lever 1, whereby the slide 4 connected with said lever adopts the position shown in Figs. 2, 3 and 4. If now the trigger 7 of the angular lever 1 is depressed, the nose 3 releases the handle 5, which, together with the slide 4, moves rapidly upwards. Through this rapid upward movement the following will happen:—When the slide 4 is moving upward, the rectangular flap 17 (see Fig. 4) prevents the shutter-plate 19 from moving upward so that for a short moment it will be retarded with regard to the slide 4. But as the upward movement of the slide 4 continues, the triangular flap 16 (see Fig. 4) is acted upon by the tapered-off end 25¹¹ of the groove 25¹ of the slide 4 so that the spring 15 with its rectangular flap 17 is pushed aside, and the shutter sheet 19, being released, can ascend rapidly and close again the passage of light through the window 26 which has coincided with the

aperture and the lens 10 in the front plate of the camera.

Suppose however that a time exposure has to be taken, the adjusting plate 23 would be shifted down so that its upper bent part 30 presses the upper nose 2 of the resilient lever 1 into the way of the lever 5, see Fig. 7. After that the slide 4 is pressed down by means of the handle 5, so that the projection 5¹ is caught by the nose 3 of the lever 1. The operation is the same as hereinbefore described; with the difference however, that the slide 4 can ascend only until the handle 5 butts against the nose 2 (see Figs. 6 and 7). At this moment the window 26 in the slide 4 registers again with the opening 10 as before and the shutter 19 is still held down by the rectangular flap 17, so as to be out of the way of the light (see Fig. 5). The picture is now being taken by time exposure as long as this position of the parts is maintained. If the photographer wishes to close the camera, the trigger 7 has to be pressed upwardly, swinging thereby the lever 1 round its pivot 6, so that the nose 2 releases the handle 5, enabling the slide 4 to continue its ascending movement as before and act upon the lateral flap 16 to release the slide 19, which now follows upwards rapidly, whereby the aperture 10 is finally closed.

Having now particularly described and ascertained the nature of my said invention and in what manner the same is to be performed, I declare that what I claim is:—

1. Arrangement for photographic apparatus, especially for mirror-reflex-cameras, characterised in this, that the mirror (28) of the finder arrangement is directly connected with and controlled by the slide (4) the position and movements of which control the time and duration of the exposure.

2. Apparatus as claimed in Claim 1 characterised in this, that a lateral support (11) on the slide (4) carries the one end of the mirror (28) the other end of which is hinged near the back-wall of the camera, whilst a light-tight pocket (27), equivalent to a bellows, grips below the support (11), so that the support penetrates between the free end of the mirror and the light-tight pocket or the like when the slide ascends or descends.

3. Arrangement for photographic apparatus, especially for mirror-reflex-cameras as claimed in Claims 1 or 2, characterised in this that the slide (4) is

coupled with a shutter (19) by a spring (20) and both parts are controlled in such a manner that in the case of an instantaneous exposure the slide (4) and the shutter (19) move successively without any hindrance from the finder-position through the exposure position into the closure or end position, whilst in the case of a time-exposure the shutter is retained and the slide (4) moves alone from the finder position into the exposure position, in which it is retained until upon a new actuation of the apparatus the slide (4) is released and moves further on to the end position, whilst the shutter (19) moves behind the slide at once from its first position through the exposure position on to the closure or end position.

4. Apparatus as claimed in Claims 1 to 3 characterised in this, that a bent lever (1) having two noses (2, 3) and a trigger (7) controls the spring-actuated slide (4) with the shutter in such a manner that in the finder-position the one nose (3) retains the slide (4) against the tension of its spring (12) and upon pressure of the trigger (7) releases the slide to follow the pressure of its spring (12) and that the other nose (2) in the case of a time-exposure catches the slide (4) and retains it in the exposure-position until upon an opposite pressure on the trigger (7) the second nose (2) liberates the slide so that it may continue its travel to the end position, whilst in the case of an instantaneous exposure the second nose (2) is kept out of the way of the slide (4) so that the latter is free to continue its travel at once to the end position.

5. Apparatus as claimed in Claims 1 to 4, characterised in this, that a leaf-spring (15) having two noses (16, 17) controls the movements of the shutter (19), its one nose (17) retaining the shutter (19) during the forward movement of the slide (4), until the other nose (16) in the forward movement of the slide (4) is actuated by the latter so as to withdraw the leaf-spring (15) with the first nose (17) out of the way of the shutter (19) so that the latter under the action of the tensioned coiled spring (20) with accelerated speed follows the forward-movement of the slide (4).

Dated this 19th day of November, 1920.

For the Applicant,
LLOYD WISE & Co.,
10, New Court, Lincoln's Inn, London,
W.C. 2,
Chartered Patent Agents.

[This Drawing is a reproduction of the Original on a reduced scale]

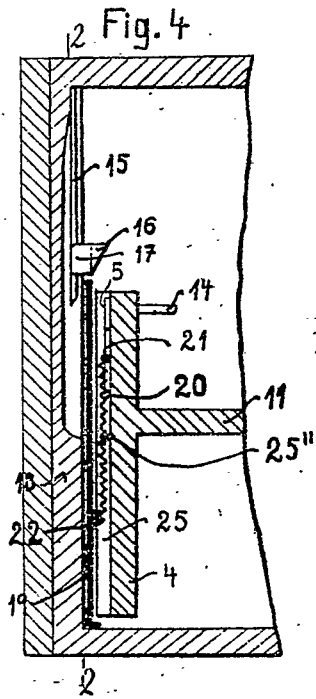
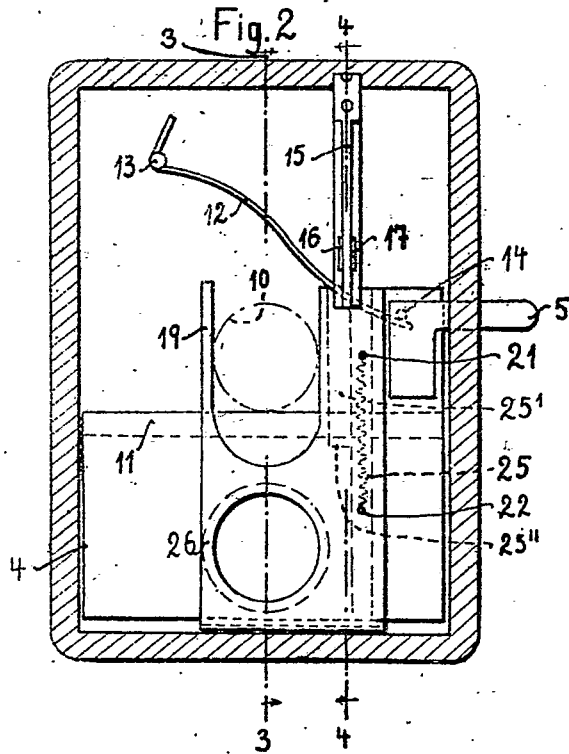
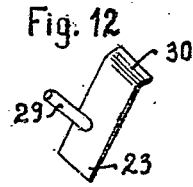
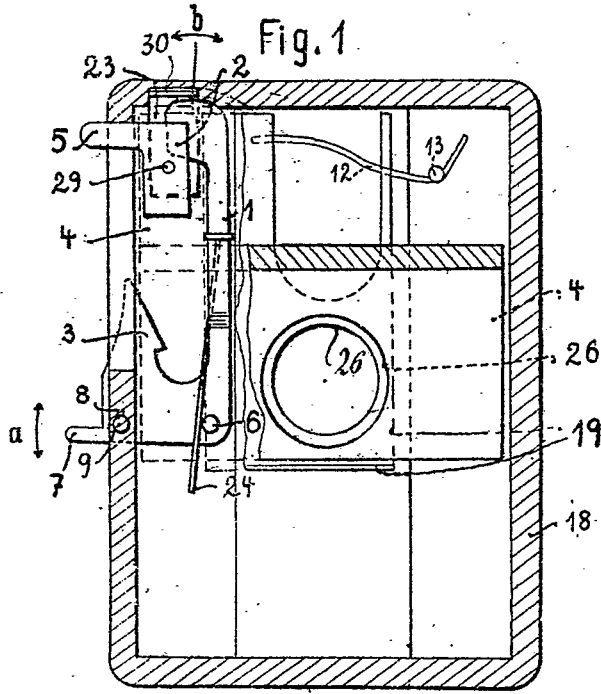

Fig. 3

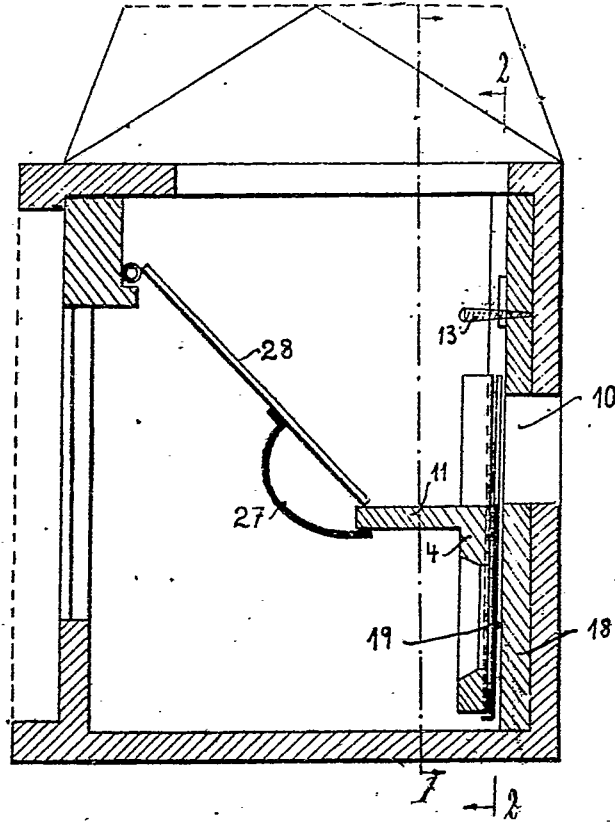
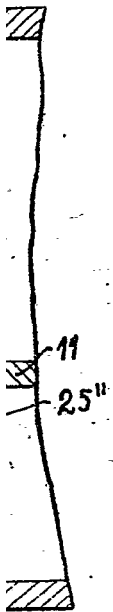
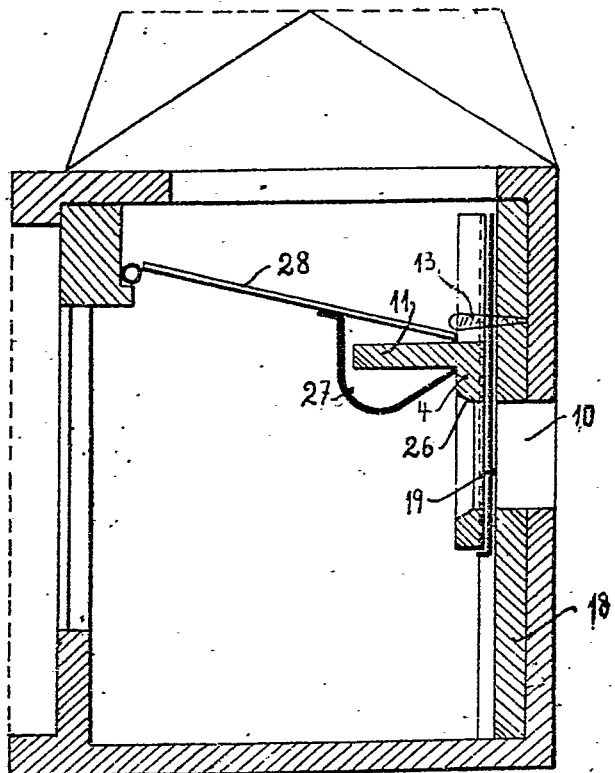
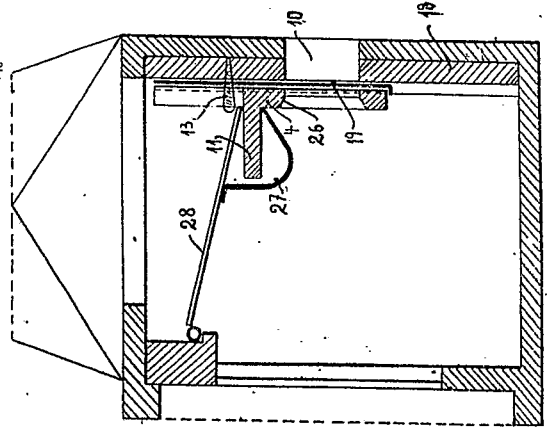
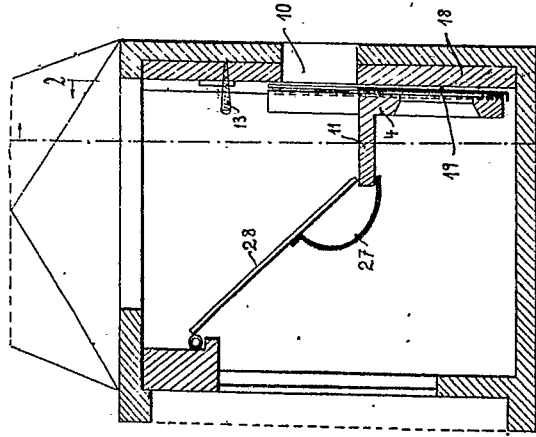
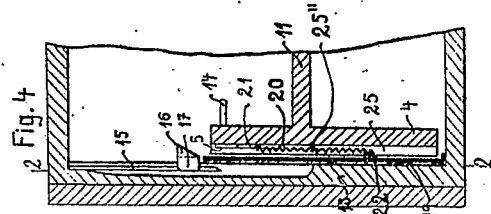
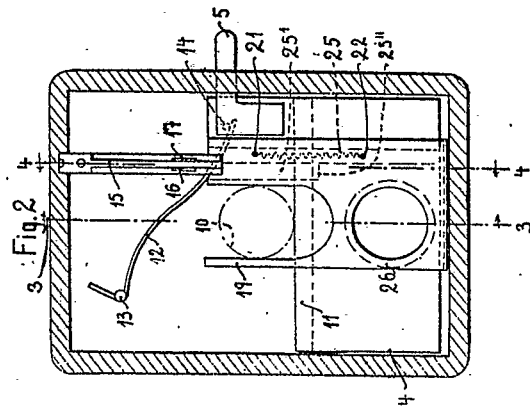
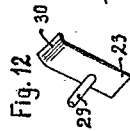
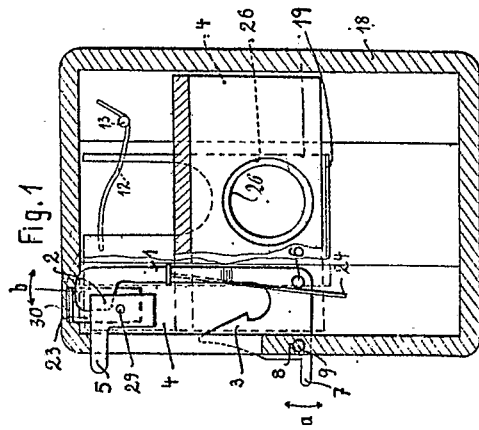

Fig. 11





[This Drawing is a reproduction of the Original on a reduced scale]

[This Drawing is a reproduction of the Original on a reduced scale.]

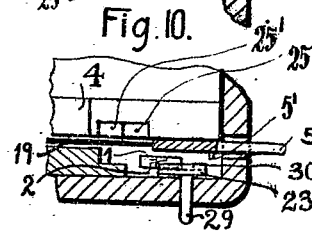
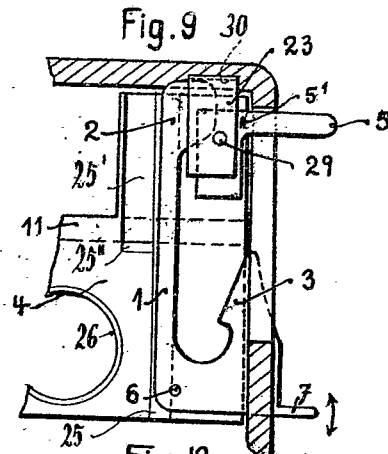
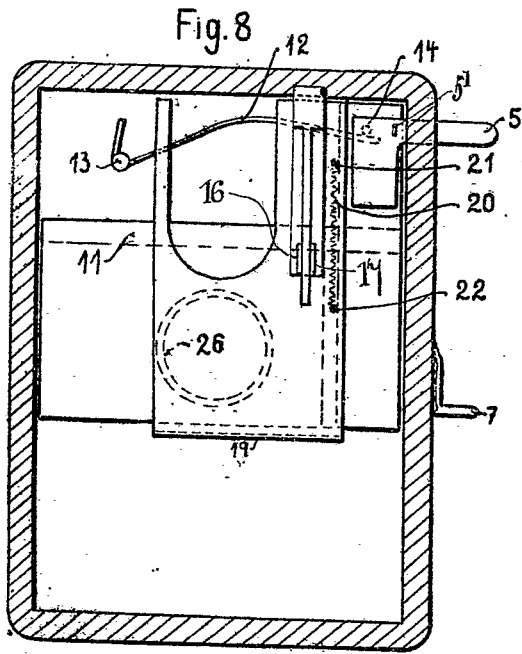

Fig. 5

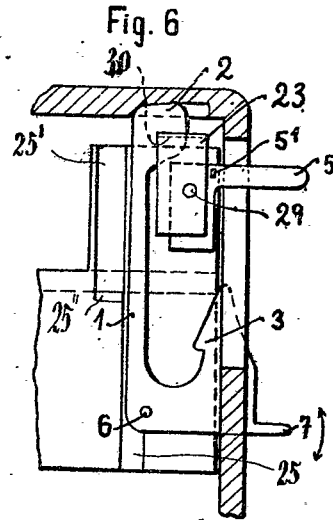
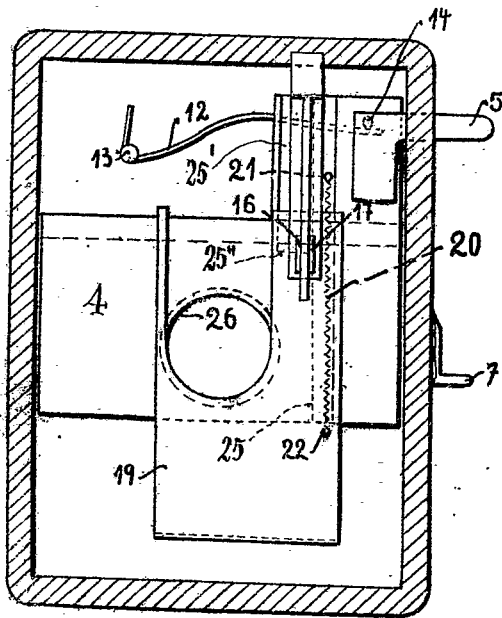

Fig. 7.

