

Exakta News

Issue No. 570

Published by Seymour's-Exakta 350 W. 31 St., New York, N. Y. 10001

Price Increase on German Equipment Averages 30%.

It was too good to last.

In an effort to increase Exports, the German Government established a rather unrealistic exchange rate which favored the American Dollar. You have seen prices of German Equipment drop to an unbelievable level. Cameras which sold for nearly \$300.00 just a few years ago, could be bought for little over \$100.00.

This export boost caused a run-away economy in Germany, known as "The New Prosperity." Isn't that just what Germany wanted? Sure, but with the high-gear economy came the unavoidable danger of inflation. Germany well remembers her devastating inflation of the early twenties. The value of the German currency was eroded to one-billionth of its original value: the buying power of One Billion German Marks was then equal to one single original Mark!

To avoid a run-away inflation, the German Government is now reversing its money policy. While we used to get more and more German Marks for our Dollars, we now have to pay more and more Dollars for the German Mark.

The original increase is 8½%. By itself, this would not be too bad. But "The New Prosperity" caused wages to go up at least 25% and German Export prices have risen about 25% at the factory level. Add to this the new 8½% higher price of the German currency and you have a substantial increase.

So much for the bad news. But there is good news, too: We still have stocks of German Equipment, bought at pre-increase prices. This equipment is available to you at the old prices. Other equipment is being increased gradually to average costs of pre-increase and post-increase shipments. Unavoidably, there are also items which have to be sold at the new increased prices right now.

Read this issue of the Exakta News carefully. Take advantage of the old prices wherever you can. Sooner or later our current stocks will run out. Please send your orders as soon as possible. It's money in your pocket.

We'll do our best ...

to comply with your many requests to bring you the Exakta News more frequently.

This issue brings you many new items. There are new Exakta models, new lenses, new gadget bags, and new accessories. All in all, there are many excellent buys in this issue. Read every line! Read every word! Read this issue from cover to cover! You wouldn't want to miss some of the juiciest bargains, would you?

Happy Hunting!

SEYMOUR'S-EXAKTA



New Exakta Model Follows Users' Tips.

Almost from the day of the introduction of the first 35mm Exakta (the celebrated "Kine Exakta") with its professional range of shutter speeds, users and prospects have deluged the factory with requests for an Exakta with a more limited range of speeds at a lower price.

In a misguided drive for economy, the factory produced a range of cameras known as "Exas." These cameras were not the answer because they disregarded the needs (and wishes) of the users. Moreover, they were poorly designed, from the first Exa I, via the Exa II, all the way to the so-called Exakta

500 which was nothing but an Exa II with a name to which it had no right.

Well, Ihagee, we forgive you, because you have doubly redeemed yourself. You have, mercifully, taken all Exas and Exakta 500's off the market and you have finally come out with a new model based on the wishes of the people who know best what is wanted: the users of the Exakta.

The new model is known as the Exakta VX-500. The Exakta VX-500 is a full size Exakta, a real Exakta. It can use all Exakta

Lenses. It can take all Exakta Finders, from the plain waistlevel finder to the most sophisticated BTL Prism. It has the instant-return mirror. In fact, it is virtually identical to the Exakta VX-1000 except for the shutter speeds which range from 1/30 sec. to 1/500 sec.

Now, for the first time, you can start your Exakta System with an inexpensive (VERY inexpensive!) camera body, build your system around it, and trade it for the more complex model whenever you are ready. Now, for the first time, you can buy a second inexpensive camera (just the body, or a complete camera) and still retain complete interchangeability of all your accessories.

The new Exakta VX-500 is a full-fledged Exakta, not a scaled-down, cheap "Exa" or "Exakta 500."

Vive la difference!



55 — 90mm TAKUMAR Zoom

Zooms from "normal" range through "portrait" range. A wonderful lens for theatre work, sports photography, portraits, flowers, etc. Includes the range of a standard focal length lens. Take several shots of your subject in rapid succession, all "from a different distance" without moving your camera.

Focal length: 55—90mm
Aperture range: f4—f16
Formula: 7-element
Angle of view: 43°—27°
Minimum distance: 5 ft.
Diaphragm: Preset with click-stops
Focusing system: Helicoid action simultaneous w/zoom
Marked focal lengths: 55-60-65-70-75-80-85-90mm
Overall length: 4 in.

Case \$4.95

Shipping 95¢

58⁴⁰



90mm F2.8

Schacht Travenar

If you have paid a visit to our showroom, you have seen the giant enlargement of an orange. This enlargement is a 16-diameter blow-up, better than 250 times in area: you could put 250 original 35mm slides on the print! This enlargement is not only a tribute to our color work but also to the unbelievable resolving power of the lens that took it. Every tiny pore on the skin of the orange is clearly and sharply delineated.

The shot was taken (by Mr. Seymour, of course) with the Schacht 90mm F2.8 Travenar.

The Travenars are of the cocking type automatic construction which is especially useful for Behind-the-Lens Metering but will work just as well without the meter. The sharpness of these lenses is truly amazing. The optical formula is an improved Tessar Type which makes use of the very latest breakthrough in rare-earth glass.

Amazing as the performance of these lenses is, our price for the Travenars is even more amazing.

Brand New 90mm F2.8 cocking automatic Travenar
Seymour Special, only \$39.95
Case \$3.95. Shipping \$1.25

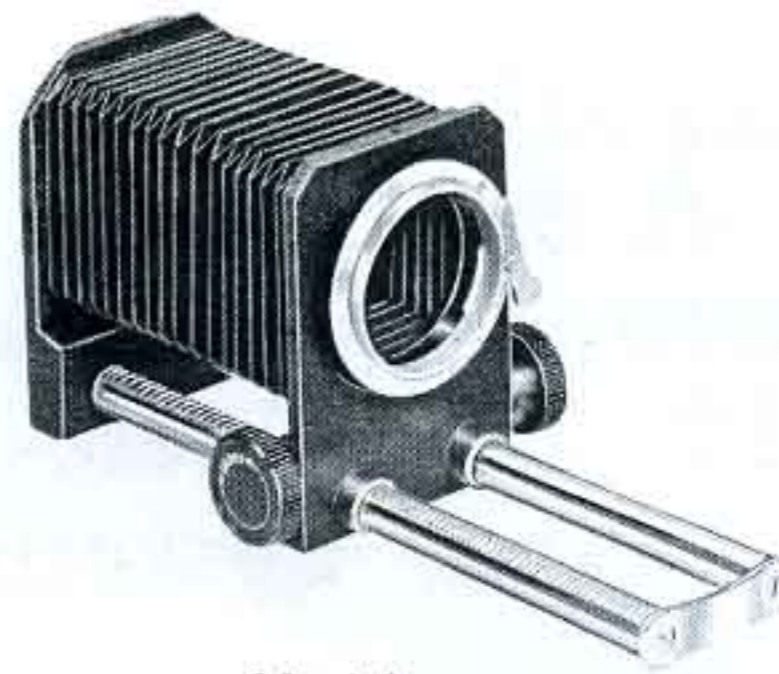

Models
TW-5 and TW-7

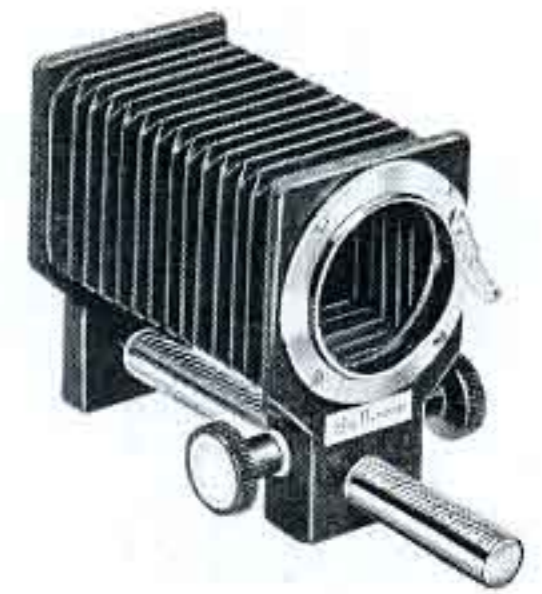

Model
MR-05

New Models

Exakta Bellows

NEW TWIN-ROD MODELS:

With geared Rack-and-Pinion Precision Focus

Model TW-5, Full 5-inch Extension...\$17.95 + 95¢ Shipping

Model TW-7, Extra Long 7" (180mm) Extension....\$19.95 + 95¢ Shipping

NEW MONORAIL MODEL:

With geared Rack-and-Pinion Precision Focus

Model MR-05 Full 5-inch Extension..\$13.95 + 95¢ Shipping

Short Barrel Lenses

for Use in Bellows

These lenses are especially corrected for use in bellows for a wide range of close-up ratios. They render sharp, crisp, well color-balanced pictures. Their longer focal length provides a convenient working distance with plenty of room to light your subject adequately.



100mm F3.3 preset Travegar \$19.95 + 95¢
135mm F4.5 preset Travenon \$19.95 + 95¢

Our Top-of-the-Line Twin Rod Bellows Unit with extra long Seven-Inch Extension (Model TW-7) plus your choice of the 100mm F3.3 or the 135mm F4.5 preset Short Barrel Lens

Save

an additional \$5.15

\$34⁷⁵
+ 95¢ Shipping



Hugo Meyer (Meyer Optik) Gorlitz 35mm F4.5 preset Primagon.

Full 65 degree coverage — sharp from corner to corner — brilliant color rendition — flat, distortionless image — smooth-acting preset diaphragm stops down to F22, Weighs only 6 oz. and is only 1¾ inches long — focuses to less than 1½ ft. An excellent wide angle lens!

Don't miss this wonderful buy at

19⁹⁵ Case \$3.95
plus 85¢ shipping

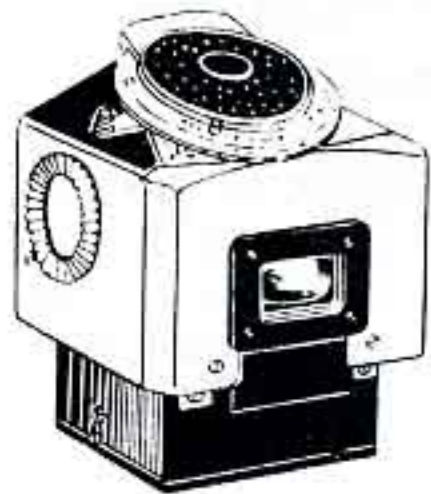

New Model Travemat Through-the-Lens BTL Light Meter Prism System

When the first model Travemat was announced it was something of a mystery to many Exakta Owners. By now, just about everybody knows that it measures the light AFTER it has passed through the lens and that it sees exactly the same amount of light as the film. However, there are quite a few things about this system that many Exakta users have not quite realized.

Let's take regular scenic photography first. The Travemat has two independent sensors. It measures the light just below the horizontal center line and slightly to the right and left of the vertical center line. The result is an intelligent reading of the light intensity, totally eliminating the glare from the sky. Experienced photographers point a hand-held meter downward for exactly the same reason. You "point" the Travemat exactly at the scene you want to photograph and its "brain" does the "thinking" for you. The Travemat is a true Point-and-Shoot Meter.

Where the Travemat really shines is in all types of photography where you ordinarily would have to use Exposure Compensation. Say, you shoot with a Polarizer on the lens. By what factor do you have to increase the exposure? Forget it! The light that goes through the lens has already passed through the Polarizer and the Travemat "sees" only the usable light just as the film does. It does not care why there is less light. It measures what it sees. You don't care either: You completely IGNORE all compensating factors. You shoot as if you had never heard of a filter factor. The Travemat has done all the "compensating" for you. That goes for any filter factor. With the Travemat you just ignore it.

Here's something else: Has it ever occurred to you that not all your lenses may be calibrated correctly? How can you know whether your lens is really F5.6 when you set it at F/5.6? Anyway, F/5.6 is not an absolute figure as far as light transmission is concerned. It is merely a mathematical ratio of the diameter to the equivalent focal length. Certain standards have been adopted to make F stops less arbitrary but the fact remains that you cannot check the accuracy of the F stop settings on your lens. The Travemat (and you) couldn't care less. The Travemat does not see the markings on your lens. It sees the light that passes through your lens. While the two values might vary considerably, the only true value is the one the meter sees! All of a sudden, your exposures are correct. You may surprise yourself by getting perfect shots from lenses that used to give you blueish pictures before you used the Travemat.

Of course, the Travemat is totally indispensable in Macro Work. Remember what you had to go through, to compute your exposure? Extension, magnification, filter factors and on and on. You had to be an expert evaluator of the various influencing factors and you had to be able to translate all these factors into exposure speed and F stop adjustments. And you had to be a mathematician. Now you let the Travemat do it all for you. Concentrate on taking your Macro Photographs instead of wasting most of your time figuring and calculating and wondering where you made your mistake. The Travemat takes ALL variables into consideration. Your exposures will be correct.

Operation of the Travemat is simplicity itself: After you set the ASA rating of the film and the shutter speed, you watch the indicator needle (which you see in the viewfinder) as you vary the lens opening. As soon as the needle shows between the brackets, you shoot.

No matter what kind of shots you take, the Travemat will make picture taking easier and foolproof, even under the most difficult conditions. What's more, every single one of your shots will be perfect.

We supply the Latest Model Travemat BTL System PentaPrism with Fresnel Lens and MicroGrid for \$49.50 + 1.35 Shipping Charges. The new redesigned and greatly improved model is in stock for immediate shipment.

Micro-Grid vs. Split Image

Hardly a day goes by that does not bring several letters from customers telling me that they are confused about the various focusing screens. The question most often asked is: Mr. Seymour, why do you recommend the Micro-Grid, and why do you prefer it to the split-image gadget?

Let me begin by explaining the two methods of focusing. The old fashioned split image rangefinder has two small wedges in the center of the screen. The eye, looking for the sharp image, will find the image either above or below the focal plane. In either case, the wedges will displace the image. As you focus the lens, the image will eventually move into the correct plane and there will be no more displacement. The "broken" line becomes continuous. Theoretically, this works fine. But unless you relax your eye completely, you will psychologically move the image into the plane where the image becomes "unbroken." You think you are in focus but you are not. You have to learn to use the split image or you will not get it to work. Even though the image "moves," the split-image has no moving parts and the "moving" is done by the nerves controlling your own vision.

Now don't get me wrong. Thousands of Exakta users swear by the old split-image gadget and we still sell a large number of these screens. If you know how to use it, we have it in stock and we won't fight you if you order one.

The "Micro-Grid" is a new optical development. Its main advantage: sharp focus is achieved regardless of the user's eyesight. The Micro-Grid superimposes a grid pattern over the image when the lens is out of focus. Once in focus, the grid disappears and the image appears crystal clear. Unlike the split-image, the Micro-Grid does not black out. With the Micro-Grid there is no guesswork: you are either in focus, or out. The Micro-Grid is now available in a combination screen: A light-gathering Fresnel Screen produces a brightly illuminated viewing image (bright from corner to corner). The Micro-Grid is in the very center and around it is a ring of ultra-fine groundglass for a quick visual check of the focus (for the doubting Thomases who don't trust any rangefinder and must be re-assured by a back-up device).

Yes, you still have your choice but I do recommend the Micro-Grid. It is easier to use than the old split-image glass and it is more accurate. I personally also find it faster to use, but I won't argue this point.

Anyway, whatever your preference, here's what you can order:

Split Image Insert \$6.50 + 35¢

Combination Fresnel Viewing Screen with Micro-Grid and Finegrain Matte-Glass Ring

Original Ihagee Exakta Produce \$7.50 + 35¢

Independent Make (also very good) . \$5.95 + 35¢



Want a "Status" Pro Bag?

We don't go for status equipment just for the sake of status. But if a status item offers so much more in real usable value, and if it gives much more than mere status, AND if it is still reasonably priced for its quality, we're all for it.

You will find this new addition to our line of Gadget Bags not only the best-made and best-looking, but also the most useful of all equipment cases.

What's a Pro Bag? A Pro Bag is a gadget bag, made of solid thick leather with two straps which come together at the top to form a carrying handle. In addition, it has a heavy duty shoulder strap. You sling it over your shoulder or you carry it like a suitcase. That's a Pro Bag.

But this description goes for any pro bag. What makes our "Status" Pro Bag so much better? Well, for one thing, it is entirely handcrafted by American Craftsmen whose saddlemaking skill was handed down from father to son. The top grain leather is hand waxed to a beautiful, easy-to-care-for finish. The interior is lined with rich golden plushy lint-free velvet. The extra-wide-flare shoulder strap has a built-on non-slip shoulder pad. The brass hardware is lacquer coated to resist wear and maintain its beauty. Two buckled tripod loops securely hold your tripod. The key-lock keeps out inquisitive eyes (and hands!). Our "Status" Pro Bag has a unique snap-open top compartment. You can conveniently open this outside-access compartment without removing the bag from your shoulder.

The size of our "Status" Pro Bag is more than adequate for the Exakta Owner who has quite a bit of gear. Yet it is not unreasonably bulky. The Dimensions are 11" x 6-3/4" x 9-1/2".

The Manufacturer's Retail Price is \$53.00. Compared with what we've seen on the market, this is a very low price for this type of saddlemaker's craftsmanship. Seymour's wouldn't be Seymour's if we would ask you to pay the retail price. You may order the finest Equipment Case you've ever seen, the "Status" Pro Bag, from us for an unbelievably low \$39.95 + 2.35 Shipping Charges. Status, Quality, Beauty, AND Usefulness. At that price you might as well treat yourself to the very best. Live a little!



Low Cost Life Insurance for your Lenses

If you love your lenses, protect them from all hazards and prolong their useful life. Our new Lens Pouches are soft as a glove, lined with luxurious plushy velvet, and have drawstrings for quick and easy opening and closing. Less bulk than ordinary lens cases. More "cuddle" for your fine lenses. Also recommended for delicate accessories. Three sizes: Small \$2.85 + 25¢, Medium \$3.85 + 25¢, Large \$3.85 + 25¢.

How long is long?

Professional photographers know it but most amateurs are totally unaware that a lens of moderately long focal length gives the most pleasing results for "people" shots. In fact, no professional would give up his medium length "telephoto" lens for all the rice in China. Strangely, most amateurs have not yet discovered this type of lens. Mention "Telephoto" and they'll immediately think of a 135mm lens. A 135mm lens is fine and it's probably the most logical choice for the first telephoto lens you buy. But think about it: could it be that for many shots a 135mm lens is too long? Did it ever occur to you that a 135mm lens, in one fell swoop, jumps from the full area your 50mm lens gives you to an area less than one-seventh in size? Sounds incredible, right? If you don't believe it, square the focal lengths and divide. See? I told you!

Obviously, this is too big a jump. You need something to bridge the gap. Something that gives you one third, or perhaps one quarter the area. Using your newly learned formula, you quickly figure out that a 90mm lens gives you about a third, while a 100mm lens gives you exactly one quarter the area. You need this "in-between" focal lengths for all shots for which the 50mm lens is too short and the 135mm too long. Perhaps you don't quite see it by just reading about it; but once you have used your "medium" lens, you'll use it for more shots than either your normal lens or your 135mm lens. Once you have used it, you wonder why nobody ever told you about it. Why? Because most people don't even know that such lenses exist!

It is true that there aren't too many lenses in this focal range (which runs from 85mm to 105mm); but some of the very best lenses are in this category. The reason may be that the market for these lenses is made up of a very high percentage of professionals.

Take your pick from these excellent lenses:

85mm F1.9 preset Super Coligon \$44.50 + 1.25 Shipp'g. Chgs.

90mm F2.8 cocking automatic Travenar \$39.95 + 1.25

100mm F3.5 fully automatic Steinheil Cassarit \$44.50 + 1.25

100mm F2.8 fully automatic Steinheil Macro-S \$179.40 + 1.25

105mm F2.5 fully automatic Rokunar \$59.50 + 1.25

And don't forget another lens that fits in here:

55/90 preset Tamron Zoom \$59.50 + 1.25

Velvet Lined Pouch for any above \$3.95

Hard Case for any above \$4.95

Exakta Eveready Cases

A case for every taste. A case for every pocketbook. A case for every model camera, for every combination of body, finder, and lens. As Exakta Specialists, Seymour's-Exakta brings you the greatest choice of camera carrying cases. We have more than a thousand cases in stock. Dress up your camera! Protect your camera! Buy a new case for it!

#66 Standard Exakta Case, non-detachable front \$7.85 + 95¢

#69 Deluxe Exakta Case, detachable front \$9.85 + 95¢

#77 Deluxe Exakta Case, metal trim,
detachable front \$14.50 + 95¢

#83 Deluxe Exakta Case, Metal Trim, detachable front
Extra High Top (takes Exakta with BTL Meter) \$17.85 + 95¢

#93 Deluxe Exakta Case, detachable, Extra Large Front
(takes camera with regular prism with Macro-S Lens)
\$17.85 + 95¢

#97 Deluxe Exakta Case, detachable, Extra Large Front
and Extra High Top (takes camera with Macro-S Lens
and BTL Meter) \$19.85 + 95¢

Please order by Number and Description.

**Schacht Quality
+ Seymour Price
= Best Buy**

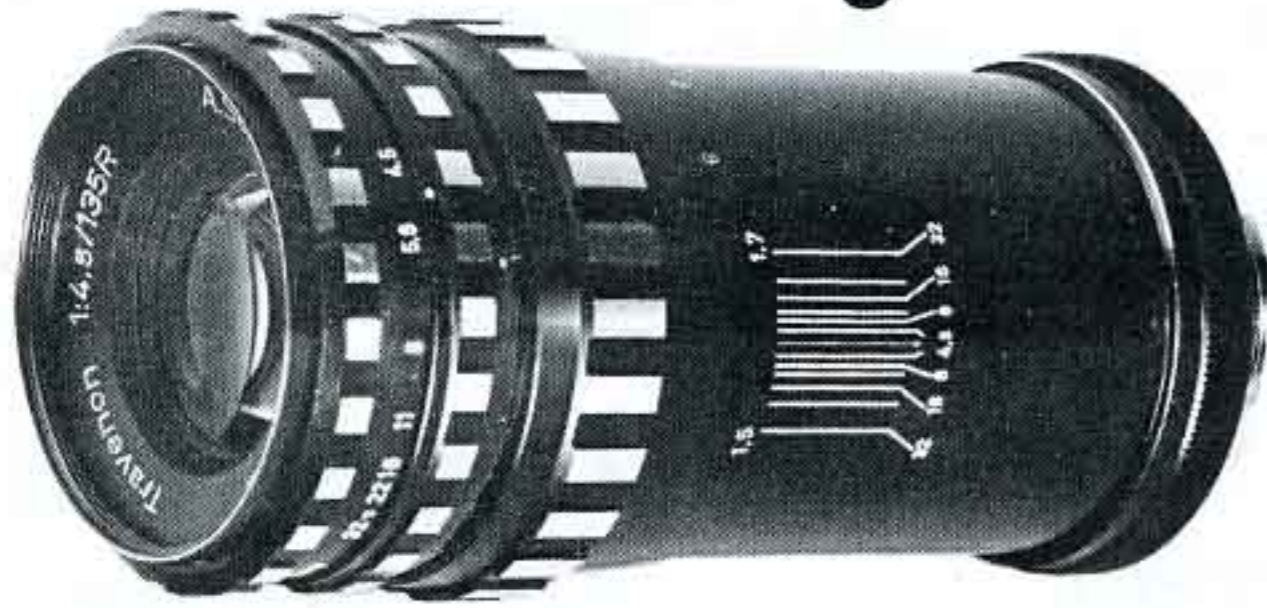

Only Schacht could have made this wire-sharp Lens. Only Seymour's could have offered it at such a price.

If you are a speed demon and must have super fast lenses, the 135mm F4.5 Schacht Travenon is not for you. But —, if you want wire sharp correction and if you can live with a preset lens (without automatic), the Schacht Travenon is the buy of a lifetime.

Discontinued as a victim of the speed craze, this telephoto lens holds its own when compared with any lens, regardless of price: Color Correction and Sharpness are unsurpassed. The mount reflects German Workmanship at its proudest.

We know quality when we see it and bought every last lens the manufacturer had to offer. No more when these are gone. Don't miss this Buy!

135mm F4.5 preset Schacht Travenon Telephoto Lens for Exakta \$19.95 + 95¢ Shipping Charges. DeLuxe Velvet Lined Lens Pouch \$3.95. (Lens accepts 49mm Accessories).

Dupliscop Slide Duplicator

There are two types of camera buffs.

Type A enjoys complicated Rube Goldberg style setups, the more complicated, the better. He proudly tells you how he hooked up tubes, bellows, a discarded piece of stovepipe, the left lens from Uncle Paul's eyeglasses, two hundred and seventy dollars' worth of assorted custom-machined couplers and adapters and . . . oh, he almost forgot to tell you what he was going to do with the rig: he was going to duplicate some slides. Well, he didn't have all the bugs out of the setup, but once it was ready . . .

And there is Type B who enjoys getting results by just pushing a button. If he wants to duplicate slides, he just wants to put a gadget on his camera, drop a slide into the gadget, push the shutter button and come up with a perfect copy.

If you are Type B and have been searching for a self-contained "thing" that makes perfect duplicates of your slides without additional accessories, search no further! You have found it:

The new DUPLISCOPE is a self contained slide duplicating "rig." Nothing else is needed, no tubes, no bellows, no auxiliary lenses, no stovepipes, not even a lens! It's all in the Dupliscop, including a special flat-field copying lens. You bayonet the Dupliscop directly into your Exakta, drop a slide into the Dupliscop and shoot. Slides can be unmounted, mounted in cardboard or glass, or they can be in the form of film strips. You can use any light source, even daylight. The result: a perfect exact copy every time. No reduction, no enlargement: Exact same size. Want to make negatives from slides? Want to make black-and-white slides from negatives? No problem!

The DUPLISCOPE is Seymour-priced at only \$27.50 + 95¢ Shipping Charges. Remember: it is entirely self-contained. Nothing else is needed. Not even a lens!

EXAKTA VX 500



A new FULL SIZE Exakta for the Exakta Fan who does not want to pay for fancy speeds he never uses.

Do not confuse the new Exakta VX-500 with the defunct so-called Exakta 500, Everybody knows that the "Exakta" 500 was nothing but an Exa. Mercifully, the factory has retired that mis-named model. The Exakta VX-500 is really an Exakta, full size, and with full interchangeability of finders, etc. For a fuller description please refer to the Feature Article on Page One: "New Exakta Model Follows Users' Tips."

Exakta VX-500 with Model C Waistlevel Finder with captive groundglass with F2.8 fully automatic Meyer Optik Domiplan \$49.95 + \$7.85 for the case (mandatory) and \$1.95 Shipping Charges.

Exakta VX-500 with PentaPrism with Fresnel Viewing Screen with fully automatic genuine Jena Tessar F2.8, as shown above, \$64.50 + \$7.85 for the case (mandatory) and \$1.95 Shipping Charges.



ORIGINAL IHAGEE WAISTFINDER

If you are not using the waistlevel hooded finder, you are wasting half the possibilities of your Exakta. (No pun intended). Indispensable for low angle shots, copying, close-up work, right angle (secret) photography, etc. Comes with fold-away magnifier.

Model C with captive groundglass
Special Sale 8.95
Model N (takes interchangeable
glasses) \$11.95
Glass Inserts for Model N same as
for Prism.
Case for Waistfinder \$ 2.95
Shipping: 95¢

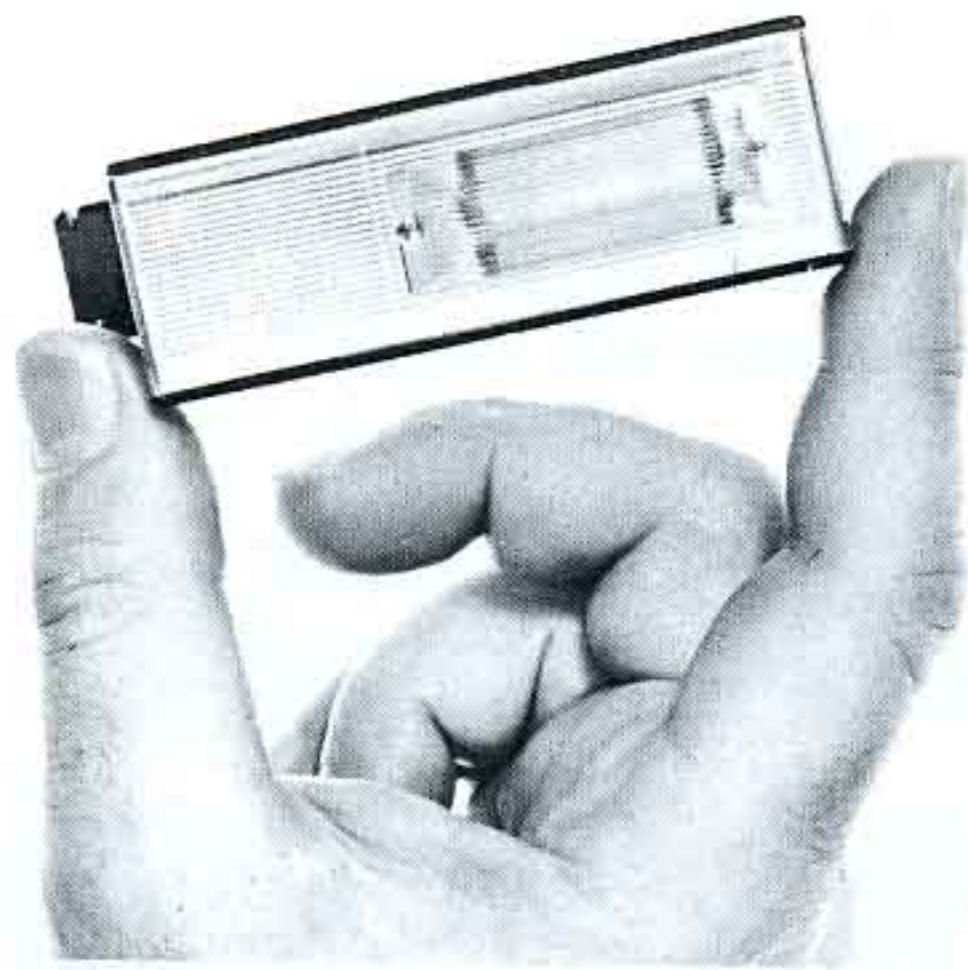

New Strobe has Perma-Power

Many customers have asked me to find a strobe unit which is powerful, unusually small, equipped with re-chargeable Nickel Cadmium Batteries and built-in charger, and which they can buy without mortgaging their home. It should have all the features of a hundred-dollar unit except one: the hundred-dollar price tag!

All right, I found it: the new German PERMA-POWER HELIOTRON Electronic Flash Unit. Unbelievably compact, a mere 2½ x 3¼ x 1¼". Unbelievably powerful, an honest Guide Number of 40 for Kodachrome II. Unbelievably light in weight, a mere seven ounces. Ruggedly constructed and hand crafted in the true German tradition.

It comes complete with rechargeable power source and with built-in charger. Fast re-cycling (8 seconds) and uniform light output make it the choice of the professional. True palm-size compactness makes it the choice of the amateur. Use it indoors from any AC outlet or use it "cordless" anywhere from its own nickel-cadmium battery-powered energy source. Re-charge the NiCad Batteries as often as you want - they will never "wear out."

The new Heliotron Perma-Power Strobe is equipped with a new Gold Toned Flash Tube. Now, at last, color slides will no longer have the bluish cast that makes skin tones look pale and unnatural. The light from the gold toned flash tube has sunny daylight quality; it produces beautiful, natural skin tones as well as more pleasing overall color quality.

HELIOTRON PERMA STROBE, specially Seymour-priced at an unbelievably low \$29.95 + 3.95 for the case and \$1.25 Shipping Charges.

SWAP!

Trade up to the very latest
EXAKTA VX-1000TL

Prices are for the exchange of bodies without lenses and finders:

Exakta VX-1000 and \$49.50

Exakta VXIIB and \$54.50

Exakta VXIIa, VX, or V and \$59.50

Shipping Charges \$1.95 per camera.

Send your camera by insured parcel post.

Enclose your order and remittance.

Steinheil Macro-S Lenses

Time has finally caught up with the price of the famous Steinheil Macro-S Lenses. We held the price as long as humanly possible. But the German currency re-valuation, the creeping increase in production costs and the new German wage scales have taken their toll. The new price will be \$210.00 per lens. However, since the factory now needs eighteen months delivery time, we cannot, at this time, accept orders for the Macro-S lenses with the exception of the 135mm Macro-S Tele Quinar.

We still have a small supply of the 135mm F2.8 Steinheil Macro-S Tele-Quinar Lenses which we can sell at the old price of \$159.50 + 1.25 Shipping Charges, as long as our supply holds out.



135mm F2.8 Automatic Steinheil Macro-S Tele-Quinar

Last time

at this price

\$159.50

Shipping Charges \$1.25

| | |
|---|--------|
| Original Steinheil Screw-in Shade | \$3.95 |
| DeLuxe Leather Case | \$4.95 |
| Series VII 54mm Filter Adapter | \$4.95 |
| Series VII Drop-in Filters, each | \$3.95 |
| Rotating Polarizer, Custom, 54mm | \$9.50 |



Exakta VX-1000TL

Latest 1970 Exakta VX-1000TL, Original Ihagee PentaPrism, Combination Fresnel Viewing Screen and MicroGrid Focusing Aid, fully automatic genuine Jena 50mm F2.8 Tessar Lens, \$87.50 plus \$7.85 for the case and \$1.95 Shipping Charges.

Same, but with F2.8 fully automatic Meyer Optik Domiplan, \$79.50 plus \$7.85 for the case and \$1.95 Shipping Charges.

Same, but with F/2 fully automatic genuine Jena Pancolar \$99.50 plus \$7.85 for the case and \$1.95 Shipping Charges.

Buenas Notches!

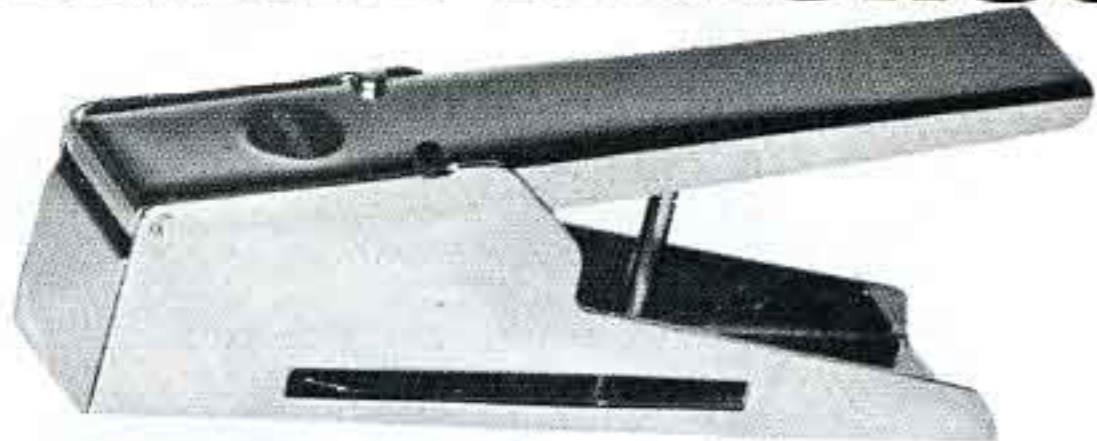

Why do slides have to be "notched?"

When we introduced the new Slide Punch, we thought everybody knew what it was for. Not so. While nobody actually asked for a recipe for the punch, we did get many letters asking how and why.

WHY: Cardboard mounted slides have four identical edges and two identical sides. Did you know that there are eight (yes, eight!) ways to put a slide into a projector, a magazine, or a viewer? Obviously, only one of the 8 positions is correct. Slides can be upside down, on their sides, reversed (so that COCA COLA signs read ALOC ACOC in mirror writing) or reversed AND upside down, or reversed AND on their sides, etc.

There is only one way to prevent this embarrassing interruption of slide shows: Punch a notch into the cardboard which tells you visually (when it's light) and by touch (when it's dark) which way the slide "goes." When you place the slides into a magazine, the lined-up notches immediately signal any slide whose notch does not line up with the rest of them. The punch gadget is designed to put all the notches in exactly the same spot on all slides.

HOW: You drop the slide into the punch and press. Your slide comes out with a visible and "feelable" notch.

Once your slides are notched, it is impossible to insert them in any of the seven wrong ways. Without guesswork, without time-consuming trial-and-error, all your slides are quickly lined up correctly. No more "Oops! Sorry!" when you project your slides, no more embarrassment, no more mood-killing interruptions.

The Slide Punch is an all-metal Precision Instrument and is priced at only \$2.95 + 35¢ Shipping.

Minimum Mail Order

The high basic cost of filling orders (paper work, handling, packing, addressing, shipping, etc.) forces us to establish a minimum of \$5.00 for all Mail Orders.

We do realize that occasionally small Emergency Mail Orders may not add up to \$5.00 We will accept such small Emergency Orders but must make a Service Charge of \$1.00 to help defray the unusually high cost of processing such orders. Thank you very much for your cooperation.



1970 Exakta VX-1000/TL available for immediate shipment

The new Exakta VX-1000TL is loaded with features. No matter how hard you look, you won't find another camera which comes even close in versatility, ease of operation, user-oriented construction and precision engineering. In addition to the well known features of all the former Exakta Models, the new 1970 Exakta VX-1000TL has: Instant Return Mirror, Retro Counter, Short Stroke Rapid Film Advance, Black Non-Glare Dials. It has a Streamlined Body, Self-Aligning Combination Rewind Clutch and Rewind Crank Handle. "No-Hands" Rewind Button. Improved Slow Speed Mechanism. Improved Back Safety Catch. New Hi-Flect Mirror, New Type Safety Light Trap.

These are just some of the ADDITIONAL features. I take it for granted that all you good customers know the BASIC features of the Exakta. It would take too many pages to list them, from the interchangeability of lenses and finders to the 29 shutter speeds (NO other camera has such a range of speeds!). From the optional Behind-the-Lens Exposure Meter Prism to the three separate synchronizers (an Exakta Exclusive!). From the famous Film Cutting Knife (another Exakta Exclusive!) to the Cartridge-to-Cartridge Film System which gives you your choice: rewind or don't rewind. All other 35mm SLR cameras are just Johnny-come-lately copies of the Exakta whose original construction, still basically unchanged, emerged in 1937!

And it should not be necessary to point out that German Workmanship has never been equalled anywhere in the world.

You may think that I am prejudiced. But I am not. I am as open minded as anybody and have been trying out many makes of cameras. After all, you cannot really know your own line if you don't compare it with others. The answer - just look at my pictures in our showroom. Every last one is an Exakta shot. Try as I may, I have never been able to duplicate my Exakta work, no matter what camera I use. No, I am not prejudiced, but I am SOLD on the Exakta.

You can buy bodies from us, or just about any component, finder, focusing insert, lens carrying case; or you can buy complete cameras with lens, with and without Behind-the-Lens Metering System. Please refer to the listing in this Issue of the Exakta News. Look under "Exakta Cameras." If you don't find the combination you want, drop us a line and ask.

And if you can convince a few of your friends that they should buy an Exakta and nothing but an Exakta, don't forget to tell them that Seymour's specializes in the Exakta and nothing but the Exakta.

SEYMOUR'S-EXAKTA
350 West 31 Street, New York, N. Y. 10001

Exakta Specialists for over 20 years

SAFARI Foam Fitted Attache Case



If you are a Seymour Customer of long standing, you know that it isn't idle talk when we say that we will drop an item from our list, if something better becomes available. Best Sellers on our list are no exception.

For many, many years our Foam Fitted Attache Case has been one of our most successful items. Now, thousands of cases later, the original case must succumb to progress! A new type of injection moulding produces a moulded luggage shell which is virtually impervious to impact damage. To distinguish the new from the old, the new Foam Fitted Attache Case carries the name SAFARI.

Imagine the hazards a case of this sort will have to stand up to on a safari. This new Attache Case overcomes them all. Heat cannot damage the material. While we have never tested the case with a herd of trumpeting elephants stampeding over it, we have a hunch that it would even withstand this kind of impact. Normal hard use (including the tender loving care the airlines give your luggage when it's out of your sight) will neither dent nor break it. Humidity, even rain, cannot damage the contents: the top fits into the bottom by a male profiled rim that engages a female profiled rim to protect the contents from any kind of moisture.

Just like the old model, the new SAFARI Foam Fitted Case cushions your equipment and protects it from jolts. The foam cushions come uncut and you custom fit the case for your equipment: you trace your equipment on paper, cut the foam cushions right through the paper. The whole thing takes only a few minutes.

Now for the best news: you buy the new SAFARI Case at exactly the same price as the old model. And if you consider that it's still the same price as in 1964, you see what a great buy this is:

SAFARI Foam Fitted Attache Case, Seymour-priced at only \$19.65 + 1.65 Shipping Charges.

Close-Out

We still have a supply of the previous model Foam Fitted Attache Case. Progress in new and better materials has overtaken this faithful servant which has served thousands of customers over the years. While they last, and on a first-come, first-served basis, you may order as many of these cases as you want, at a 40% reduction from our regular price. The close-out price is \$11.79 + 95¢ Shipping Charges.



What's a Jena Werra?

Quite often, customers ask me to recommend a camera which will produce excellent pictures but which can easily be slipped into a coat pocket or milady's pocketbook. Some customers want such a camera for themselves as a "constant companion;" others want it for the younger members of the family (in which group I gallantly include their wives!); still others want it for gifts for birthdays or other occasions and for bonus gifts for employees or customers.

I am sure you remember the Werra Camera which I offered a little over a year ago. When I saw the camera I was carried away by my enthusiasm and made a huge commitment. In fact, I bought the entire inventory the factory had to offer. I don't have to tell you that in less than two months every last camera was gone and that we had to return hundreds and hundreds of orders unfilled.

Now, just in time for the main "shooting" season, I was able to buy another model of the Werra Series. Again I bought the entire inventory. Again there won't be enough to go around. Remember: first come, first served.

Let me describe this new Jena Werra Camera to you: It is a full frame 35mm camera yet it is hardly larger than the palm of your hand. It comes equipped with the fabulously sharp 50mm F2.8 genuine Jena Tessar. The shutter has a range from one full second to 1/500 sec. Other features include: Coupled interlocking film advance and shutter cocking; Double Exposure Prevention; Blank Exposure Insurance; Full Synchronization for Flash and Strobe; Automatic Exposure Counter; Delayed Action Self Timer. The screw-in lens shade reverses to form a dustproof cover over lens and shutter. The Jena Werra is beautifully designed, and finished in chrome and black leather-grained vinyl.

And now I'll shock you with the price! We sell the complete outfit. It breaks down as follows: Jena Werra Camera with 50mm F2.8 genuine Jena Tessar \$19.95 (that's NOT the price of the lens alone; that's the price of the whole camera, lens and all! In fact, you KNOW you couldn't buy a Jena F2.8 Tessar for that money!) The Reversible Shade with the Screw-In Cover is \$1.95. The Ever-Ready Metal Trimmed Case is \$4.95, and there is a shipping charge of \$1.95. Please remember that I can sell only the complete package because that's the way I had to buy them.

If I didn't assure you that the price is not a misprint, I would probably get a few thousand letters asking me to verify the prices. Yes, the prices are correct: Camera \$19.95, Shade and Cover \$1.95, Everready Case \$4.95, Shipping \$1.95. So don't write and ask questions! Order before they are all snatched up! Buy one for yourself, several for your family and many as gifts. You CAN'T go wrong.

Rokunar Lenses



Rokunar (of "Sharp-as-a-Rokunar" fame) has extended its line again. Rokunar Lenses are prized by their owners for their superb resolving power and 100% correct color correction. Every Rokunar proudly carries its name. You can now choose from this impressive list:

28mm F2.8 fully automatic Rokunar 69.50 + 1.25 (Case \$3.95)
 35mm F2.8 fully automatic Rokunar 59.50 + 1.25 (Case \$3.95)
 105mm F2.5 fully automatic Rokunar 59.50 + 1.25 (Case \$4.95)
 135mm F2.8 fully automatic Rokunar 59.50 + 1.25 (Case \$4.95)
 200mm F3.9 fully automatic Rokunar 79.50 + 1.35 (Case \$5.95)
 200mm F4.5 preset Rokunar 49.50 + 1.25 (Case \$4.95)
 300mm F5.5 fully automatic Rokunar 89.50 + 1.65 (Case \$6.95)
 85mm to 205mm fully automatic
 Zoom Rokunar 139.50 + 1.95 (Case \$7.85)

New! Ingenious!
Internal Automatic Elongar
Tele Converter couples internally.
Doubles Focal Length.
No outside rods.
Optically matched to Rokunar Lenses
a genuine Rokunar Product.
Only \$19.50

Master Showman Projection Pointer

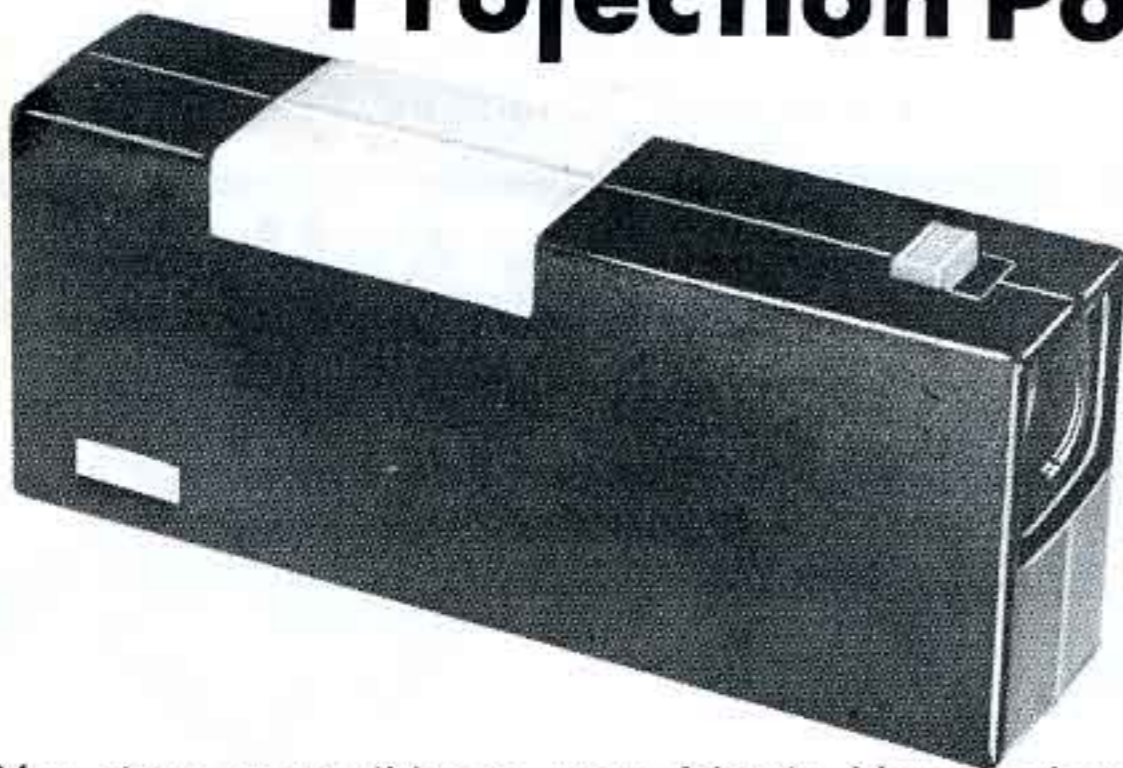

You show your slides to your friends. You are in the middle of your slide show. Now you want to point out a detail on the screen. What do you do? Walk to the screen, your shadow nicely blocking the slide and point out the detail? No! You project a brilliant white arrow with the new Master Showman Projection Pointer right from the back of the room. Adds a professional touch to your slide show.

The new Master Showman Projection Pointer is a radical departure from old fashioned projection pointers. The design sports an ebony black square (yes, square!) housing. The Battery Compartment slides open for quick change. The Bulb Compartment snaps open and shut for easy replacement, even during a show! An opal translucent part of the housing sheds unobtrusive subdued light for slide selection, reading of captions, change of magazines or adjustment to the projector. No more annoying switching on of bright lights and no more fumbling in the dark.

The Master Showman Projection Pointer superimposes a sharp arrow on the screen. One-finger on/off button. One-finger focusing button adjusts the sharpness of the arrow according to the distance from the screen. Effective even in large rooms.

Add the finishing touch to your slide shows with the new Master Showman Projection Pointer, Seymour priced at only \$6.95 + 45¢ Shipping. (Batteries and Special Bulb included).

Rokunar does it again!



Rokunar brings you the new 200mm F4.5 preset Tele-Rokunar!

Gone are the days when 200mm Telephoto Lenses were heavy, clumsy, large Big Berthas. In a major break-through in optical design, Rokunar (of "Sharp-as-a-Rokunar" fame) threw the excess size, weight, and bulk over board. The new 200mm F4.5 preset Tele-Rokunar is about the size of a 135mm lens. In fact, it is smaller than the 135mm F3.5 Meyer Primotar! Fully preset, smooth-acting diaphragm. Ultra high correction for minute detail. Cuts distance by 75 per cent!

The 200mm F4.5 preset Tele-Rokunar is unbelievably low Seymour-priced at a mere \$49.75 + 4.45 for the case and \$1.25 Shipping Charges.

Small in size, light in weight, and sharp as a Rokunar! Try it on Seymour's Fifteen-Day Money-Back Trial basis.



28mm F2.8 Auto Rokunar

A Bargain is a Bargain ONLY if there is no compromise in quality! Here is such a bargain: Seymour's-Exakta brings you the New Series 28mm F2.8 Auto Rokunar, the Ultra Wide Ultra Fast fully automatic Wide Angle Lens for the Exakta. Totally free from distortion and sharp right into the wide-wide corners! Rokunar Lenses (of "Sharp-as-a-Rokunar" fame) are prized by their owners for their superb resolving power and 100% correct color correction. This new 28mm Extreme Wide Angle Lens proudly carries the name Rokunar!

28mm F2.8 Auto-Rokunar Wide Angle, only \$69.50 + 1.25 Case \$4.95. Filter Adapter \$4.50 .

SEYMOUR'S
The Exakta Specialists

Travelling?



I have been privileged (and I use the word advisedly) to read the original manuscript of a book which will be available at the time this newsletter reaches you. Hundreds of books are being submitted to us. So far, only a handful have impressed us enough to offer them to our customers. But this new book really made us sit up and take notice. It is called "Photography for the Traveler" and contains the most complete, useful, indispensable information for everybody who takes his camera on a trip, be it a short vacation or an extended trip around the world. Never before has this kind of information been available in such authoritative form. In fact, most of this information has never been available at all.

As I was reading the manuscript I realized that nobody ever realizes the problems that arise when he takes his camera on a trip. It seems we only realize this when it's too late. We are just not prepared for these problems and we usually have to solve them the hard way, the costly way, or they may simply remain unsolved.

If you had to gather the information contained in the book you would have to spend thousands of dollars. Obviously, the publishers did. If you follow just one single suggestion from the book you will not only save more than the price of the book but you will also insure the success of the photographs you take on your trip.

The book is so full of precise information (not a word of generalities anywhere!) that it becomes difficult for me to single out the "important" part of the contents. Just about everything seems to be important. I cannot urge you strongly enough to read this book BEFORE you take your camera on a trip. Let me mention a few of the chapters that impressed me most. There is the basic information how to plan the trip, what equipment to take along (and what NOT to take along!). There is an amazingly intelligent checklist what to do before you leave. You are told where to keep your equipment, how climate affects film and cameras, how to have film developed away from home. International Customs Regulations are discussed. There are ideas for better travel pictures, what to photograph (people, places, things); how to put fun and interest into your travel pix. How to shoot sequences that tell a story (not so easy as it sounds, unless you are told). What to do inside museums, churches, etc. How to shoot night scenes. How to shoot night scenes. How to shoot title slides right on location. There are charts covering virtually everything from film speeds to exposures to filters, and on and on. And for those who plan a trip abroad there is even a list of photo phrases in foreign languages. They didn't forget anything! It's an amazing book that will do more for you than almost any book I have ever seen. In fact, even the stay-at-homes should have a copy. It's worth having.

We have made up a little "Photographer's Travel Kit." It contains the above Book PHOTOGRAPHY FOR TRAVELERS, plus the new enlarged and illustrated Edition of Binno Garasu's DEPTH-OF-FIELD BOOK (with actual depth-of-field tables for all lenses for all distances) plus a nifty little miniature TRAVELER'S TOOL SET consisting of a tiny hammer, a small screwdriver, a small Phillips screwdriver, a piercer or punch, and a small auger to start screws in wood; all tools fit a small handle which locks them securely in a tiny precision chuck). The whole PHOTOGRAPHER'S TRAVEL KIT, namely the two books and the tool set, costs you only \$4.75 plus 25¢ Shipping Charges, and, take my word for it, it's the best investment you'll ever make.

COLOR SERVICES

May I take this opportunity to thank all you nice people who have been kind enough to write us such nice letters about the quality of our Color Work.

We cannot compete with machine-made, mass-produced "photo finishing" and, frankly, we do not want to. If a photograph is good enough to be enlarged, only the very best individual hand made work will do it justice. Customers for whom we make color prints tell us again and again that they cannot get such brilliant color work elsewhere at prices that come even close to ours.

Let us bring out the true beauty that is hidden in your pictures!

16" x 20" Competition Type Color Enlargements:

First Print \$29.50
Additional Enlargements from same original \$19.50 each
Mounting on Heavy Board \$2.00 per print
Dust Spotting, color matched, by hand, \$2.00 per print
Matte Finish (prints must be mounted) \$1.00 each
Shipping, one to 6 prints \$1.95. Seven or more, free.

11" x 14" Home Display Color Enlargements:

First Print \$12.50
Additional Enlargements from same original \$8.50 each
Mounting \$1.50 each. Spotting \$1.00 each
Shipping, one to 11 prints \$1.50. 12 or more, free.

8" x 10" DeLuxe Custom Enlargements:

First Print \$6.85 (Minimum Color Order \$10.00)
Additional Enlargements from same original \$4.95 each
Mounting \$1.00 each. Spotting \$1.00 each.
Matte Finish (prints must be mounted) 75¢ each.
Shipping, one to 11 prints \$1.00. 12 or more, free

Repeat Offer of a Sell-Out

F2.8 Automatic Jena Tessar



First I must apologize to the many customers whom we had to disappoint by returning, unfilled, their orders for the new 50mm F2.8 fully automatic genuine Jena Tessar. Please send us those orders again. We can now fill them, as long as our new supply holds out.

Let me quote from the article in the December Issue of the Exakta News: The new fully automatic Original Jena 50mm F2.8 Tessar Lens is excellent for every type of photography from landscape work to the most exacting scientific or medical close-up work. The results are magnificent in clarity of detail, 100% true color rendition and balanced contrast. The lens is entirely free from flare or internal reflection. There isn't the slightest trace of optical distortion. No matter how many lenses you now own, you should have this new Tessar.

Prices going up? Of course, but it would not be fair to ask those who are now re-ordering to pay a higher price than their original order. And all you new buyers might as well benefit from this and get the Tessar at the old price:

Brand New, latest Model, Fully Automatic 50mm F2.8 genuine Jena Tessar \$27.50 + 95¢ Shipping.

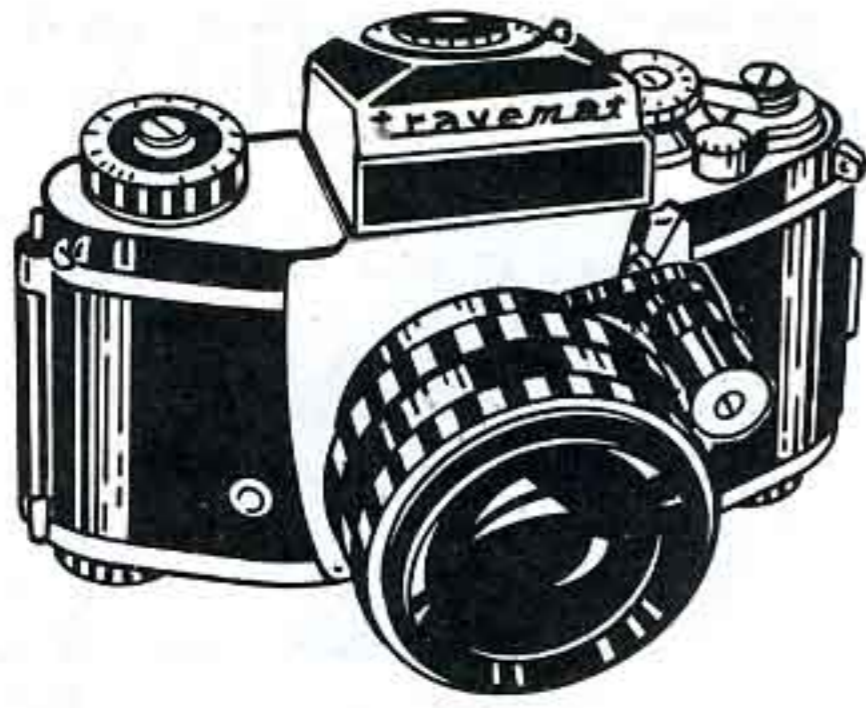

**Fully
Automatic
135mm
F2.8
Steinheil
Tele Quinar**



Latest 1970 Exakta VX-1000TL/BTL, with New Model Travemat Behind-the-Lens Metering Prism with Combination Fresnel Viewing Screen and MicroGrid Focusing Aid with F2.8 fully automatic Meyer Optik Domiplan \$109.50 plus \$17.85 for the special Case with Extra High Top and \$1.95 Shipping Charges. Same, but with fully automatic F2.8 genuine Jena Tessar \$117.50 plus \$17.85 for the case and \$1.95 Shipping Charges. Same, but with fully automatic F/2 genuine Jena Pancolar \$129.50 plus \$17.85 for the case and \$1.95 Shipping Charges. Cases come factory packed with cameras. Purchase of case is mandatory.

Word-of-Mouth Recommendation has made this lens the most popular 135mm Telephoto Lens.

Its reputation is well deserved! It is a truly excellent lens, both optically and mechanically. The 100% color correction brings out all colors in their original glowing beauty. The Resolving Power is close to the theoretically possible maximum and guarantees razor sharp pictures with clear detail and crisp contrast.

The lens is beautifully designed. It is only 3 inches long! It comes in a non-glare ebony black finish. You can switch from fully automatic operation to "Manual" by merely pushing a button. The lens has an In-Line Shutter Release in an all-metal Automatic Activator Housing. A true Steinheil Quality Lens!

135mm F2.8 fully automatic Steinheil Auto Tele Quinar Seymour-priced at **89.50**
DeLuxe Case \$4.95. Shipping 95¢
Original Steinheil Screw- in Shade \$3.95.

**Seymour's-Exakta Offers
Famous Exakta Lens
Below Dealer Cost**

An incredibly lucky purchase enables us to bring you a fabulous Macro Lens at an unbelievably fabulous price. The lens needs no introduction; it is none other than the famous Macro Kilar! Praised for its ultra sharp correction and its unusual focusing range (from Infinity to four inches), the Macro Kilar has been the subject of many articles in professional journals. Among scientists, medical photographers, and close-up fans, the Macro Kilar has an almost fanatical following. And the reputation is well deserved.

The 40mm F2.8 preset Macro-Kilar Model E works equally well as a wide angle lens at normal working distance, as a mid-range lens at moderate close-up distances, and as an extreme close-up lens at a range as close as four inches. Needless to say, the focusing range is unbroken and continuous.

The Dealer Net Cost of this lens is \$100.00. The User Net Price is \$150.00. We made a lucky purchase of a limited quantity of these highly desirable lenses and offer them on a first-come, first-served basis below dealer cost. Please order right away. When we say that we have only a limited quantity, we mean just that. This is a "one-shot deal" and once they are gone, there will be no more.
40mm F2.8 Macro Kilar Model E \$89.50 + 4.95 for the case and \$1.25 Shipping Charges.



Small Accessory Bags

Close-out, various sizes, but all about 10" wide. Zipper Closing. Heavy Duty Vinyl, beautifully grained. These accessory bags sold in our regular stock from \$4.95 to \$7.95. Now, if ordered at the same time as \$10 worth of merchandise: One for \$2.00 + 35¢ Shipping Charges. Three for \$4.95 plus 65¢. No choice of style or size at these prices. Special Offer good as long as they last. First come, first served.

Micro Grid

A new ultra precise Focusing Screen for the Exakta. The Micro Grid is surrounded by a light-gathering Fresnel Screen
Special Seymour Price

7.50
+ 35¢

New Bayonet Mount

If your camera has the old single bayonet mount, you can now obtain the new original double bayonet mount (as supplied on the Exakta VXIIa). Remove the old one by loosening four screws and attach the new one. Takes a minute. \$7.50 postpaid.

Seymour's Inst-A-Dapters

At last there is a solution to a vexing problem: How to use custom screw-in accessories on lenses with DIFFERENT threads. Most Exakta Owners have a good selection of 49mm Accessories because many Exakta Lenses have a front thread of 49mm. What happens when you buy a lens with, say, a 54mm thread? No need to buy all new accessories: Seymour's new Inst-A-Dapters will let you use your 49mm Accessories on your new lens with 54mm front thread. Seymour's Inst-A-Dapters are of special ultra-thin construction to eliminate vignetting. Order any combination shown below:

| Model No. | Has Male Thread: | Has Female Thread: |
|-----------|------------------|--------------------|
| IA-4952 | 49mm | 52mm |
| IA-4955 | 49mm | 55mm |
| IA-5249 | 52mm | 49mm |
| IA-5254 | 52mm | 54mm |
| IA-5449 | 54mm | 49mm |
| IA-5452 | 54mm | 52mm |
| IA-5455 | 54mm | 55mm |
| IA-5549 | 55mm | 49mm |
| IA-5552 | 55mm | 52mm |

Price Reduction

Seymour's
Inst-A-Dapters

2⁷⁵
+ 25¢

Any 3 for **6⁹⁵**
+ 50¢



+ 10

Auxiliary Close-Up Lens

for ultra close-up work
No exposure increase!
Series VII

4⁹⁵
+ 25¢

In case we haven't repeated it often enough:

**15 DAYS TRIAL
AND MONEY BACK
on every item in this folder**



ORIGINAL IHAGEE PENTA PRISM
without Insert\$14.50 + 95¢ Shippg.
Fine Grain Groundglass Screen . . \$3.95
Fresnel Screen with Rangefinder . 6.50
Fresnel Screen with MicroGrid . . 7.50
Case for Prism 2.95

Seymour's Guaranteed Exakta Repairs

Seymour's-Exakta is fully equipped to handle all repairs on Exakta Cameras. We use original factory parts and factory methods exclusively. Our technicians know what they are doing. All repairs are fully guaranteed for one full year. Cost Estimates are free and given without obligation on your part.

Send your camera by insured parcel post. Attach a tag to the camera itself giving your full name and address and stating briefly but clearly what you would like to have done to your camera. Mark the tag: "Estimate Only."

Most repairs require only ten working days from the time we receive your OK. Some difficult or complicated repairs may take somewhat longer and at certain peak periods we may need a little extra time. Remember that all work is done with our traditional thoroughness; we never rush the work, even during peak periods. Our One-Year Service Guarantee protects you, always.

Send your camera now. We are ready to put it in first class operating condition.



Screw-in Rotating POLARIZER

Did you know that there are very few exceptions to the rule that EVERY picture should be shot through a Polarizer? Without a Polarizer, glare obscures color. Roofs, roads, cars, leaves look whitish grey in direct sunlight because they reflect the bright sunlight as glare. A Polarizer cuts through the glare and brings out the true colors which are normally hidden under the glare. Flowers look more natural. Leaves look green. A Polarizer also kills the glare that makes it difficult to photograph through glass (car or train windows, showcases, museum display cases, framed-under-glass pictures). The Polarizer will make the glass "disappear". And, most important, a Polarizer makes the sky take on a deeper blue and clouds show up fleecy white.

Screw-in Rotating Polarizer Ser. VII \$9.85 49mm \$10.85 Postage 25¢

A Personal Message . . .

At a time when new single lens reflex cameras are springing up like weeds, you may ask why I feel the Exakta is still your best buy, quality-wise, feature-wise, and investment-wise.

I have been specializing in Exakta Equipment for many, many years. Now, in the face of an avalanche of "new" single lens reflex cameras, I had to re-evaluate the situation. After weighing all the points, my decision was obvious: Continue to be an Exakta Specialist! Continue to devote all efforts to the "care and feeding" of Exakta owners!

Over the years we accumulated Exakta knowledge unmatched anywhere. We *live* with Exakta Equipment — we know it *thoroughly*. Specialized Consultation and Specialized Exakta Service are at the disposal of our customers. Unbiased advice and expert help have brought us friends from the four corners of the world.

What I am trying to say is, simply, this: If you are serious about getting the finest single lens reflex camera, get the Exakta. If you value the facilities, services, and ready-to-help knowledge of a specialist, buy your Exakta where it has a "home" as long as you own it, buy it from Seymour's.

Sincerely,
Earl F. Seymour.



Meyer Optik 400mm F5.5 preset Tele Megor

Very latest Model. Super Sharp. Rotating Tripod Mount. Positive, preset diaphragm. Non-glare ebony-black finish. No vignetting. Fastest, most brilliant, most highly corrected 400mm lens.

89⁵⁰
+ 1.85
Postage

Jena

180mm F2.8 Sonnar



The famous
fully automatic
Olympia
Sonnar

159⁵⁰

and 1.95 Shipping

In case we haven't repeated it often enough:

**15 DAYS TRIAL
AND MONEY BACK**
on every item in this folder

SEYMOUR'S - EXAKTA

The World's Only *Exclusive* Exakta Dealer

New Grip-O-Matic Flash Bracket

Grip Handle tilts
but Flashgun
remains vertical.

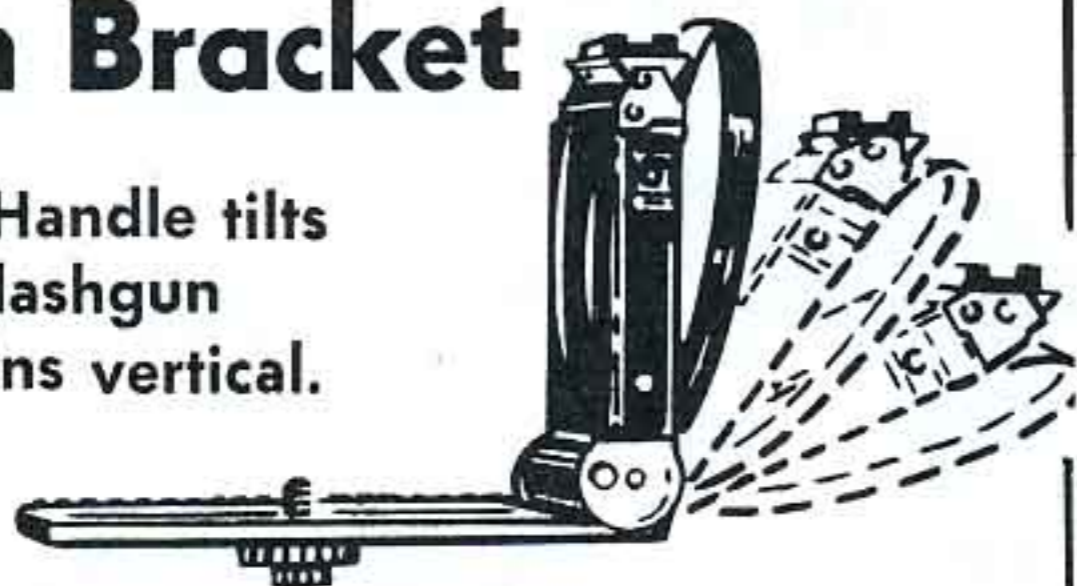

A newly developed accessory, a combination of: a Camera Grip; a Flash Bracket; and, with the special coil cable, a Remote Shutter Trigger. The anatomically shaped ebony-black grip handle adjusts (by pushbutton action) to the angle that feels most comfortable. But, amazingly, your flash or strobe remains level through internal parallelogram action. A Safety Hand Strap prevents the camera from slipping out of your hand and lets you carry it by the grip without fear of dropping it. A superbly engineered quality product.

Grip-O-Matic Flash Bracket
with Cable Tripper

675 + 45¢

New! Cube Gun!



Envious of the owners of Instamatic Cameras because they can use the new flash cubes? Let Thompson-Seymour's come to the rescue. Our new Flash Cube Gun permits the use of Flash Cubes on ANY camera. BC circuit. Quick-turn geared cube movement. Shoe Mount. PC coiled synch. cord.

395

15 V Battery 90¢
65¢ Shipping

Stock No. 21749
Cube not incl.

SLIDE PUNCH

PREVENTS
UPSIDE-DOWN
OR
REVERSED SLIDES



Notch your slides and banish embarrassment forever! You CANNOT insert slides the wrong way! A precision all metal instrument. Makes a wonderful gift, too.

Seymour-priced
at only

295 + 35¢ Shipping

**15 Days Money Back
on ANY item
in this folder**

Extra-value

135mm F2.8 Automatic Rokunar

Sharp as a Rokunar

You have heard this slogan many times. Rokunar Lenses are standard equipment of our leading professional photographers. We bring you the genuine

135mm F2.8 AUTOMATIC
ROKUNAR TELEPHOTO LENS

Only **59⁵⁰**

plus \$4.95 for the Case. Shipping \$1.25.

Made
in
U.S.A.



Made
in
U.S.A.

The utmost in Luxury

These trim Luxury Gadget Bags feature the finest Top Grain Cowhides available. Highest Quality U. S. Workmanship throughout - the Best!

Heavily padded top. Finest Hardware. Heavy-Duty Zipper (and we mean HEAVY Duty!) Lined with soft felt for added protection of delicate equipment.

Adjustable inside Belting separates accessories and holds them securely.

Double Size Outside Pocket. Zippered Inside Pocket. Adjustable Extension Carrying Strap.

Bag measures a generous
12 by 10 by 6 inches.

Top Grain
Cowhide Gadget Bag

29⁹⁵
+ 1.65
Shipping

Special Seymour Price

From JENA, the undisputed Optical Capital of the World Seymour's-Exakta brings you the new automatic ultra-sharp

35mm F2.8 Orig. Jena MACRO FLEKTOGON

When they re-design a lens in Jena, the World's undisputed Optical Capital, they don't just change the color of the mount from bright to black. They don't just arbitrarily change the filter size. They re-design the lens from the raw rare-earth glass up. In fact, they don't just re-design or "improve" it: They perfect it!

The wizards of Jena (which, incidentally, is pronounced "YAY-nah") have come up with an entirely new Wide Angle Lens which doubles as Macro Lens (or, if you prefer, a Macro Lens which doubles as Wide-Angle Lens, because we don't really know what came first) the fabulous 35mm F2.8 fully automatic Jena MACRO-Flektogon.

The correction is superb. The detail and the correction are unbelievable. The Focusing Range reaches from Infinity to four inches. All without tubes, without bellows, without auxiliary lenses!

In jena, they find YOUR optical problems and SOLVE them!--- One of the most difficult problems of close-up photography is the Compensation of Exposure which becomes necessary when you focus close-in. So, the wizards of Jena built a little computer (or whatever it is called) right into the lens which automatically compensates accurately for the difference in exposure. As you focus, the diaphragm opens automatically in the exact ratio of the loss of illumination. In practical terms this means that you use the settings your meter tells you and leave everything else to the lens. now, for the FIRST TIME, you get correctly exposed close-ups without even bothering to remember such things as exposure compensation, calculating, measuring distances, or what have you. If your meter says F/8 -- you set the automatic diaphragm on F/8 and let the lens do the worrying, the figuring, the compensating and the allowing for extension and magnification. You just compensate on your composition, and SHOOT!

35mm F2.8 Orig. Jena

FULLY AUTOMATIC

Macro Flektogon



Seymour-priced
at an
unbelievably low

89⁵⁰

Shipping 1.25

Case \$4.95. Filter Adapter \$4.50.

"Toshiba"

You may have seen the name Toshiba on an imported television set. If you are a research scientist you may have seen it on an Electron Microscope. But if you have been to Japan, you know that Toshiba is the "General Electric" of Japan, one of the world's largest manufacturers of electric and electronic equipment from Transistor Radios to Military Radar Systems. Pronounce it TOE-shee-bah, stressing the "TOE"

Toshiba has just come out with a new Cadmium Sulfide (CdS) Exposure Meter, the brain child of a giant company, the PE-1.

The world's film manufacturers will run out of film speeds before the PE-1 will: ASA 6 to ASA 6400! Your camera will run out of F stops before the PE-1 will: F/1 to F/32! And try to match its range of speeds: 8 minutes (not seconds) to 1/8000 sec.! Really easy to use: "One Touch" Operation! And you hardly know you are carrying it: just 3 1/2 ounces! And most important: regardless of price, the Toshiba PE-1 is the most accurate meter in our stock.

Why do we tell you all about this meter which sells for less than \$20 when we have been doing quite well, thank you, selling other meters for over \$50.00? Sure, we like to sell high-priced equipment with a healthy mark-up. But — when we like a piece of equipment, we say so. True, we cannot make \$20 on the Toshiba PE-1 because we sell it for \$16.95. But it's such a fine meter that it would not be fair to our customers to hide it. We know it's good. It is your best investment in picture quality. Buy it!

Toshiba PE-1 Ultra Sensitive CdS Meter. Seymour-priced at \$16.95 plus 95¢ postage, and with every meter we will give you the tiny battery and the case free. No matter how many meters you now have, order the Toshiba - on our recommendation!



Toshiba PE-1
Seymour
Special **16⁹⁵**
Battery & Case included Post

Ultra Sensitive CdS Meter Toshiba PE-1

"One Touch" Operation

ASA 6—6400
F/1 to F/32
8 minutes to 1/8000 sec.!

Weights only 3 1/2 oz.

Truly ACCURATE!

Close-Up Set Combination

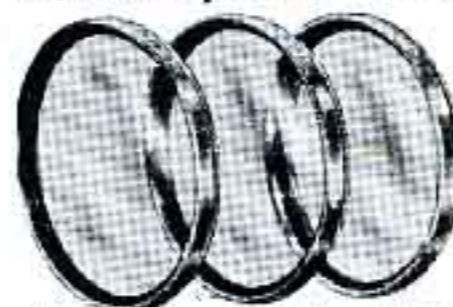

+1
to
+6

The Set consists of 3 high quality coated optical lenses in threaded chrome mounts. Use them singly or in combination, from Plus One to Plus Six.

Be sure to mention Model wanted: Model VII fits any Series VII Filter Adapter. Model 49 screws directly into Biotar, Auto-Tessar, Pancolar, Xenon, Quinon, Quinaron, and all lenses with this thread. Leather Case included.

12⁵⁰

Plus 85¢ Postage.

Sale!

50MM

F/2 Automatic

JENA

PANGCOLAR



39⁹⁵

+ 95¢ Shipping

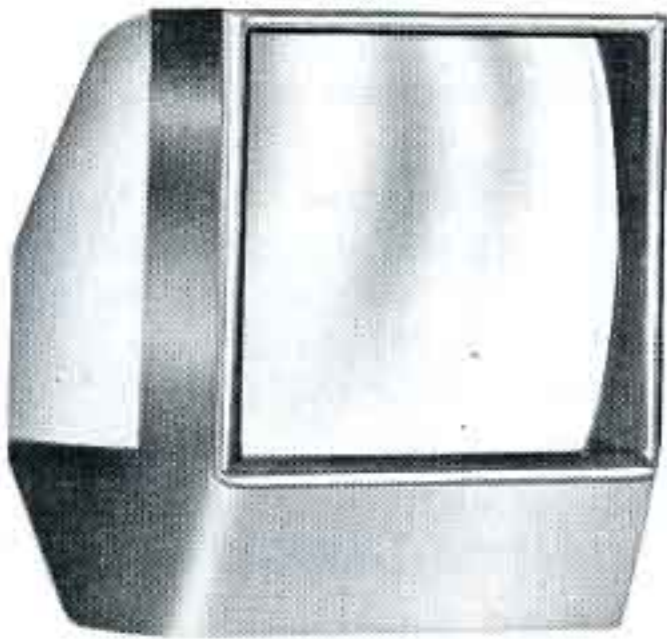

Betta-Vue Illuminated Hand Viewer

Takes all 35mm Slides, also half-frame and Super Slides. Shaped like a miniature TV set. Comfortable Magnifying Viewing Screen. Light goes on automatically when you insert the slide and goes out when you remove the slide. Battery operated, the Betta Vue Slide Viewer lets you carry it with you wherever you want to show off your slides.

Betta-Vue Slide Viewer \$2.95 + 35¢ Shipping.

Set of Batteries free with each Betta-Vue.

Buy several for small gifts:
Three for \$7.85 + 45¢. Six for \$13.75 + 65¢.

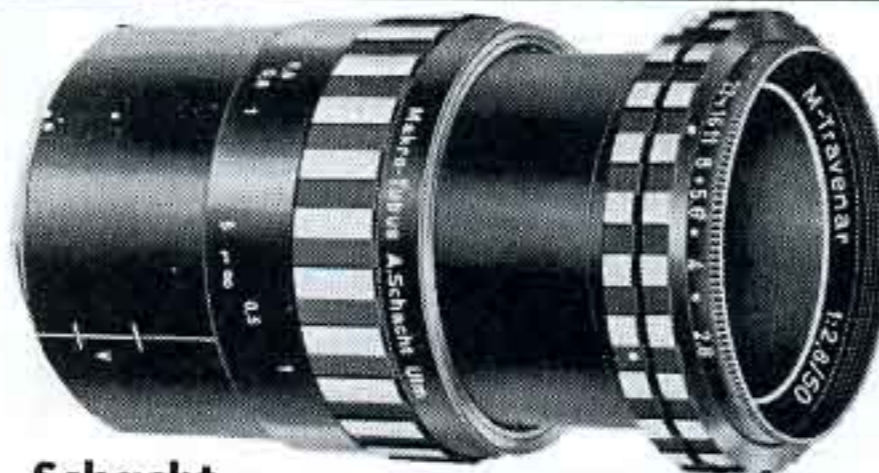

**Schacht
50mm F2.8 Macro Travenar**

Focuses from Infinity to 1:1 and higher magnification. Comes with removable double helix macro focusing tube. Self-calculating Exposure Factor Index. Ultra-sharp Tessar Formula. Optical part removable for use in bellows.

Stock No. 21673

Reduced to 49⁹⁵ Case 4.80 Postage 1.25

Ultra Sharp
Enlargements
with the new



Micro-Print

A precision instrument designed for the professional photographer but now priced for the amateur. Works like a microscope: You actually focus on the microscopic grain of the film.

If you make your own enlargements you cannot do without this instrument.

Micro-Print
Enlarging Magnifier
Stock No. C-21751

4⁹⁵ + 95¢ Postage



Slide Duplicator

Use it with Extension Tubes and your normal lens. Fits into your Series VII Filter Adapter. Slip slide into special holder. Diffusion glass prevents hot spot. Use any light source, even daylight. Helical Focusing Mount permits exact positioning of slide for correct focus. Use it to make duplicates of all your good slides. Also ideal for making black-and-white negatives from color slides.

Series VII
Slide Duplicator
Stock No.
21705

12⁵⁰ +75¢ Postage



Seymour's Steady Trip

the new combination Flashgun Bracket, Grip, and Remote Shutter Release. Ingenious collapsible design takes up very little room when not in use. For all flash and strobe units. Puts Flash in ideal position for natural-looking pictures. Comes in 2 Models.

Steady Trip
with fixed "shoe"
Stock No. 21640

395

+ 25¢ postage

Flip Trip
with ball joint swivel head
Stock No. 21641

595

+ 25¢ postage

They're all my Babies



Otto's Column

Otto symbolizes the personal interest, the professional pride, the high skill and the professional knowledge of Seymour's Exakta Service. Here's what he has to say:

I haven't been able to figure out why everybody seems to wait till about two weeks before his vacation to have his camera serviced. Why don't you nice people send me your cameras on a nice even year-round pace to help me keep everybody busy all the time: no thumb twiddling early in the year and no hectic overtime "peak" season just before Summer vacation time.

Well, I guess I can't change the habits of our customers. Nevertheless, I have to keep everybody busy in the Werkstatt ("Lab" to you). The Boss (Mr. Seymour, to you) had one of his brilliant ideas. "Otto, said he, "let's use the slack time to rebuild a whole bunch of trade-in cameras in the slack season." Well, I knew what he meant: Keep everybody busy and use the thumb-twiddling time productively. And he also meant that this way, a lot of cameras can be rebuilt, leisurely and without the pressure of rush jobs. And - (and I guess this is the most important point for you, My Dear Readers) he can sell the rebuilt cameras at a lower price. You pay less and you get more!

"Well, Boss, sez I (and I want to make it quite clear that I do NOT say "Vell" as I have been accused, although I must confess that occasionally I refer to the VXIIa as the "Wee Eggs" IIa. Anyway, what I said to the Boss was:) "You are going to lower the price on the rebuilt cameras, aren't you?" "None of your business what we sell them for" sez he. "Just see that they are being rebuilt to factory standards!" What he meant was "to Otto standards." I can read his mind like an open book.

Well, They're All My Babies, and I am seeing to it that they are being rebuilt to Otto standards. Wonder at what price he is going to sell that rebuilt Wee Eggs IIa, shucks, I mean VXIIa.

Till next time,

*Your Exakta Pamperer,
Otto.*

A Note from the "Boss" to Otto:

O.K., Otto, Now you know:

Otto-pampered, completely rebuilt and fully guaranteed EXAKTA VXIIA BODY, less lens and finder \$39.85 + 1.95. Pampered like Wee Eggs. One Year Guarantee on Labor and Parts.

Free Estimates on Exakta Repairs

Occasionally we receive a letter asking us for an estimate of repair charges. Obviously, we must see the camera first, open it up and determine what is needed in terms of parts and labor. There is no charge for this service (other than return shipping charges) and the decision is entirely yours whether you want us to go ahead with the repair or not.

Repair work is mostly labor and you are charged on a time basis. Our technicians don't have to fumble and waste time. They service Exaktas all day long - and nothing but Exaktas. They don't waste their time and your money! They are experts in their field. They do the work fast, they do it right, and they save you money.

We maintain a parts inventory of more than three thousand parts, including scarce parts and factory assembled sub-assemblies. We have special tools (without which you cannot service Exaktas) and we have instruments and test equipment (without which you cannot check shutter speeds, synchronization, alignment of the optical axis, or focus coordination!)

Our Service prices are the lowest at which satisfaction can be guaranteed.

For a free Service Estimate, do this: Pack your camera in a corrugated box, well protected by crumpled newspaper all around the camera. Attach a tag to the camera itself, giving your full name and address and describing briefly but clearly what ails the camera. Mark the tag: "Estimate Only." Mail the package by insured parcel post to: Seymour's-Exakta, Service Department, 350 West 31 Street, New York, N. Y. 10001.

We'll do the rest.

Budget Conscious?

Consider a Seymour-Rebuilt Exakta!

Fine Otto-pampered specimens, all rebuilt to Otto Standards. Every Seymour-Rebuilt Exakta carries an unconditional guarantee. No "fine print": One Year Guarantee on Labor and Parts. Period. Same Guarantee as new cameras. Period.

Seymour-Rebuilt Exakta VXIIa:-

Body, less lens and finder \$39.95 + 1.95 Shipping Charges.

Complete Camera: with Prism, MicroGrid

with fully automatic Meyer Optik F2.8 \$58.50 + 1.95

with fully automatic Jena Tessar F2.8 \$64.50 + 1.95

with fully automatic Jena Pancolar F/2 \$77.50 + 1.95

Slightly used Case \$5.95. Brand new Case \$7.85

SEYMOUR'S - EXAKTA

The World's Only *Exclusive* Exakta Dealer

350 W 31 St., New York, N. Y. 10001

Exakta Specialists for over 20 Years



New! Hot Accessory Shoe Conversion Assembly.

Convert your Exakta for flash and strobe units which require a "hot" shoe. Slides into your regular accessory shoe. Plugs into flash or strobe outlet of camera and supplies synch current directly to your flash. Regular Accessory Shoe (top or bottom model) also needed.

Hot Shoe Conversion Assembly \$2.85 + 15¢



New! PCTwin Outlet Converter.

Now, for the first time, you can fire two flash or strobe units simultaneously without the twin hot bracket. Professionals use two or more flash units to eliminate ugly shadows and to spread the light more evenly. They use multiple lights for close-ups, table tops, copying, etc. Now you can fire two or more lights without costly slave units, electronic trippers, or solenoids. Plug the PC Twin into the camera and the lights into the PC Twin. Can be used in Multiple Set-ups for 3, 4, or more lights. Sold only in sets of 2.

2 PC Twins \$1.85 + 15¢



New! All Metal Slide Sorter

A new idea in slide sorting. Slides sit on special metal rails and are easily moved around. Cannot slide or fall off. Arrange them and rearrange them for the proper projection sequence. You can select your best slides for projection because you see them all at the same time. An inexpensive yet indispensable accessory. Buy several for yourself and more as welcome gifts.

Metal Slide Sorter \$3.95 + 55¢
3 for \$10.75 + 65¢
6 for \$18.95 + 95¢



New! New DeLuxe Model Twin Cable Release Assembly.

Newly designed Double Cable Tripping Unit to retain the automatic feature of your lenses on bellows, tubes, etc. Easily adjusts to "throw" of different lenses.

DeLuxe Model Twin Cable Release Assembly \$7.75 + 25¢

New! Accessory Shoe for Permanent Mounting.

Attaches to ANYTHING by means of two screws. Attach it to the camera, make your own flash brackets, etc. Unlimited uses. Sold only in sets of 3.

3 Permanent Mount Shoes \$1.85 + 15¢



Automatic Extension Tubes for Exakta.

Set consists of 3 self-contained tubes. All three have the male and the female Exakta Bayonet. Each tube can be used independently by itself or in any combination. Rods couple to automatic lens and shutter release of camera and your automatic lenses remain automatic for close-up work.

Automatic Extension Tube Set for Exakta \$12.95 + 25¢



Reloadable Cassettes

This new German Cassette has screw top. Stock up at these low prices:

10 for \$ 3.50 + 35¢
25 for \$ 6.95 + 45¢
100 for \$24.50 + 65¢



New! Flat Camera Brush.

Indispensable for eliminating dust inside your camera, on your fine lenses and other equipment. Finest Camelshair.

Flat Camera Brush \$1.85 + 15¢



New! German Precision Calipers

Measure Lens Thread Diameters, etc. These calipers measure inside diameter, outside diameter, depth. Precision made in Germany.

Precision Calipers \$2.85 + 15¢



New! Accessory Shoe for BOTTOM of Camera.

The new BTL Systems pose a problem: the regular accessory shoe can no longer be used. Who has solved the problem? Seymour's-Exakta, of course! We have devised an Accessory Shoe which attaches to the BOTTOM of the Camera!

Bottom Accessory Shoe \$1.85 + 15¢



New! Roller Squeegee.

New heavy duty model. For flawless high-gloss finish of ferrotyped prints. 5 inches wide.

Roller Squeegee \$2.45 + 25¢



New! German Shoulder Pad.

Prevents camera strap from sliding off your shoulder. Leather top, rubber friction-hold bottom. Also prevents strap from hurting your shoulder. Sold only in sets of 3.

3 Shoulder Pads \$1.85 + 15¢



New! Braided Leather Neckstrap

Has Safety Catches. Holds camera safely and securely. Elegant. Supple. Pleasant to wear. No chafing.

Braided Neckstrap \$2.85 + 15¢



New! Swivel Brush.

Extra wide. Adjust angle of handle and get at difficult-to-reach parts of cameras, lenses, projectors, etc. First Quality Pure Camelshair.

Swivel Brush \$2.45 + 15¢



New! German Precision Screwdriver Set.

If you have to make quick adjustments on lenses, etc. use these precision tools. Tempered steel Blades. Four different sizes plus sure-grip handle. Fits even tiny screws. Cuts your cost of maintenance. Saves its cost the first time you use it.

Screwdriver Set \$1.85 + 15¢



Exakta Extension Tubes

Set consists of 5 parts: Male Exakta Bayonet, Female Exakta Bayonet, one tube each of 30mm, 15mm, and 5mm length.

Original Ihagee, Set \$11.95 + 35¢
Budget Set \$7.65 + 35¢



Two-in-One Extender

5mm total extension. Bridges gap between focusing range of lens with and without tubes. Has both the male and the female Exakta Bayonet machined INTO EACH OTHER. Very ingenious and effective.

Two-in-One Adapter \$8.95 + 25¢



Pneumatic Air Cable

Twenty feet remote control Air Release. Neoprene Tubing is impervious to heat, humidity. Comes rolled up on roller. Has hand bulb, air cylinder which activates the tripper.

Pneumatic Cable \$5.95 + 25¢

Short Air Cable

Serves best to eliminate camera shake because the air tubing does not transmit vibrations. 40 inches long. No roller but otherwise similar to 20-foot model.

40-Inch Air Cable \$4.95 + 25¢



Blower Brush

Hand Bulb, metal sheathed extending camelshair brush which retracts into body of bulb. Hinged dust cover to protect hair from dust. Gentle air stream loosens dust particles. Bristles brush them away. An absolute Must for delicate glass surfaces.

Blow Brush \$1.95 + 25¢

"Shortie" Cable Release

Six inches long. Cloth Covered.

Six-Inch Cable, Pak of four \$1.95 + 15¢

Vinyl Cable Release

Twenty inches long, professional type, has butterfly handgrip, locking device.

Vinyl Cable \$2.95 + 25¢



Rubber Sunshades

A new design which permits folding the sunshade back over the lens when not in use. Finest quality and fully as effective as the metal shades. Comes in Ser. VII and in mm sizes. State sizes needed.

Rubber Lens Shade \$4.50 + 25¢



Betta Vue Illuminated Hand Viewer

Takes all 35mm slides, also half frame and super slides. Shaped like a miniature TV Set. Light goes on automatically when you insert the slide and goes out when you remove the slide. Battery operated, the Betta Vue goes with you wherever you want to show off your slides. Set of batteries free.

Betta Vue Slide Viewer \$2.95 + 35¢



Metal Lens Caps, Screw-in

These come in Ser. VII or custom sizes

\$1.95 + 15¢. Three for \$4.95 + 25¢

Body Dust Cap for Exakta Body Bayonets into lens mount to protect the mirror and the shutter when you carry the body without lens.

\$1.95 + 15¢. Three for \$4.95 + 25¢

Rear Lens Cap, Bayonet Fitting. Dustproof. \$1.95 + 15¢. Three for \$4.95 + 25¢



Exakta Accessory Shoe

fits on top of prism (not for BTL)

Original Ihagee \$3.95 + 25¢

Independent Make \$1.95 + 15¢



Eyecup for Prism

swivels for horizontal or vertical shots. Has Retaining Ring for Prescription Lens.

Original Ihagee \$5.50 + 25¢



Giant Release Knob

Also called Giant Release Button. Allows fumble-free soft release of the shutter. A great help for rock-steady handheld pictures.

Giant Button \$1.95 + 15¢



Exakta Rewind Handle

for Models VX and VXIIa. Keeps Rewind Clutch Depressed. Makes rewinding very easy. Not needed on models with built-in rewind handle (VXIIB and later).

Rewind Handle \$2.85 + 15¢



Chrome Neckchain

Beautiful Chrome snakechain. Locking lugs. Round: does not cut into your neck.

Chrome Neckchain \$3.25 + 15¢

Leather Neckstrap

Flat Leather. Locks.

Leather Neckstrap \$1.95 + 15¢

Braided Leather Neckstrap

Beautiful braided leather. Round to protect your neck or shoulder. Extra heavy-duty locking lugs.

Braided Leather Strap \$2.95 + 15¢



Control the Speed of your Film with a

NEUTRAL DENSITY FILTER

At times it becomes important to increase the exposure WITHOUT stopping down the lens. The Neutral Density Filter adjusts the film speed to your needs. It does NOT change or alter the colors.

Neutral Density Filter

Series VII \$5.59 + 25¢

Soft Focus Disc.

Did you ever hate your best lenses because they revealed every tiny wrinkle in your portraits? Did you ever wish for a soft rendition of a beautiful landscape? Of course you did! Here is the solution: the new Soft Focus "Filter." It softens harsh lines and harsh light. Try one!

Soft Focus Disc, Ser. VII \$5.95 + 25¢

Grid Filter Disc.

Puts tiny sparkling "stars" on every light in your pictures. Adds romantic sparkle to otherwise dull shots. Especially dramatic in shots "against the light." Equally effective for color and black-and-white. Try one!

Grid Filter Disc, Ser. VII \$5.95 + 25¢

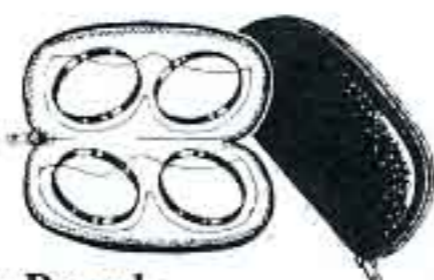

Filter Pouch

This beautifully designed Filter Pouch protects your delicate filters from dust and scratches. Four filters are in full view. Filter Pouch has smooth zipper, clear transparent "windows."

Zippered Filter Pouch \$1.95 + 25¢



Plus Ten

Auxiliary Close-Up Lens for ultra close-up work. High Quality coated optical lens. No exposure increase. Series VII Drop-in mount. Requires Filter Adapter.

Ser. VII Plus Ten Lens \$4.95 + 25¢

Combination Close-Up Set

Builds up from +1 to +6.

The Set consists of 3 high quality coated optical lenses in threaded mounts. Use them singly or in combination: they screw into each other. Unbroken Power Range from +1 to +6. Available in Series VII or in 49mm Thread Size. State preference. Leather Case included at no extra charge.

Combination Close-Up Set

\$12.50 + 35¢



Series VII Filter Adapters

Use with Series VII Filters, Grid Discs, Soft Focus Discs, etc. Available for lenses with front diameter of 46mm, 49mm, 52mm, 54mm, 55mm, 58mm.

Ser. VII Filter Adapter \$4.50 + 25¢

49mm Series Six Adapter

Do you want to use inexpensive Ser. VI filters and accessories on your lenses with 49mm diameter? This special "step-down" adapter makes it possible.

Ser. VI/49mm Adapter \$3.95 + 25¢



Sunshades

Series VII, fits adapter \$4.95 + 25¢
49mm, fits lens, \$4.95 + 25¢



Reloadable Cassettes

Load your own film cassettes at a fraction of the cost of factory loaded cartridges. Use the cartridges over and over. Top unscrews for easy assembly. Made in West Germany.

Cassettes, Pak of Ten \$3.50 + 25¢
25 for \$6.95 + 35¢
100 for \$24.50 + 45¢

Miniature Tool Kit

Make simple emergency repairs or adjustment on location. Consists of tiny hammer, small screwdriver, small Phillips screwdriver, piercer or punch, and a small auger to start screws in wood. All tools fit a small handle which locks them securely in a tiny precision chuck.

Miniature Tool Set \$1.95 + 35¢



Eyelevel Finder

Original Ihagee PentaPrism without Focusing Insert \$14.50 + 65¢
with Fresnel/MicroGrid \$18.50 + 65¢

Waistlevel Finder

Original Ihagee Hooded Reflex Finder with Magnifier for critical focusing without Focusing Insert \$11.95 + 65¢
with Fresnel/MicroGrid \$16.50 + 65¢

Focusing Insert

Combination Fresnel Viewing Screen with MicroGrid Rangefinder and finegrain Groundglass Ring, Original Ihagee \$7.50 + 35¢
Independent Make, \$5.95 + 35¢
Groundglass with MicroGrid \$4.95 + 35¢



Bouncelight Swivel Joint

Converts any flash or strobe into a bounce gun. Also very useful for aiming the flash. Omni-directional. Chrome-on-brass construction.

Bounce Swivel \$3.95 + 25¢



Reverse Adapters

Indispensable for ultra close-up work with normal lenses. These come in Series VII with Exakta Bayonet or in 49mm with Exakta Bayonet. State preference.

Reverse Adapter \$3.95 + 25¢



Twin Flash Bracket

Mounts and fires two flashguns or strobes. Internally wired. Plugs into flash outlet of camera and the two guns plug into the outlets of the bracket. Two flash or strobe guns soften the light, eliminate harsh shadows, flatter the subject and, best of all, double the light.

Twin Flash Bracket \$4.95 + 45¢

Micro-Print

Do you do your own enlarging? Here is an instrument which makes it impossible to get out-of-focus enlargements. It works like a microscope: You place it on the easel of your enlarger, turn on the enlarger and actually focus on the microscopically small grain of the film emulsion. Focus is not affected by the sharpness of the negative.

MicroPrint \$4.95 + 95¢

SEYMOUR'S
The Exakta Specialists

SEYMOUR'S - EXAKTA

The World's Only *Exclusive Exakta Dealer*

350 W 31 St., New York, N. Y. 10001

Exakta Specialists for over 20 Years

Net Price List

EXAKTA CAMERAS

Latest 1970 Exakta VX-1000TL, Original Ihagee PentaPrism, Combination Fresnel Viewing Screen and MicroGrid Focusing Aid, fully automatic genuine Jena 50mm F2.8 Tessar Lens, \$87.50 plus \$7.85 for the case and \$1.95 Shipping Charges.

Same, but with F2.8 fully automatic Meyer Optik Domiplan, \$79.50 plus \$7.85 for the case and \$1.95 Shipping Charges.

Same, but with F/2 fully automatic genuine Jena Pancolar \$99.50 plus \$7.85 for the case and \$1.95 Shipping Charges.

Latest 1970 Exakta VX-1000TL/BTL, with New Model Travemat Behind-the-Lens Metering Prism with Combination Fresnel Viewing Screen and MicroGrid Focusing Aid with F2.8 fully automatic Meyer Optik Domiplan \$109.50 plus \$17.85 for the special Case with Extra High Top and \$1.95 Shipping Charges.

Same, but with fully automatic F2.8 genuine Jena Tessar \$117.50 plus \$17.85 for the case and \$1.95 Shipping Charges.

Same, but with fully automatic F/2 genuine Jena Pancolar \$129.50 plus \$17.85 for the case and \$1.95 Shipping Charges.

Cases come factory packed with cameras. Purchase of case is mandatory.

Latest 1970 Exakta VX-500 with Model C Hooded Reflex Finder with Magnifier for critical focusing, with captive finegrain groundglass with F2.8 fully automatic Meyer Optik Domiplan \$49.95 plus \$7.85 for the case and \$1.95 Shipping Charges.

Same, but with F2.8 fully automatic genuine Jena Tessar \$57.95 plus \$7.85 for the case and \$1.95 Shipping Charges.

Same, but with F/2 fully automatic genuine Jena Pancolar \$69.95 plus \$7.85 for the case and \$1.95 Shipping Charges.

Exakta Bodies, less lens and finder:

Latest 1970 Exakta VX-1000TL \$64.50 + 1.95 Shipping Chgs.

Latest 1970 Exakta VX-500 \$39.95 + 1.95 Shipping Chgs.

Case, optional \$7.85

Exakta Bodies, with original Ihagee PentaPrism and Combination Fresnel Viewing Screen and MicroGrid Focusing Aid:

VX-1000TL \$78.50 + 1.95 Shipping Charges

VX-500 \$54.50 + 1.95 Shipping Charges

Case, optional, \$7.85

Exakta BTL Bodies, with New Model Travemat Behind-the-Lens Metering Prism, without lens:

VX-1000TL/BTL \$108.50 + 1.95 Shipping Charges

VX-500 BTL 84.50 + 1.95 Shipping Charges

Special Case with Extra High Top \$17.85 (optional)

STANDARD FOCAL LENGTH LENSES

50mm F2.8 fully automatic Meyer Optik Domiplan \$19.85+95¢

50mm F2.8 fully automatic genuine Jena Tessar \$27.50+95¢

50mm F/2 fully automatic genuine Jena Pancolar \$39.95+95¢

VIEW FINDERS

Hooded Reflex Finder, Model C

with captive finegrain groundglass \$ 8.95 + 65¢

Hooded Reflex Finder, Model N,

without Insert \$11.95 + 65¢

with finegrain groundglass \$14.95 + 65¢

with Combination Fresnel Screen and MicroGrid \$16.50 + 65¢

Eyelevel PentaPrism, Original Ihagee

without Insert \$14.50 + 65¢

with Combination Fresnel Screen and MicroGrid \$18.50 + 65¢

New Model Travemat BTL System with MicroGrid \$49.50 + 95¢

FOCUSING SCREEN INSERTS

These Screens fit the PentaPrism, the new Model Travemat, the Examat, and the Model N Waistlevel Finder:

Finegrain Groundglass \$3.95 + 35¢

Combination Fresnel Screen/MicroGrid, best \$7.50 + 35¢

Groundglass with MicroGrid \$4.95 + 35¢

Split Image Rangefinder Insert \$6.95 + 35¢

CAMERA CASES

Standard Case, Non-detachable front \$ 7.85 + 95¢

Black Case, detachable front, most popular case . 9.85 + 95¢

Brown DeLuxe Case, detachable frt., Metal Trim 14.95 + 95¢

Black DeLuxe Case with Extra High Top, with

detachable front (takes camera with BTL Meter) 17.85 + 95¢

Special Case with Extra High Top and extra large

front (takes camera with BTL Meter and Macro

Lens) 19.95 + 95¢

Shipping Charges

Some customers write and ask whether the Shipping Charges shown in our listings are just for the Postage: "How much do I have to add for handling, packing, shipping containers, insurance, etc.?" You don't have to add anything. The amount shown under "Shipping Charges" includes everything.

WIDE ANGLE LENSES

| | |
|--|--------------|
| 35mm F4.5 preset Meyer Optik Primagon | 19.95 + 95¢ |
| 35mm F3.5 preset Terragon | 19.95 + 95¢ |
| 28mm F2.8 preset Rokunar | 39.95 + 95¢ |
| 35mm F2.8 cocking automatic Schacht Travegon . | 39.95 + 95¢ |
| 35mm F2.8 fully automatic Rokunar | 59.50 + 1.25 |
| 35mm F3.5 fully automatic Steinheil Culmigon . . | 44.50 + 95¢ |
| 28mm F2.8 fully automatic Rokunar | 69.50 + 1.25 |
| 35mm F2.8 fully automatic Jena Macro Flektogon with self-compensating diaphragm | 89.50 + 1.25 |

TELEPHOTO LENSES from 85mm to 135mm

| | |
|---|---------------|
| 85mm F1.9 preset Super Coligon | 44.50 + 1.25 |
| 90mm F2.8 cocking automatic Schacht Travenar . | 39.95 + 95¢ |
| 100mm F3.5 fully automatic Steinheil Casrit . . . | 44.50 + 1.25 |
| 105mm F2.8 fully automatic Rokunar | 59.50 + 1.25 |
| 135mm F4.5 preset Schacht Travenon | 26.45 + 95¢ |
| 135mm F3.5 cocking automatic Schacht Travenar. | 44.25 + 95¢ |
| 135mm F3.5 fully automatic Schacht Travenar . . | 54.25 + 1.25 |
| 135mm F2.8 fully automatic Steinheil T/Quinar . | 89.50 + 1.25 |
| 135mm F2.8 fully automatic Rokunar | 69.50 + 1.25 |
| 135mm F/4 fully automatic Jena Sonnar | 79.50 + 1.25 |
| 135mm F2.8 fully automatic Steinheil Macro-S . | 159.50 + 1.25 |

TELEPHOTO LENSES, 150mm and longer

| | |
|--|---------------|
| 150mm F5.5 preset Meyer Optik Tele-Megor | 19.95 + 95¢ |
| 180mm F2.8 fully automatic genuine Jena Sonnar | 159.50 + 2.95 |
| 200 F4.5 preset Tele-Rokunar | 49.50 + 1.25 |
| 200mm F3.9 fully automatic Rokunar | 79.50 + 1.35 |
| 300mm F5.5 fully automatic Rokunar | 89.50 + 1.65 |
| 400mm F5.5 preset Meyer Optik Tele-Megor | 89.50 + 2.95 |
| 500mm F/8 preset Meyer Optik Orestonar | 179.50 + 3.85 |

ZOOM LENSES

| | |
|--|---------------|
| 55mm to 90 mm F5.6 preset Tamron | 59.50 + 1.25 |
| 85mm to 205mm F3.6 fully automatic Rokunar . | 139.50 + 1.95 |

MACRO and CLOSE-UP EQUIPMENT

Exakta Bellows

| | |
|---|-------------|
| Twin-Rod Models with geared Rack-and-Pinion Focus Model TW-5 with full 5-inch Extension | 17.95 + 95¢ |
| Model TW-7, Extra Long 7" (180mm) Extension . | 19.95 + 95¢ |
| Monorail Model with geared Rack-and-Pinion Focus Model MR-5, Full 5-inch Extension | 13.95 + 95¢ |
| Proxette Exakta Bellows, Original Ihagee Double-rod, Push-Pull, w/locking knob | 27.50 + 95¢ |

Extension Tubes

| | |
|---|--------------|
| 5-Part Set, Male and Female Bayonet, 5mm, 15mm, and 30 mm Original Ihagee Tube Set | 11.95 + 35¢ |
| Independent Make Tube Set | 7.65 + 35¢ |
| Automatic Tubes (automatic lenses remain automatic) 3-part set (each part has its own male bayonets) | 12.95 + 35¢ |
| Twin Cable Release, trips automatic lens and shutter, Budget Quality | 6.85 + 20¢ |
| New German Precision Model | 9.70 + 25¢ |
| Macrolite: Direct Reading Exposure Factor Screen. Use it in Prism or Model N Waistlevel Finder . . | 17.85 + 25¢ |
| Travemat BTL System, New Model, Gives you the correct exposure for close-up work because it sees the exact amount of light that will reach the film. No calculation, no compensation, regardless of extension | 49.50 + 1.35 |

Close-up Lenses

| | |
|--|-------------|
| Set of 3, consisting of +1, +2, +3. Builds up to +4, +5, +6. High quality Optical Lenses, coated, in metal screw-in mount: Series VII (requires Filter Adapter) | 12.50 + 45¢ |
| 49mm (Screws directly into Pancolar, Tessar). . | 12.50 + 45¢ |
| Series VII Drop-in Plus-Ten Close-Up Lens for ultra close-up work (requires Filter Adapter) . . | 5.95 + 25¢ |

Short-Barrel Lenses, for use in Bellows:

| | |
|---|-------------|
| 100mm F3.5 preset German Schacht Travegar . . . | 19.95 + 95¢ |
| 135mm F4.5 preset German Schacht Travenon . . | 19.95 + 95¢ |

Macro Lenses:

| | |
|---|---------------|
| 35mm F2.8 gen. Jena Macro Flektogon with self- compensating diaphragm, fully automatic | 89.50 + 1.25 |
| 135mm F2.8 fully automatic Steinheil Macro-S . | 159.50 + 1.25 |

Special Ultra Close-Up Lens: 22mm F2.8 Macro

| | |
|---|-------------|
| Doryt. Fix Focus (fixed at 1½ times life size). Complete with Exakta Bayonet Mount | 12.50 + 65¢ |
|---|-------------|

CAMERA CASES, LENS CASES, GADGET BAGS, ETC.

Exakta Ever-Ready Cases:

| | |
|---|-------------|
| Exakta Case, non-detachable front | 7.85 + 95¢ |
| Exakta Case, detachable front | 9.85 + 95¢ |
| Exakta Case, Metal Trim, detachable front | 14.50 + 95¢ |
| Exakta Case, extra high top (BTL Meter) | 17.85 + 95¢ |
| Exakta Case, extra large front (Macro Lens) | 17.85 + 95¢ |
| Exakta Case, X Hi Top and X large front | 19.85 + 95¢ |

Lens Cases:

| | |
|---|----------------|
| Hard Cases for Lenses up to 135mm | 4.95 + 65¢ |
| Cases for larger lenses, etc. | request prices |

Lens Pouches:

| | |
|---|------------|
| Small Velvet Lined Drawstring Pouch | 2.95 + 25¢ |
| Medium Size Velvet Lined Drawstring Pouch | 3.95 + 25¢ |
| Large Velvet Lined Drawstring Pouch | 4.95 + 25¢ |

Equipment Cases, Gadget Bags, etc.:

| | |
|---|--------------|
| Topgrain Cowhide Bag 12 x 10 x 6 | 29.95 + 1.65 |
| "SAFARI" Foam Fitted Attache Case | 19.95 + 1.65 |
| Old Model Foam Fitted Attache Case, Close-Out . | 11.95 + 1.65 |
| "STATUS" Pro Bag | 39.95 + 2.35 |
| "STATUS" Pro Bag, Super Size | 69.50 + 2.95 |

Miscellaneous:

| | |
|--|------------|
| Vinyl Accessory Bag, Close-Out, our choice | 2.00 + 35¢ |
| Filter Pouch, for 4 Filters in easy view | 1.95 + 25¢ |
| Case for Heliotron Perma Strobe | 3.95 + 35¢ |
| Neckchain, chrome Snakechain | 3.25 + 25¢ |
| Neckstrap, Leather, flat | 1.95 + 15¢ |
| Neckstrap, Leather, braided, round | 2.95 + 15¢ |
| Shoulder Pads, for camera case strap, Pak of 3 | 1.85 + 15¢ |
| Shoulder Pads, Jumbo Size, each | 1.85 + 25¢ |

FLASH EQUIPMENT:

| | |
|---|--------------|
| Heliotron Perma Power Strobe, with case | 33.90 + 1.25 |
| Fanfold BC Flashgun (for flash bulbs) | 6.95 + 65¢ |
| Fanfold BC Gun with "Bounce" Feature | 8.95 + 65¢ |
| Cube Gun with Battery (cubes not included) | 5.20 + 65¢ |
| Steady-Trip Flash Bracket | 3.95 + 25¢ |
| Flip-Trip Flash Bracket with Swivel | 5.95 + 35¢ |
| Accessory Shoe, Original Ihagee | 3.95 + 15¢ |
| Accessory Shoe, independent make | 1.95 + 15¢ |
| Accessory Shoe for Bottom of Camera | 1.85 + 15¢ |
| Grip-O-Matic Flash Bracket with Cable Tripper | 4.95 + 45¢ |
| Sky-High Flash Bracket with Extension Cord | 7.90 + 55¢ |
| Twin Flash Bracket, internally wired | 4.95 + 45¢ |
| Hot Shoe Conversion Assembly | 2.85 + 15¢ |
| PC Twin Outlet Converter, Pak of 2 | 1.85 + 15¢ |

EXPOSURE METERS:

| | |
|--|--------------|
| Travemat BTL System, New Model | 49.50 + 1.35 |
| Toshiba CdS Exposure Meter, w/battery & Case . . | 16.95 + 95¢ |

FILTERS, POLARIZERS, ETC.:

| | |
|--|----------------|
| Filters, 49mm Screw-in Size | 4.95 + 25¢ |
| Rotating Polarizers, 49mm Screw-in Size | 10.85 + 25¢ |
| Filters, Polarizers, other sizes | request prices |
| Grid Filter Disc, Series VII | 5.95 + 25¢ |
| Soft Focus Disc, Ser. VII | 5.95 + 25¢ |
| Neutral Density Filter, Ser. VII | 5.95 + 25¢ |
| Plus Ten Auxiliary Close-Up Lens, Ser. VII | 4.95 + 25¢ |
| Close-Up Lens Set, 3 Lenses build up from +1 to +6 | |
| 49mm Screw-in Size, with Leather Case | 11.95 + 35¢ |
| Series VII (threaded), with Leather Case | 11.95 + 35¢ |
| Filter Pouch, takes 4 Filters in full view | 1.95 + 25¢ |

FILTER ADAPTERS, SHADES, ETC.:

| | |
|---|------------|
| Ser. VII Filter Adapters, 46mm to 58mm | 4.50 + 25¢ |
| Ser. VII Sunshade, to fit above adapters | 4.95 + 25¢ |
| Sunshades, Screw-in, 46mm to 55mm | 4.95 + 25¢ |
| Sunshades, Screw-in, 58mm | 5.95 + 25¢ |
| Sunshades, Screw-in, 62mm | 6.95 + 35¢ |
| Rubber Sunshades, fold back over lens, Ser. VII | 4.95 + 25¢ |
| Rubber Sunshades, Screw-in, 46mm to 55mm | 4.95 + 25¢ |
| Inst-A-Dapter, converts one mm size to another | |
| any combination male/female 49,52,54,55mm | 2.75 + 25¢ |
| Metal Lenscaps, Screw-in, Series VII | 1.95 + 25¢ |
| Metal Lenscaps, Screw-in, mm sizes, state size | 1.95 + 25¢ |

15 Days Money Back
on ANY item
in this folder

MISCELLANEOUS EQUIPMENT:

| | |
|--|------------|
| Master Showman Projection Pointer | 6.95 + 45¢ |
| All Metal Slide Sorter | 3.95 + 55¢ |
| Micro-Print, Focusing Magnifier for Enlarger | 4.95 + 95¢ |
| Blower Brush, retractable, rubber bulb | 1.95 + 20¢ |
| Flat Camera and Lens Dust Brush, Camelshair | 1.85 + 15¢ |
| Swivel Brush, Camelshair | 2.45 + 15¢ |
| Calipers, German, measures diameter | 2.85 + 15¢ |
| Screwdriver Set, 4 different blades | 1.85 + 15¢ |
| Miniature Tool Kit | 1.95 + 25¢ |
| Pistol Grip with Cable Tripper | 5.95 + 95¢ |
| Reloadable Cassettes, Pak of 10 | 3.50 + 25¢ |
| Pneumatic Shutter Release, 20 feet | 5.95 + 25¢ |
| Pneumatic Shutter Release, 40 inches | 4.95 + 25¢ |
| Twin Cable Release Assembly, Budget Model | 6.85 + 25¢ |
| Twin Cable Release, New German Precision Model | 9.70 + 25¢ |
| Leather Neckstrap, flat | 1.95 + 15¢ |
| Leather Neckstrap, braided, round | 2.95 + 15¢ |
| Chrome Neckchain, snakechain | 3.25 + 15¢ |
| Exakta Rewind Handle for VX, VXIIa | 2.85 + 25¢ |
| T Mount Adapter for T-Mount Lenses (Exakta) | 4.95 + 25¢ |
| Hot Flash Shoe, with cord | 2.85 + 15¢ |
| Cold Flash Shoe with PC Outlet | 2.45 + 15¢ |
| Dustcap for Exakta Camera Body | 1.95 + 15¢ |
| Rear Lens Cap, Bayonet for Exakta Lenses | 1.95 + 15¢ |
| Screw-in Lenscaps, Series VII or custom size | 1.95 + 15¢ |
| Permanent Mount Accessory Shoe, Pak of 3 | 1.85 + 15¢ |

SEYMOUR'S-EXAKTA
 350 West 31 Street, New York, N. Y. 10001
Exakta Specialists for over 20 years

Better Filters, Better Pictures!

It doesn't make sense to spend a good deal of money on a highly corrected lens, only to destroy the correction with a poorly made filter! Seymour's-Exakta lets you buy only the most critically selected plano-parallel filters, guaranteed to match the optical performance of the most highly corrected lens.

Huge turnover permits us to buy at very advantageous quantity prices. Satisfied with a small mark-up, we bring you these top quality filters at typical Seymour Prices.

Until last year we sold our Series VII Filters for \$5.95 each. About a year ago we dropped the price to \$4.50. The increased volume encouraged us to make larger commitments which led to better prices from the factory. Now we decided to shave the prices down to an irreducible minimum to make it possible for everybody (and we mean EVERYBODY!) to stock up on all the filters he wants. Look at this price:

Series VII coated
 Filters in sets of 4, each **3⁴⁹** (Singly 3.95)

Quality Filters at Incredibly Low Prices:

| | Single Filters | Set of 4 Filters | Rotating Polarizer | Neutral d. Grid Disc Soft Disc | Single Close-Up | Set of 3 Close-Up |
|--------------------|----------------|------------------|--------------------|--------------------------------|-----------------|-------------------|
| Series VII Drop-in | 3.95 | 13.95 | 9.85 | 5.95 | 4.50 | 11.95 |
| 49mm Screw-in | 4.95 | 15.95 | 10.85 | 6.95 | 4.95 | 11.95 |
| 46 and 52mm | 4.95 | 15.95 | 10.85 | 6.95 | 5.95 | 13.95 |
| 54 and 55mm | 5.45 | 17.95 | 11.85 | 8.95 | | |
| 58mm | 6.45 | 19.95 | 12.85 | 9.95 | | |
| 62mm | 6.95 | 21.95 | 13.85 | 12.50 | | |

Postage: 25¢ for Single Filters; 35¢ for Sets

| | | |
|---|-----------------------|------|
| b. Series VII Filter Adapters for Drop-in Filters | 4⁵⁰ | each |
| 46mm, 49mm, 52mm, 54mm, 55mm | | |
| Series VII Sunshades | 4⁹⁵ | each |
| Fits into any of the above adapters | | |
| 49mm Screw-in Shade | 4⁹⁵ | each |
| Fits directly into lens | | |

Sky-High Flash Bracket



This new Flash Accessory was invented by a news photographer who needed the high-angle light to flatter his subjects. For the first time he was able to eliminate the ghastly results of head-on flash. A high angle of light gives the appearance of natural daylight and eliminates the dreaded shadows caused by flash. Gone are the pasty faces, the staring eyes, the harsh contours usually associated with flash pictures. The Sky-High Flash Bracket, extends, telescopes, and folds flat for easy carrying. It attaches to your camera just like an ordinary flash bracket. On top it has a shoe to attach your flash or strobe. Since most flashguns have only a short cord, we recommend a flash extension cord for greatest versatility.

Sky-High Flash Bracket
 Extension Cord — \$1.95
\$5⁹⁵ +55¢ Shipp'g

Buried Treasures

Many New Items and many Terrific Buys are buried in the small print of this Issue.

Don't miss a single new item! Don't miss the juiciest bargains! Read Every Word!

NEW 35mm F2.8

**Jena
Macro
Flektogon**



89⁵⁰ Shipping 1.25
Case \$4.95. Filter Adapter \$4.50.

Steinheil fully automatic 35mm F3.5 Auto Culmigon



35mm F3.5 Steinheil Auto Culmigon
Fully Automatic Diaphragm (3.5 to 16)
Focuses to 2½ ft. Non-glare Finish.
Auto/Manual Switch. In-Line Release.
Takes 49mm Accessories. Ultra Compact.
Famous Steinheil Quality.
Seymour-priced at only **44⁵⁰**
Case 3.95 Shipping 95¢
Orig. Steinheil Shade 3.95

GIANT Release Button

Convenient, Fumble-Free, Soft Release. Eliminates
Camera Shake. Trip the shutter even with mittens!
Precisely machined. All Metal.
GIANT RELEASE BUTTON \$1.25

Fifteen Days Money Back

on Any Stock Item

YOUR HELP, PLEASE!

If the address on this Newsletter is incorrect, please drop us a line, giving BOTH the incorrect AND the correct versions, both with ZIP numbers. Please be sure to give both the incorrect and the correct ZIP, especially if you've moved. We try very hard to get it right!

If you are no longer interested in our mailings, please tell us to delete your name from our Distribution List.

If you receive more than one copy, please tell us which address to keep on the list and which to delete.

And PLEASE remember:- old addresses, incorrect addresses and correct addresses: ALWAYS INCLUDE ALL ZIP NUMBERS.

Thank you very much!

SEYMOUR'S-EXAKTA
350 W 31 St., New York, N. Y. 10001
Exakta Specialists for over 20 Years

BULK RATE
U. S. POSTAGE
PAID
Permit No. 50
Brooklyn, N. Y.