

# Exakta News

Christmas Issue 1970

Published by

**SEYMOUR'S-EXAKTA**

350 W 31 St., New York, N. Y. 10001

Exakta Specialists for over 20 Years



**SEYMOUR'S-EXAKTA**

presents

**RTL**

by Exakta

In 1937, more than a third of a century ago, Exakta gave the World the first 35mm Single Lens Reflex Camera. Exakta engineered, developed, "invented" the 35mm SLR thirty-four years ago! During these years, Exakta refined and improved model after model but did not change its basic design concept.

The time has come to re-design ("Modernize," if you will) the World's First SLR. Today, after 34 years, Exakta presents a radically different, thoroughly modern and far-ahead-of-its-time, entirely new camera, the RTL.

We let the Engineers speak:

All the famous Exakta Features have been retained in the RTL: Interchangeable Finders (Prism, Waistlevel, Through-the-Lens Metering Prism), Bayonet-mounted interchangeable lenses, 1/1000 sec. Shutter Speed, Delayed Action Selftimer, Instant-Return Mirror, etc., but many Exakta "First" have been added:

1. New "TTL" Lightmeter is COUPLED with the SHUTTER SPEEDS.
2. New Through-the-Lens Meter (TTL) lets you determine

correct exposure with the lens wide open OR stopped down.

3. Strobe Synchronization up to 1/125 sec.
4. New ALL METAL Focal Plane Shutter.
5. Automatic Film Threading.
6. Internal OR EXTERNAL automatic diaphragm activators permit use of the new automatic lenses with internal automatic release OR older automatic lenses with external automatic release.
7. Right hand AND left hand Shutter Releases.
8. Automatic Film Counter sets itself to zero when you "load" the RTL.
9. Ultra Fast Rapid Wind (15 Degrees!) for quick-sequence shots.
10. Click-in Rewind Release Knob; Built-in Rewind Crank; Hinged, Self Closing Back; and a great many engineering improvements, based on latest developments in science, metallurgy, mechanics and optics.

Seymour's-Exakta brings you the new Exakta RTL, complete with the new shutter-coupled TTL Exposure Metering Prism, with F1.8 fully automatic Oreston Lens with internal automatic release, for \$199.50 plus \$17.85 for the Case with Extra High Top (mandatory) and \$1.95 Shipping Charges.

# SEYMOUR'S - EXAKTA

The World's Only *Exclusive* Exakta Dealer

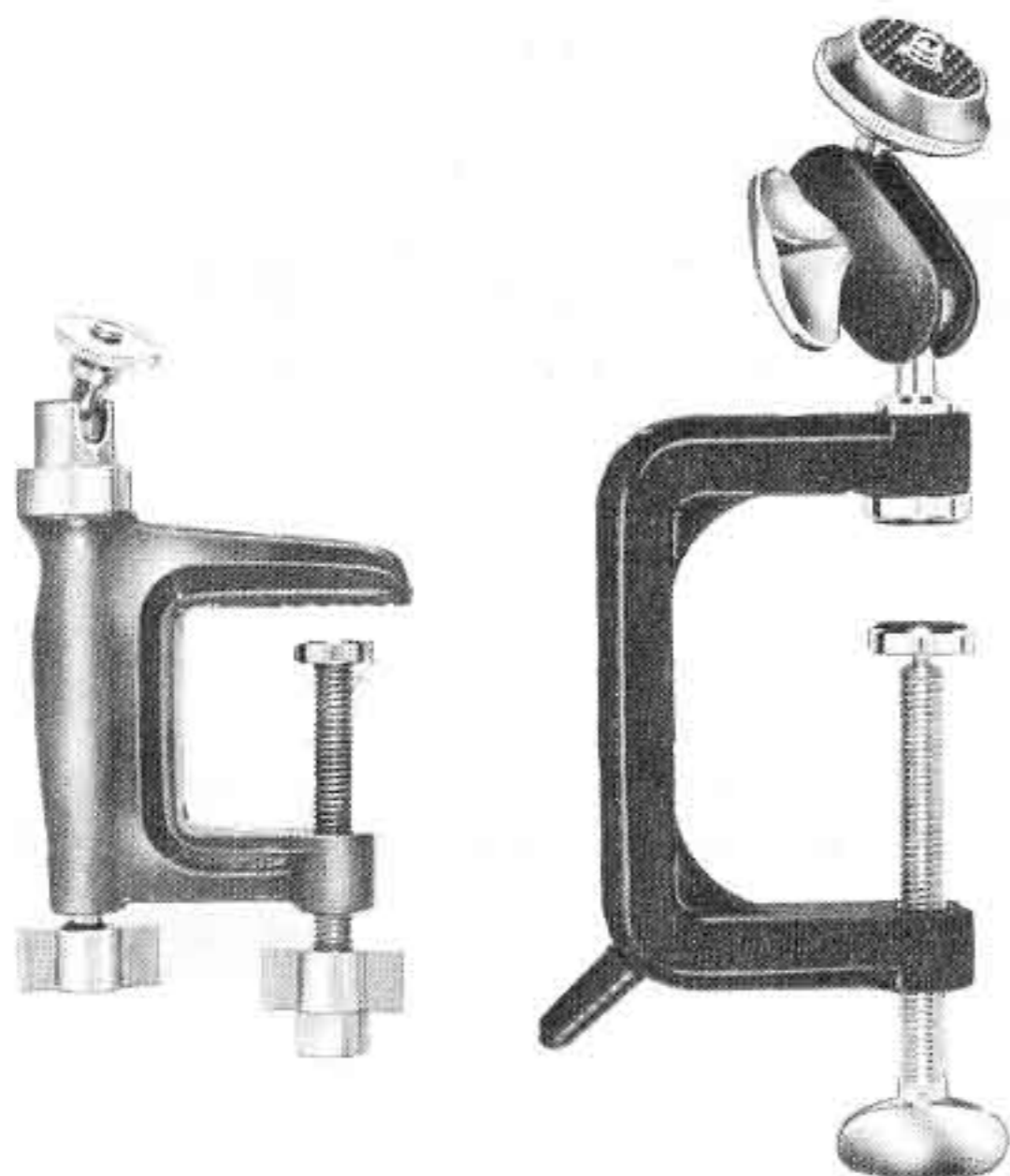

## Two New Models of the Popular Clamp Pod.

Clamp Pods have been described as "Pocket Tripods." But they are much more versatile than a tripod. They attach to virtually ANYTHING, to a park bench, to a car window, to a table, to a chair back. An ingenious wood screw lets you attach the clamp pod even to a TREE! Both models come with Universal Swivel Joint. Order the simpler Clamp Pod or the elaborate Super Pod. Both are all metal.

Clamp Pod \$3.95 + 35¢ Shipping Charges.  
Super Pod \$5.95 + 45¢ Shipping Charges.

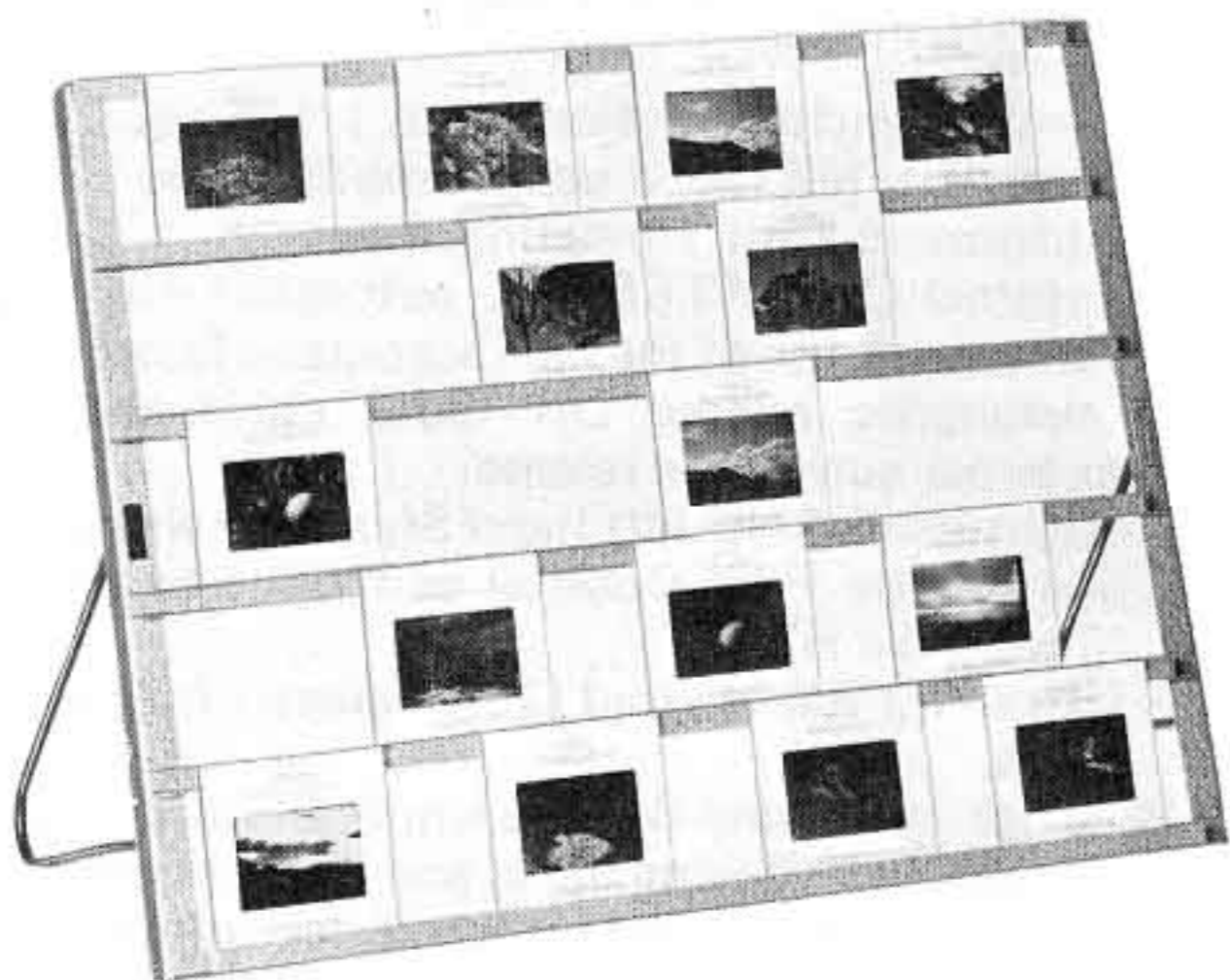

## All Metal Slide Sorter

A new idea in slide sorting. Slides drop into special metal rails and can easily be moved around. They cannot fall or slide off. You can easily arrange and re-arrange them for the most effective projection sequence or for any other purpose. It is easy to select the best slides for projection because all of the slides are in view at the same time. This new slide sorter is inexpensive yet it is indispensable for any 35mm camera enthusiast. Buy several for yourself and many more as welcome gifts.

All Metal Slide Sorter \$3.95 + 55¢ Shipping.  
3 for \$10.75 + 65¢. 6 for \$18.95 + 95¢.

# Exakta RTL

## Your Questions Anticipated

Question: Is the Exakta RTL available for immediate shipment?

Answer: We are fairly sure that the RTL will be ready for shipment by the time this Newsletter reaches you. Naturally, in the beginning the camera will be in short supply. All orders will be filled as quickly as possible in the same sequence as we receive them.

Q.: Is the body available separately?

A.: No. The Exakta RTL is sold only complete with Lens, TTL Prism, and Case.

Q.: Are trades of older Exaktas accepted?

A.: Yes, but only on complete cameras with Lens, TTL Prism and Case.

Q.: Can all lenses from older Exakta models be used in the RTL?

A.: Yes.

Q.: Can the "TTL" Metering Prism System be used in older Exakta Models?

A.: No.

Q.: Can Finders from older Exakta Models be used in the RTL?

A.: No.

Q.: Is there a Waistlevel Finder or a non-TTL Prism for the RTL?

A.: Not yet, but they will be available soon.



## A Windfall – just in Time for Christmas

Once again we can fill orders for Jena's Top-of-the-Line Lens, the fully automatic 50mm F/2 Jena Pancolar. The new model has the new automatic Depth-of-Field Indicator, two moving arrow pointers which automatically bracket the exact Depth of Field at any distance and at any F stop. Watch them move "magically" as you vary the F opening or the distance. A wonderful help, eliminating the guesswork what part of the foreground or background will be in sharp focus.

The optical and mechanical excellence of the Jena Pancolar has been written up so often that I don't have to repeat it. If it means anything to you, most of the color enlargements of my slides which are displayed in our showroom were taken with the Pancolar. Customers marvel at the color rendition, the sharpness, the balanced contrast of these slides. While I modestly acknowledge my customers' opinion that I can make the Exakta sing, I could not have done it without the help of my trusty Pancolar.

I honestly would like everybody to have a Pancolar. Even though prices are going up and up and the value of the dollar down and down, I will still fill your order for the Pancolar at the old low price of only \$39.95 + 95¢ Shipping Charges. And we will fill all orders with the new model with the automatic Depth-of-Field Indicator described above. Every lens brand new, of course, and still only \$39.95 + 95¢ Shipping Charges. Please send your order as soon as possible. Right now we have a good supply, but we'll probably run out before Christmas.

Fully automatic 50mm F/2 genuine Jena Pancolar, New Model with Automatic Depth-of-Field Indicator \$39.95 + 95¢ Shipping Charges.



## Exakta VX-1000TL

The new Exakta VX-1000TL is loaded with features. No matter how hard you look, you won't find another camera which comes even close in versatility, ease of operation, user-oriented construction and precision engineering. In addition to the well known features of all the former Exakta Models, the new 1970 Exakta VX-1000TL has: Instant Return Mirror, Retro Counter, Short Stroke Rapid Film Advance, Black Non-Glare Dials. It has a Streamlined Body, Self-Aligning Combination Rewind Clutch and Rewind Crank Handle. "No-Hands" Rewind Button. Improved Slow Speed Mechanism. Improved Back Safety Catch. New Hi-Flect Mirror, New Type Safety Light Trap.

These are just some of the ADDITIONAL features. I take it for granted that all you good customers know the BASIC features of the Exakta. It would take too many pages to list them, from the interchangeability of lenses and finders to the 29 shutter speeds (NO other camera has such a range of speeds!). From the optional Behind-the-Lens Exposure Meter Prism to the three separate synchronizers (an Exakta Exclusive!). From the famous Film Cutting Knife (another Exakta Exclusive!) to the Cartridge-to-Cartridge Film System which gives you your choice: rewind or don't rewind. All other 35mm SLR cameras are just Johnny-come-lately copies of the Exakta whose original construction, still basically unchanged, emerged in 1937!

And it, should not be necessary to point out that German Workmanship has never been equalled anywhere in the world.

You may think that I am prejudiced. But I am not. I am as open minded as anybody and have been trying out many makes of cameras. After all, you cannot really know your own line if you don't compare it with others. The answer - just look at my pictures in our showroom. Every last one is an Exakta shot. Try as I may, I have never been able to duplicate my Exakta work, no matter what camera I use. No, I am not prejudiced, but I am SOLD on the Exakta.

**You can buy bodies from us, or just about any component, finder, focusing insert, lens carrying case; or you can buy complete cameras with lens, with and without Behind-the-Lens Metering System.**

**Exakta VX-1000TL, Original Ihagee PentaPrism, Combination Fresnel Viewing Screen and MicroGrid Focusing Aid, fully automatic genuine Jena 50mm F2.8 Tessar Lens, \$87.50 plus \$7.85 for the case and \$1.95 Shipping Charges.**  
**Same, but with F2.8 fully automatic Meyer Optik Domiplan, \$79.50 plus \$7.85 for the case and \$1.95 Shipping Charges.**  
**Same, but with F/2 fully automatic genuine Jena Pancolar \$99.50 plus \$7.85 for the case and \$1.95 Shipping Charges.**  
**Same, but with fully automatic Schneider Xenon F1.9 \$144.50 plus \$7.85 for the Case and 1.95 Shipping Charges.**

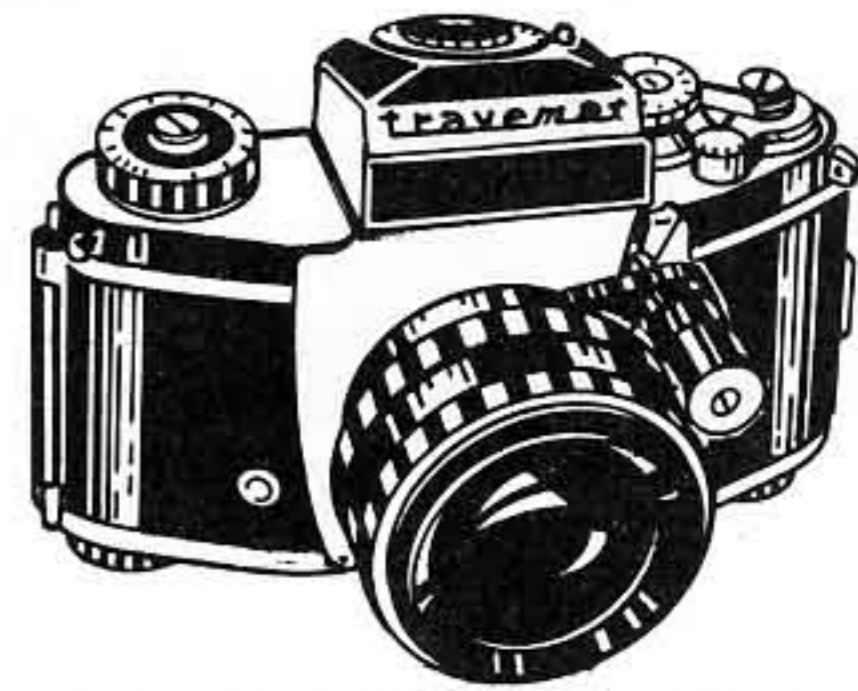

**Exakta VX-1000TL/BTL, with New Model Travelmat Behind-the-Lens Metering Prism with Combination Fresnel Viewing Screen and MicroGrid Focusing Aid with F2.8 fully automatic Meyer Optik Domiplan \$109.50 plus \$17.85 for the special Case with Extra High Top and \$1.95 Shipping Charges.**  
**Same, but with fully automatic F2.8 genuine Jena Tessar \$117.50 plus \$17.85 for the case and \$1.95 Shipping Charges.**  
**Same, but with fully automatic F/2 genuine Jena Pancolar \$129.50 plus \$17.85 for the case and \$1.95 Shipping Charges.**  
 Cases come factory packed with cameras. Purchase of case is mandatory.

**Same, but with fully automatic Schneider Xenon F1.9 \$174.50 + 17.85 for the Case and 1.95 Shipping Charges.**

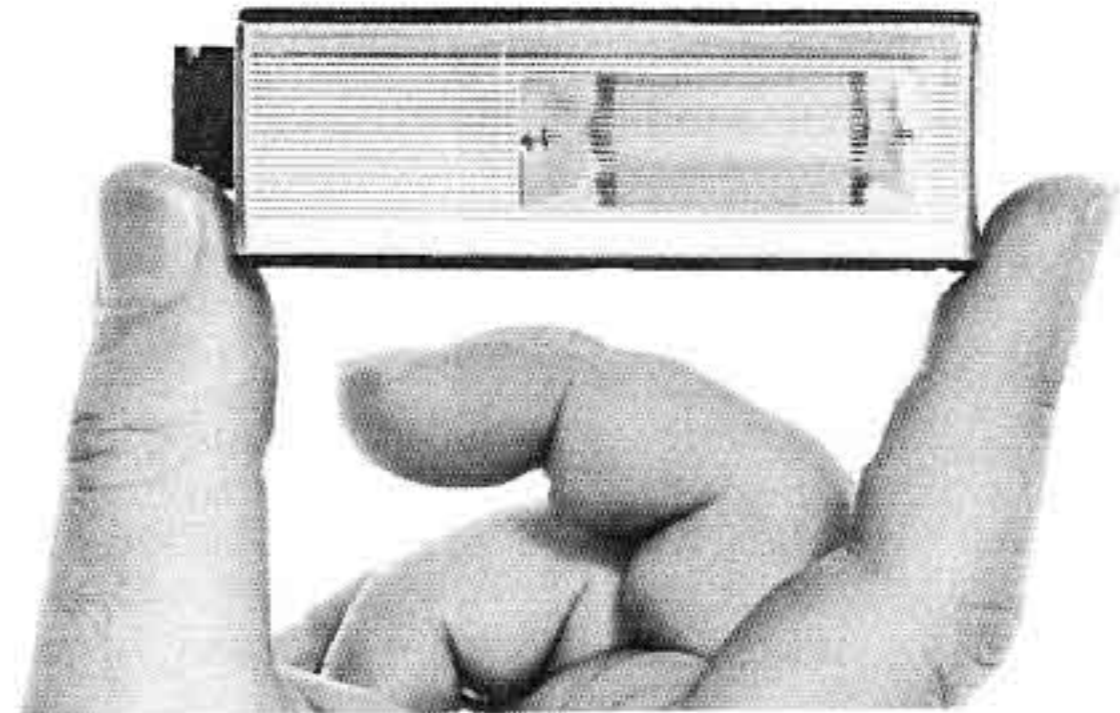

## New Strobe has Perma-Power

Many customers have asked me to find a strobe unit which is powerful, unusually small, equipped with re-chargeable Nickel Cadmium Batteries and built-in charger, and which they can buy without mortgaging their home. It should have all the features of a hundred-dollar unit except one: the hundred-dollar price tag!

All right, I found it: the new German PERMA-POWER HELIOTRON Electronic Flash Unit. Unbelievably compact, a mere 2½ x 3¼ x 1¼". Unbelievably powerful, an honest Guide Number of 40 for Kodachrome II. Unbelievably light in weight, a mere seven ounces. Ruggedly constructed and hand crafted in the true German tradition.

It comes complete with rechargeable power source and with built-in charger. Fast re-cycling (8 seconds) and uniform light output make it the choice of the professional. True palm-size compactness makes it the choice of the amateur. Use it indoors from any AC outlet or use it "cordless" anywhere from its own nickel-cadmium battery-powered energy source. Re-charge the NiCad Batteries as often as you want - they will never "wear out."

The new Heliotron Perma-Power Strobe is equipped with a new Gold Toned Flash Tube. Now, at last, color slides will no longer have the bluish cast that makes skin tones look pale and unnatural. The light from the gold toned flash tube has sunny daylight quality; it produces beautiful, natural skin tones as well as more pleasing overall color quality.

**HELIOTRON PERMA STROBE, specially Seymour-priced at an unbelievably low \$29.95 + 3.95 for the case and \$1.25 Shipping Charges.**



## Reproslide Slide Duplicator

There are two types of camera buffs.

Type A enjoys complicated Rube Goldberg style setups, the more complicated, the better. He proudly tells you how he hooked up tubes, bellows, a discarded piece of stovepipe, the left lens from Uncle Paul's eyeglasses, two hundred and seventy dollars' worth of assorted custom-machined couplers and adapters and . . . oh, he almost forgot to tell you what he was going to do with the rig: he was going to duplicate some slides. Well, he didn't have all the bugs out of the setup, but once it was ready . . .

And there is Type B who enjoys getting results by just pushing a button. If he wants to duplicate slides, he just wants to put a gadget on his camera, drop a slide into the gadget, push the shutter button and come up with a perfect copy.

If you are Type B and have been searching for a self-contained "thing" that makes perfect duplicates of your slides without additional accessories, search no further! You have found it:

The new Reproslide is a self contained slide duplicating "rig." Nothing else is needed, no tubes, no bellows, no auxiliary lenses, no stovepipes, not even a lens! It's all in the Reproslide, including a special flat-field copying lens. You bayonet the Reproslide directly into your Exakta, drop a slide into the Reproslide and shoot. Slides can be unmounted, mounted in cardboard or glass, or they can be in the form of film strips. You can use any light source, even daylight. The result: a perfect exact copy every time. No reduction, no enlargement: Exact same size. Want to make negatives from slides? Want to make black-and-white slides from negatives? No problem!

The Reproslide is Seymour-priced at only \$19.95 + 95¢ Shipping Charges. Remember: it is entirely self-contained. Nothing else is needed. Not even a lens!



## 135mm F2.8 Automatic Steinheil Macro-S Tele-Quinar

## Still Offered at Old (Pre-Increase) Price

We still have a small (but rapidly dwindling) supply of the 135mm F2.8 fully automatic Steinheil Macro-S Tele Quinar Lenses. While this small supply lasts, we can sell them at the old price, and, what is even more important, we can make immediate shipment!

135mm F2.8 fully automatic Steinheil Macro-S Tele Quinar \$159.50 plus \$1.25 Shipping Charges. DeLuxe Leather Case \$4.95 DeLuxe Velvet Lined Pouch \$3.95. Original Steinheil Shade \$3.95



## Exakta VX-500

### Why pay for Shutter Speeds which you never use?

Never in the history of the Exakta has there been a model which caught on as fast as the Exakta VX-500. When Ihagee showed me the first prototype of the VX-500 a short while ago (when the camera was still "under wraps") I predicted that the camera would be a great success. But, enthusiastic as I was, even I could not foresee the phenomenal immediate acceptance of the new Exakta Model.

The Exakta VX-500 is a full fledged Exakta. Don't confuse it with the mis-named "Exakta 500" which was really nothing but an Exa. The new Exakta VX-500 takes all Exakta Lenses and all Exakta Finders, including the BTL Finders. In fact, the Exakta VX-500 is virtually identical to the Exakta VX-1000 except for the shutter speeds which range from 1/30 sec. to 1/500 sec., more than adequate for 99% of all the shots you'll ever take. The Exakta VX-500 has such desirable features as the Instant Return Mirror, The Retro Counter, The Cartridge-to-Cartridge Film System, the Combination Clutch and Rewind Handle, and so on.

The Exakta VX-500 is ideal as a first camera, and just as desirable as a second camera for the "old" Exakta Owner.

Exakta VX-500 with Model C Hooded Reflex Finder with Captive Groundglass with 50mm F2.8 fully automatic Meyer Optik Domiplan \$49.95 + 7.85 for the Case (mandatory) and \$1.95 Shipping Charges.

#### Optional Modifications:

Model N Waistlevel Finder with interchangeable focusing inserts, instead of Model C., complete with Fresnel Viewing Screen and MicroGrid Rangefinder, add \$6.95.

Original Ihagee PentaPrism with Combination Fresnel Viewing Screen with MicroGrid Rangefinder (instead of Model C Finder), add \$9.80.

50mm F/2 fully automatic genuine Jena Pancolar, instead of Domiplan, add \$19.95.

Black deLuxe Camera Case with Detachable Front (instead of Standard Carrying Case) add \$2.00.

You may buy the Exakta VX-500 Body only, as follows:

Exakta VX-500 Body, less lens and finder \$39.95 + 7.85. Case + 1.95 Shipping

Exakta VX-500 Body, less lens, but with Model N Hooded Reflex Finder with Fresnel Lens and MicroGrid \$49.95 + 7.85. Cast + 1.95 Shipping

Exakta VX-500 Body, less lens, but with PentaPrism with Fresnel Lens and MicroGrid \$54.50 + 7.85. Case + 1.95 Shipping.

## Close-Out Rewind Handle



For Models VX and VX11a  
Reduced from \$2.95 to \$1.45. Shipping 15¢



# Trade up!

**The new 50mm F/2 fully automatic genuine Jena Pancolar with automatic Depth-of-Field Indicator**

in exchange for your

Fully automatic Tessar F2.8 . . . . .	\$19.95 + 95¢
Cocking auto Tessar or Biotar . . . . .	\$27.50 + 95¢
Preset Tessar or Biotar . . . . .	\$34.50 + 95¢
Most other 50mm Lenses . . . . .	\$36.50 + 95¢

## Gen. Jena Macro Lens has Self Compensating Diaphragm



The wizards of Jena (which, incidentally, is pronounced "YAY-nah") have come up with an entirely new Wide Angle Lens which doubles as Macro Lens (or, if you prefer, a Macro Lens which doubles as Wide-Angle Lens, because we don't really know what came first) the fabulous 35mm F2.8 fully automatic Jena MACRO-Flektogon.

The correction is superb. The detail and the correction are unbelievable. The Focusing Range reaches from Infinity to four inches. All without tubes, without bellows, without auxiliary lenses!

In Jena, they find YOUR optical problems and SOLVE them! --- One of the most difficult problems of close-up photography is the Compensation of Exposure which becomes necessary when you focus close-in. So, the wizards of Jena built a little computer (or whatever it is called) right into the lens which automatically compensates accurately for the difference in exposure. As you focus, the diaphragm opens automatically in the exact ratio of the loss of illumination. In practical terms this means that you use the settings your meter tells you and leave everything else to the lens. Now, for the FIRST TIME, you get correctly exposed close-ups without even bothering to remember such things as exposure compensation, calculating, measuring distances, or what have you. If your meter says F/8 -- you set the automatic diaphragm on F/8 and let the lens do the worrying, the figuring, the compensating and the allowing for extension and magnification. You just compensate on your composition, and SHOOT!

**35mm F2.8 Fully Automatic genuine Jena Macro Flektogon. Seymour-priced at an unbelievably low \$89.50 + 1.25 Shipping.**

Case \$4.95, Filter Adapter \$4.50

# Famous German Lens Maker Announces the Ultimate Telephoto Lens



Steinheil now offers the 1971 version of their famous 135mm Lens, the new 135mm F2.8 fully automatic Auto-S ("Super") Tele Quinar. If you are unwilling to compromise, this is the lens for you. Optically and mechanically superior, unexcelled in clarity and wire sharp rendition of detail and 100% color corrected, the new Auto-S Tele Quinar brings out all colors in their original glowing beauty. The Resolving Power is close to the theoretically-possible optimum, resulting in razor sharp pictures with clearly defined detail and crisp contrast.

The Auto-S Tele Quinar is beautifully designed. It is just three inches in length! It has a beautiful non-glare ebony finish. You can switch from fully automatic operation to "Manual" by pushing a button. The Auto-S Tele Quinar has an In-Line Shutter Release in a newly perfected all-metal Automatic Activator Housing.

Optically and mechanically true Steinheil Quality!

**135mm F2.8 fully automatic Steinheil Auto-S Tele Quinar Seymour-priced at only \$89.50 + 95¢ Shipping Charges. DeLuxe Hard Case \$4.95. DeLuxe Velvet-Lined Pouch \$3.95. Original Steinheil Shade \$3.95.**



## 25mm Jena Extreme Wide Angle Lens Gives 80 Degree Coverage

The 25mm F/4 fully automatic genuine Jena Flektogon gives you undistorted ultra-wide (80 Degree!) shots. Use it for sweeping panoramas. Use it for architectural shots. Use it to photograph interiors. Use it for pictures of large groups. Use it wherever you must cover a wide, wide, wide angle but where you must have absolutely undistorted vertical lines.

**The 25mm F/4 fully automatic Jena Flektogon is quite a lens. Order it for only \$89.50 + 1.45 Shipping Charges.**

# Slide Punch ("Notcher")

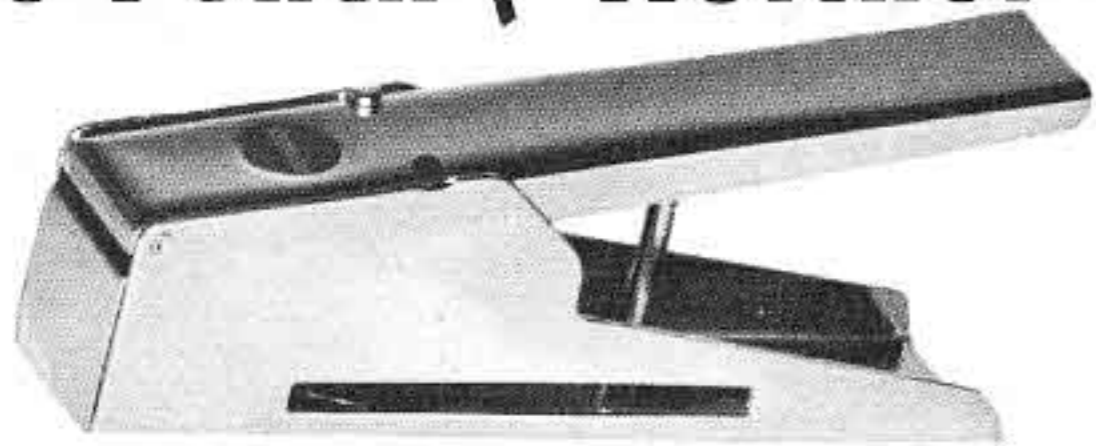

Why do slides have to be "notched?"

When we introduced the new Slide Punch, we thought everybody knew what it was for. Not so. While nobody actually asked for a recipe for the punch, we did get many letters asking how and why.

**WHY:** Cardboard mounted slides have four identical edges and two identical sides. Did you know that there are eight (yes, eight!) ways to put a slide into a projector, a magazine, or a viewer? Obviously, only one of the 8 positions is correct. Slides can be upside down, on their sides, reversed (so that COCA COLA signs read ALOC ACOC in mirror writing) or reversed AND upside down, or reversed AND on their sides, etc.

There is only one way to prevent this embarrassing interruption of slide shows: Punch a notch into the cardboard which tells you visually (when it's light) and by touch (when it's dark) which way the slide "goes." When you place the slides into a magazine, the lined-up notches immediately signal any slide whose notch does not line up with the rest of them. The punch gadget is designed to put all the notches in exactly the same spot on all slides.

**HOW:** You drop the slide into the punch and press. Your slide comes out with a visible and "feelable" notch.

Once your slides are notched, it is impossible to insert them in any of the seven wrong ways. Without guesswork, without time-consuming trial-and-error, all your slides are quickly lined up correctly. No more "Oops! Sorry!" when you project your slides, no more embarrassment, no more mood-killing interruptions.

The Slide Punch is an all-metal Precision Instrument and is priced at only \$2.95 + 35¢ Shipping.

## 35mm F3.5 fully automatic Steinheil Auto Culmigon



35mm F3.5 Steinheil Auto Culmigon  
Fully Automatic Diaphragm (3.5 to 16)  
Focuses to 2½ ft. Non-glare Finish.  
Auto/Manual Switch. In-Line Release.  
Takes 49mm Accessories. Ultra Compact.  
Famous Steinheil Quality  
Seymour-priced at only **44.50**  
Case 3.95 Shipping 95¢  
Orig. Steinheil Shade 3.95



## For the Budget Minded a Seymour-Rebuilt Exakta!

Fine Otto-pampered specimens, all rebuilt to Otto Standards. Every Seymour-Rebuilt Exakta carries an unconditional guarantee. No "fine print": One Year Guarantee on Labor and Parts. Period. Same Guarantee as new cameras. Period.

Seymour-Rebuilt Exakta VXIIa:-

Body, less lens and finder \$39.95 + 1.95 Shipping Charges.

Complete Camera: with Prism, MicroGrid

with fully automatic Meyer Optik F2.8 \$58.50 + 1.95

with fully automatic Jena Tessar F2.8 \$64.50 + 1.95

with fully automatic Jena Pancolar F/2 \$77.50 + 1.95

Slightly used Case \$5.95. Brand new Case \$7.85

## Free Estimates on Exakta Repairs

Occasionally we receive a letter asking us for an estimate of repair charges. Obviously, we must see the camera first, open it up and determine what is needed in terms of parts and labor. There is no charge for this service (other than return shipping charges) and the decision is entirely yours whether you want us to go ahead with the repair or not.

Repair work is mostly labor and you are charged on a time basis. Our technicians don't have to fumble and waste time. They service Exaktas all day long - and nothing but Exaktas. They don't waste their time and your money! They are experts in their field. They do the work fast, they do it right, and they save you money.

We maintain a parts inventory of more than three thousand parts, including scarce parts and factory assembled sub-assemblies. We have special tools (without which you cannot service Exaktas) and we have instruments and test equipment (without which you cannot check shutter speeds, synchronization, alignment of the optical axis, or focus coordination!)

Our Service prices are the lowest at which satisfaction can be guaranteed.

For a free Service Estimate, do this: Pack your camera in a corrugated box, well protected by crumpled newspaper all around the camera. Attach a tag to the camera itself, giving your full name and address and describing briefly but clearly what ails the camera. Mark the tag: "Estimate Only." Mail the package by insured parcel post to: Seymour's-Exakta, Service Department, 350 West 31 Street, New York, N. Y. 10001.

We'll do the rest.



## Famous Macro Kilar Below Dealer Cost

An incredibly lucky purchase enables us to bring you a fabulous Macro Lens at an unbelievably fabulous price. The lens needs no introduction; it is none other than the famous Macro Kilar! Praised for its ultra sharp correction and its unusual focusing range (from Infinity to four inches), the Macro Kilar has been the subject of many articles in professional journals. Among scientists, medical photographers, and close-up fans, the Macro Kilar has an almost fanatical following. And the reputation is well deserved.

The 40mm F2.8 preset Macro-Kilar Model E works equally well as a wide angle lens at normal working distance, as a mid-range lens at moderate close-up distances, and as an extreme close-up lens at a range as close as four inches. Needless to say, the focusing range is unbroken and continuous.

The Dealer Net Cost of this lens is \$100.00. The User Net Price is \$150.00. We made a lucky purchase of a limited quantity of these highly desirable lenses and offer them on a first-come, first-served basis below dealer cost. Please order right away. When we say that we have only a limited quantity, we mean just that. This is a "one-shot deal" and once they are gone, there will be no more.

**40mm F2.8 Macro Kilar Model E \$89.50 + 4.95 for the case and \$1.25 Shipping Charges.**



## 180mm F2.8 fully automatic Jena Sonnar

The 180mm F2.8 fully automatic genuine Jena Sonnar is the latest version of the famous Olympia Sonnar, originally designed as the long-range miracle lens for the Olympic Games, at the request of the famous German photographer Leni Riefenstahl. Re-designed and optically improved several times, it is now available as fully automatic Exakta Lens.

For theater work and available-light sports photography the 180mm F2.8 Jena Auto-Sonnar has no rival. You can probably think of many uses for a fast lens of longer-than-usual focal length with fully automatic diaphragm. Perhaps you are a doctor and want to take photographs in the Operating Room. Perhaps you only want to impress your friends with a big, beautiful, expensive-looking lens. Whatever your excuse for buying it, don't let me stop you from ordering it. Depending on the number of people who break down and order it, this may very well be the last time at which you can buy this magnificent piece of glass at the old price.

**180mm F2.8 fully automatic Jena Sonnar \$159.50 + 2.95.**

## New German Strobe is World's Smallest

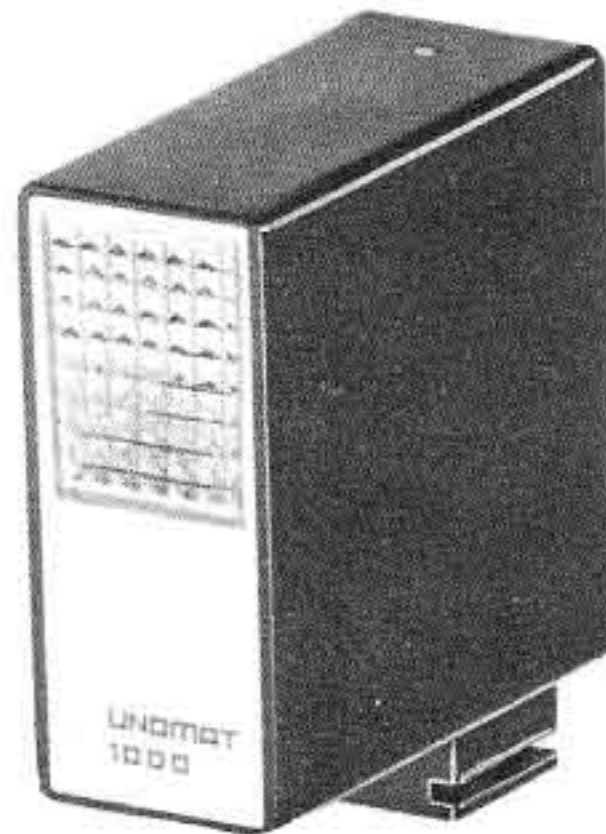

The value of a Swiss watch is inversely proportional to its size. The same seems to be true of a strobe flash. The well-known German Unomat Strobe has just been reduced to an unbelievably small size. The former model, considered irreducible in size, was the size of a pack of cigarettes. The new 1971 Model (already available from Seymour's-Exakta for immediate shipment) is HALF the size of a pack of cigarettes! And the unit now contains rechargeable batteries AND a built-in Charger! Hard to believe? To tell you the truth, I did not believe it either till I saw it! And there is NO reduction of the light output: still an honest 48 for ASA 50. The other specifications are also unchanged:

Angle of Coverage: 65 degrees. Recycling Time: AC 6 seconds, NiCads 10 Seconds. 60 Flashes per Charge. Flash Tube Guaranteed for 10,000 flashes.

Considering that you had to shell out \$7.50 for the NiCad Batteries for the old model Unomat Strobe, and \$12.50 for the Charger, the new model is actually priced LOWER than the old one because the NiCad Batteries and the AC Charger are built in and INCLUDED in the low price of only \$39.95 plus 1.25 Shipping Charges.

**Unomat Model 1000, the World's Smallest Strobe Unit, complete with built-in NiCad Batteries and AC Charger, \$39.95 + 1.25 Shipping Charges. Accessory Shoe \$1.95.**

## Powerful German Strobe Flash has Built-in Slave.

### Fires Without Hookup.

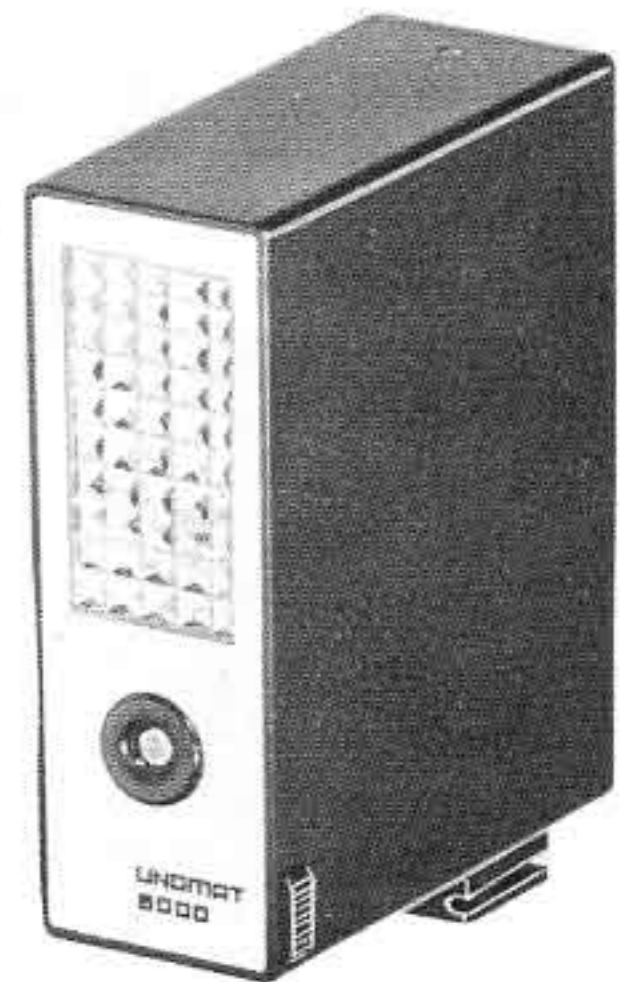

Unomat (who gave you the World's Smallest Strobe Unit) now brings you its new powerful Model 6000. Its high light output will allow you to shoot at lower F stops or greater distances, even with slow film. Used by itself, it hooks up just like any other strobe, and synchronizes with your shutter, but used in conjunction with any other strobe (Heliotron Perma Strobe, Unomat Model 1000, or what have you) it will fire totally independently, in perfect synchronization, without any physical hook-up. The built-in "Slave" sensor automatically triggers the Unomat 6000 with zero time delay.

Specifications: Angle of Coverage: 65 degrees. Recycling Time: AC 6 seconds. Batteries: 10 seconds. Guide Number: 80 with ASA 50 film. Operation: from any AC outlet or from its own built-in NiCad Batteries. Charger: Built in. Better than 40 flashes per charge.

**Unomat Model 6000 Powerful Strobe with Slave Triggering Mechanism, complete with NiCad Batteries and built-in Charger \$59.50 + 1.45 Shipping Charges. Accessory Shoe \$1.95.**



# Mirror Lens

Don't ask me how, but I finally got hold of the real McCoy! This 500mm F/8 Mirror Lens is not one of the cheap imitations which have been floating around those last few years. It's the genuine article all right!

You have never seen such wire sharp resolution in a super telephoto lens. At least I haven't! It costs more than the cheap copies (naturally) but since it comes to you from Seymour's-Exakta, it doesn't cost \$1150.00 either.

It comes in a hand made fitted wooden carrying case and with four mounted Screw-in Filters of unbelievable plano-parallel properties, all in keeping with the quality of the lens itself.

Genuine "M.T.O." 500mm F/8 Mirror Lens, complete with Fitted Carrying Case and 4 Mounted Filters, Seymour-priced at only \$269.50 + 2.95 Shipping Charges.

## Our Telephone 212-CH 4-1150 Company Policy: No Collect Calls



### Top Grain Cowhide Bag

Bag measures a generous  
12 by 10 by 6 inches.

These trim Luxury Gadget Bags feature the finest Top Grain Cowhides available. Highest Quality U. S. Workmanship throughout - the Best!

Heavily padded top. Finest Hardware. Heavy-Duty Zipper (and we mean HEAVY Duty!) Lined with soft felt for added protection of delicate equipment.

Adjustable inside Belting separates accessories and holds them securely.

Double Size Outside Pocket. Zippered Inside Pocket. Adjustable Extension Carrying Strap.

Top Grain  
Cowhide Gadget Bag Special Seymour Price

**29.50** + 1.65 Shipping

## Uncertain What to Give? Give a Seymour Gift Certificate

Let the recipient choose his own gift from the inexhaustible treasure chest of Exaktas, Lenses and Accessories from Seymour's Exakta. A Seymour Gift Certificate is always right.

Available Denominations:

\$5.00 \$10.00 \$15.00 \$25.00 \$50.00 \$100.00 and Multiples.

Easy to order: Give us name and address of Recipient and your own name and address and send remittance. Be sure to tell us whether to send the Certificate to Donor or Recipient.

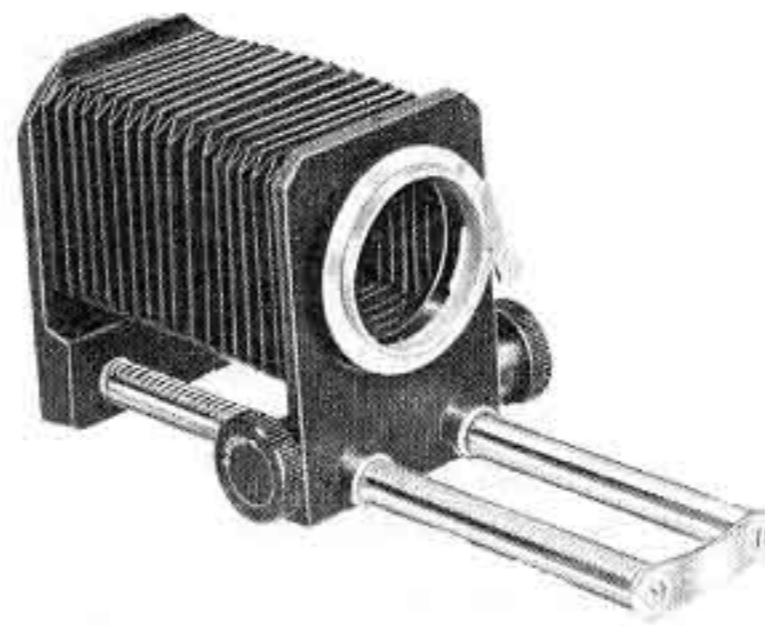

Models  
TW-5 and TW-7

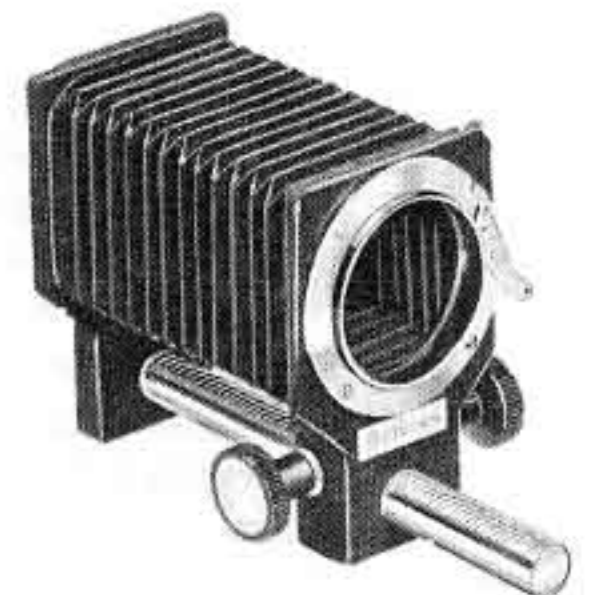

Model  
MR-05

## Exakta Bellows

### NEW TWIN-ROD MODELS:

With geared Rack-and-Pinion Precision Focus  
Model TW-5, Full 5-inch Extension...\$17.95 + 95¢ Shipping  
Model TW-7, Extra Long 7" (180mm) Extension....\$19.95 + 95¢ Shipping

### NEW MONORAIL MODEL:

With geared Rack-and-Pinion Precision Focus  
Model MR-05 Full 5-inch Extension..\$13.95 + 95¢ Shipping

## Short Barrel Lens

### for Use in Bellows

These lenses are especially corrected for use in bellows for a wide range of close-up ratios. They render sharp, crisp, well color-balanced pictures. Their longer focal length provides a convenient working distance with plenty of room to light your subject adequately.

135mm F4.5 preset Travenon  
\$19.95 + 95¢



Our Top-of-the-Line Twin Rod Bellows Unit with extra long Seven-Inch Extension (Model TW-7)

plus the 135mm F4.5 4.5 preset Short Barrel Lens

Save

an additional \$5.15

**\$34.75** + 95¢ Shipping





## Fully Automatic 135mm F3.5 Schneider Isco Westanar

Seymour-priced  
at an  
unbelievably low

# 49.50

Case \$4.95. Filter Adapter \$4.50. Shipping 1.25

*Best value*



### Original Ihagee PentaPrism

without Insert . . . . . \$14.95 + 65¢  
with Fresnel Screen and MicroGrid . . . . . \$18.50 + 65¢

#### Focusing Screen Inserts:

Finegrain Groundglass . . . . . 3.95 + 35¢  
Fresnel Screen and MicroGrid . . . . . 7.50 + 35¢  
Groundglass and MicroGrid . . . . . 4.95 + 35¢  
Split Image Rangefinder Insert . . . . . 6.95 + 36¢

#### Scientific Screen Inserts:

Groundglass, Clear Spot . . . . . 14.95 + 35¢  
Groundglass, Crosshairs . . . . . 14.95 + 35¢  
Groundglass, Overall Squares . . . . . 19.50 + 35¢  
Clear Glass, Crosshairs . . . . . 19.95 + 35¢  
Groundglass, Clear Spot, Crosshairs . . . . . 19.95 + 35¢

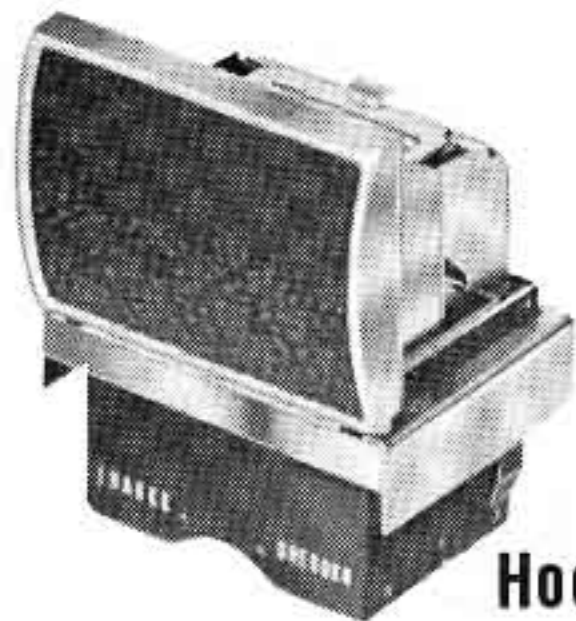

**Original  
Ihagee**

**Hooded Finders**



If you are not using the Hooded Finder, you are wasting half the possibilities of your Exakta. Indispensable for low-angle shots, copying, close-up work, right angle (secret) photography, etc. The Hooded Finders have Fold-Away Magnifiers for critical focusing.

Hooded Finder, Model C, with Captive Groundglass . . \$8.95 + 65¢  
Hooded Finder, Model N, (Takes Interchangeable  
Glasses) supplied without insert . . . . . \$11.95 + 35¢

(Model N takes the same Inserts as the PentaPrism)

#### Special Combination:

Model N Hooded Finder with Fresnel and MicroGrid . \$15.95 + 35¢

Case, takes Hooded Finder or Prism \$2.95 + 35¢



## Automatic Tele Converters

Our new Automatic Tele-Converters inexpensively increase the focal lengths of all your lenses. Your automatic lenses remain automatic but you can use the Tele-Converters with non-automatic lenses as well.

The Automatic Tele-Converter (ATC) fits between the Bayonet Mount of your Exakta Camera and any (any!) Exakta Lens. A 50mm Lens becomes a 100mm Portrait Lens with a 2x Converter (ATC/2). A 135mm lens "grows" to 270mm with an ATC/2, to 400mm with a 3x Converter (ATC/3), to 800mm with one ATC/2 plus one ATC/3 or to an incredible 1200mm with two ATC/3 Converters. You can determine the increase as follows:

One ATC/2 . . . . . double  
One ATC/3 . . . . . triple  
Two ATC/2 . . . . . four times  
One ATC/2 plus one ATC/3 . . . . . six times  
Two ATC/3 . . . . . nine times

Once more we offer these fine instruments at Special Prices:

ATC/2 . . . . . \$19.95. Case 1.95. Shipping 95¢  
ATC/3 . . . . . \$24.95. Case 1.95. Shipping 95¢  
Two ATC/2 with Cases . . . . . \$36.00. Shipping 1.25  
Two ATC/3 with Cases . . . . . \$45.00. Shipping 1.25  
ATC/2 plus ATC/3 with Cases . . . . . \$39.00. Shipping 1.25



## Ultra-Ultra Wide Angle from Jena (whom else?)

Perhaps you don't need an Ultra Wide Angle Lens with a coverage of One Hundred Degrees (!) but if you do want such extreme angular coverage, we have the lens for you: the new, fully automatic, genuine Jena 20mm F/4 Flektogon. Superbly corrected in the true Jena tradition.

If we discount gimmicks like fish-eye-view lenses (which are not really wide angle lenses since they give you only a circular image), the 20mm Flektogon is the absolute maximum in wide angle coverage. For interiors, large groups, architecture, there just isn't anything like this unusual Ultra Wide Angle Lens. And if you have ever tried to photograph the Fontana di Trevi in Rome, you know what I am talking about when I mention coverage of a scene where you just can't step back far enough to get it all into the picture.

In the face of rising prices we bring you the 20mm F/4 Fully Automatic genuine Jena Flektogon at a price nearly 25% lower than the one shown in our former catalog No. CH-65. Once in a while we make a lucky purchase and when we do, we pass the savings on to you. Just to re-assure you: the lenses are brand new and the very latest model.

20mm F/4 Fully Automatic genuine  
Jena Flektogon, Special Price . . . . . \$135.00  
plus 1.25 Shipping Charges. DeLuxe Velvet Lined Pouch . . . \$3.95

## 28mm F3.5 Caspeco preset Wide Angle Lens

A new optical Retrofocus formula in conjunction with newly-developed Rare-Earth optical glass types makes this ultra-wide Wide Angle possible. Unsurpassed in sharpness and color correction. Never before could you hope to get a 28mm Extreme Wide Angle Lens at such a price. Excellent for Interiors, Panoramic Scenic Shots, groups, etc. Fast-acting, positive preset diaphragm. A truly unusual lens; a truly unusual buy!



**\$29<sup>95</sup>**

Case 2.95

+ 95¢  
Shipping

## GIANT Release Button

Convenient, Fumble-Free, Soft Release. Eliminates Camera Shake. Trip the shutter even with mittens! Precisely machined. All Metal.

GIANT RELEASE BUTTON . . . . . \$1.25



**50mm F1.9**

automatic  
Schneider

**Xenon  
89.50**

Shipping Charges . . . . . \$1.25

Yes, it says XENON, the real McCoy!



## 22mm F2.8 Macro Doryt Ultra Close-Up Lens

This is a special adaptation of a genuine Microfilm Lens. You know the task a microfilm lens has to perform: its Resolving Power must be the theoretically obtainable maximum. There can be no curvature of field, no edge fall-off, no internal flare.

We have adapted this ultra-ultra sharp lens for use in 35mm cameras. It covers a field of 3/4" by 1", thereby giving a magnification of 50 per cent over life size. Roosevelt's face on a dime will fill the frame. Wait till you project THAT!

Fix-Focus Mount. No diaphragm needed, because wide open the Macro Doryt resolves 160 lines! Microfilm lenses have never before been available for use in conventional 35mm cameras. You are in for quite a surprise!

22mm F2.8 Macro Doryt  
complete with Exakta Bayonet **\$9<sup>45</sup>**  
+95¢ 10

## Lucite Cube

## Displays

## Your Pictures

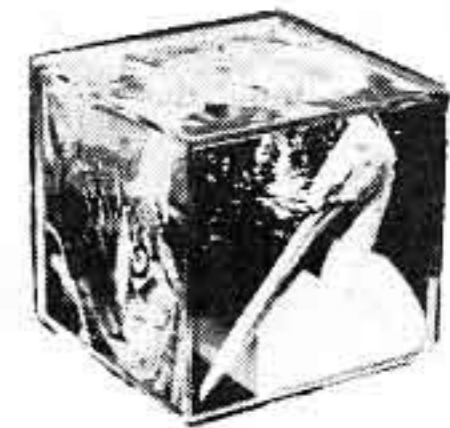

This new Lucite Cube is a beautiful ornament for any desk, table, or shelf. Slip five of your favorite shots (or 5 shots of your favorite people) under the gleaming Lucite Windows where they are being shown to best advantage.

Buy several for yourself and many as presents. Because of our special more-than-one "deals," the more you buy, the more you save on each Lucite Cube.

Please do not confuse these 3-1/2-Inch Lucite Cubes with the puny Two-inch cubes you may have seen in camera store windows. Our Lucite Cube is a large, beautiful 3-1/2 x 3-1/2 x 3-1/2 Inches, a joy to behold.

Lucite Picture Display Cube . . . . . \$2.95 and 25¢ Shipping

Buy two, get an additional one free. Buy five, get three additional cubes free.

## Micro Grid

A new ultra precise  
Focusing Screen for  
the Exakta. The Micro  
Grid is surrounded by  
a light-gathering Fresnel Screen.

**7<sup>50</sup>**  
+ 35¢

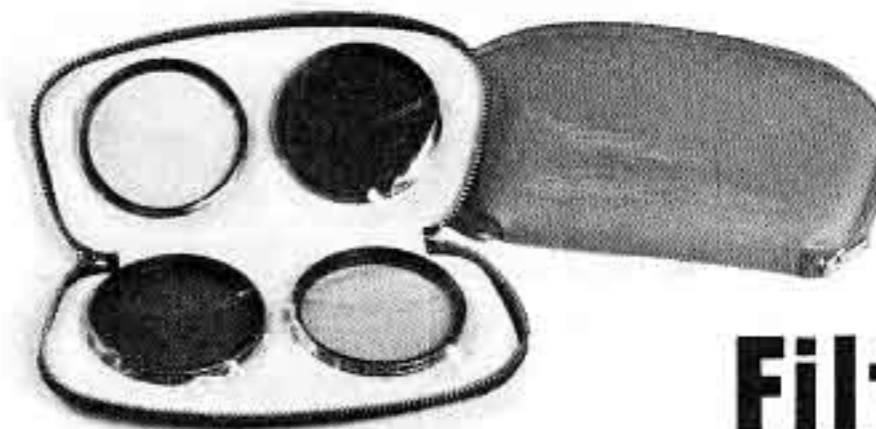

## Filter Pouch

This beautifully designed Filter Pouch protects your delicate Filters from dust and scratches. Four filters are in full view. Filters are held in four clear, transparent "windows." A smooth zipper seals out dust. Makes a nice inexpensive gift, too.

Zippered Filter Pouch \$1.95 + 25¢ Shipping  
3 for \$4.95 + 35¢. 6 for \$8.95 + 45¢.

## Screw-in Rotating **POLARIZER**

Did you know that there are very few exceptions to the rule that EVERY picture should be shot through a Polarizer? Without a Polarizer, glare obscures color. Roofs, roads, cars, leaves look whitish grey in direct sunlight because they reflect the bright sunlight as glare. A Polarizer cuts through the glare and brings out the true colors which are normally hidden under the glare. Flowers look more natural. Leaves look green. A Polarizer also kills the glare that makes it difficult to photograph through glass (car or train windows, showcases, museum display cases, framed-under-glass pictures). The Polarizer will make the glass "disappear". And, most important, a Polarizer makes the sky take on a deeper blue and clouds show up fleecy white.

Screw-in Rotating Polarizer Ser. VII \$9.85 49mm \$10.85 Postage 25¢

# Color Enlargements Make Wonderful Gifts

For really personal gifts nothing can match Full Color Enlargements of your own slides or negatives.

May we suggest:

**16x20 Giant Enlargements. Special Christmas Finish includes:**

Mounting on Heavy Board, Color Matched Hand Dust Spotting and Matte Finish.

First Print \$37.50 + 2.50 Shipping.

Additional Prints, same subject, \$24.50 each + 1.50 Shipping.

On 16x20 Color Orders over \$100.00 we pay shipping.

**11x14 Special Christmas Gift Quantity "Deal"**

Twenty 11x14 Color Enlargements, same original, glossy finish, unmounted, Total Cost \$98.50 + 2.65 Shipping Charges.

Optional Services:

All prints hand mounted in frame type (cut out) Exhibition Mounts, add \$18.50

All prints Matte Finished, add \$12.50

Please send Color Orders as early as possible to assure Delivery in Time for Christmas.

## Change of Name Offers Opportunity to Buy Lenses at Reduced Prices

For reasons best known to themselves, manufacturers occasionally change the names of their lenses. Perhaps the old name was too similar to a competitor's name; perhaps it did not catch the public's eye. Whatever the reason for the change, the manufacturer usually accepts a lower price for his remaining stock of lenses with the discontinued name.

We have bought such a "remainder" deal and offer them as "XXX" Lenses at great savings. Let me assure you that these lenses are of first quality, both optically and mechanically. Don't let the low price influence your judgment! Every lens is one hundred per cent perfect and I would want you to fire it right back to me if it did not give you razor sharp results.

135mm F2.8 fully automatic "XXX" Telephoto Lens \$49.50, Case \$4.95

28mm F2.8 fully automatic "XXX" Wide Angle Lens \$49.50, Case \$4.95

Shipping Charges 95¢ per lens.

Combination Deal (Save an additional \$10.00):

Both above "XXX" Lenses, with Cases, \$98.90 + 1.25 Shipping

# Famous German Camera has Genuine Jena Tessar F2.8



## Buy it for Less than Value of Lens Alone

*I believe that, over the years, Seymour's has sold more Werra cameras than any other store. Nearly ninety per cent of all Werra cameras were sold by us just before Christmas, year after year. This means that our customers have always considered the Werra the ideal Christmas Gift. So, once more I offer you a Werra for Christmas Giving:*

The Werra is a full-frame 35mm camera. The shutter has a full range from 1 full second to 1/500 sec. The film advance is coupled with the shutter cocking device (single action). Double Exposure Prevention. Blank Exposure Insurance. Full Synchronization for Flash and Strobe. Automatic Exposure Counter. Delayed Action Self Timer. The Screw-in Lens Shade reverses to form a dustproof cover over lens and shutter. The Werra is beautifully designed. It is finished in Satin Chrome and Black leather grained Vinyl.

A camera is as good as its lens. The Werra has a lens whose credentials are world famous: the genuine Jena Tessar F2.8! Brilliant, 100% color corrected, coated and, needless to add, wire sharp.

You would call a 50mm F2.8 Jena Tessar a bargain at \$24.50, wouldn't you? But what would you call an entire camera WITH an F2.8 Jena Tessar at \$24.50? And what would you call an entire camera WITH an F2.8 Jena Tessar and WITH the Reversible Shade and Screw-in Cover and WITH the Metal Trimmed Ever-Ready Carrying Case at \$24.50?

Looks like a misprint, doesn't it? But it's true. The complete Outfit is \$24.50. Shipping Charges are \$1.95. We bought the entire inventory. But when they are gone, there won't be any more. Please don't wait. Order as many as you need for gifts - now! How can you go wrong?

## Close-Out Copy Stand



Consists of Chrome Plated Column, Adjustable Camera Support Arm, "Foot" for attaching column to work bench (or obtain a flat piece of board; baseboard not supplied). Close-Out Price \$12.50 + 95¢ Shipping.

# They're All My Babies...



## Otto's Column

Otto symbolizes the personal interest, the professional pride, the high skill and knowledge of Seymour's Exakta Service. Here's what he has to say:

### Repairs and Service.

Your Exakta is a very special camera. Unlike any other SLR. Designed by engineers, built by experts, assembled by German craftsmen — the Exakta is among cameras what Mercedes is among automobiles.

Of course, everybody knows that a Mercedes will take care of you as long as you take care of it, as long as you have it lubricated, tuned, checked. Believe me, the same is true of your Exakta! Give it good care and it will last almost forever. Listen to the advice of a man who has serviced more Exaktas than he can count:

First, a few "Don'ts":

Don't let your local develop-and-print jockey touch your Exakta. Ever! Even if he is an old hand at repairing cameras, he does not have the factory parts or the sub-assemblies without which even the best repairman cannot service your Exakta. At Seymour's Exakta Lab we have thousands of original Ihagee parts and sub-assemblies. No "universal" parts. Only original replacement parts. And we receive the se parts directly from the factory: the factory knows full well that Seymour's Exakta Service is largely responsible for the ever increasing popularity of the Exakta in the United States.

Don't neglect your Exakta! Extremely fine dust seeps into the intricate shutter movement and lodges between the gears. It combines with the lubricants and becomes a hard (and harsh) abrasive. Don't let this happen! The abrasive will wear out the gears and you will have an expensive repair job on your hands.

Do have your camera cleaned and lubricated once every two years, more frequently if you take it to the beach or to a dusty environment. While we have the camera we clean the gear train, lubricate it to Exakta specifications, check the shutter speeds, check the focus, check the alignment of the mirror and check the synchronization. We make adjustments within the limits of the basic service but our special "Service Package" does not include replacement of parts or major repairs.

For the past five years we have held our price for the "Service Package" to \$24.50 + 1.95 Return Shipping Charges. Because of rising costs, we have to increase it to \$29.50 plus shipping. Christmas Time is a particularly bad time to spring a price increase on our customers. After discussing it with "The Boss," I am authorized to announce a sort of delayed-action: All Exaktas sent in for the "Service Package" between now and January 15, 1971 will be serviced at the old price of \$24.50 + 1.95 Return Shipping Charges.

I know that this will result in a rush of work. You will greatly help me and my crew by following these steps:

**Send your camera by insured parcel post. Attach a tag to the camera itself, giving your full name and address (with ZIP!) and marking the tag "Service Package." Clip your check for \$26.45 to the tag. We'll do the rest!**

Now, remember that this Service Package does not include replacement of parts or major repairs, nor does it cover any work on lenses. If there is something really wrong with the camera or the lens, follow these steps instead:

Send camera by insured parcel post. Attach a tag to the camera, giving your full name and address. Write on the tag **AS BRIEFLY AS POSSIBLE** what is wrong and what you want repaired. Mark the tag "ESTIMATE ONLY" and do not send any money. You will receive an estimate without any obligation on your part.

Best Wishes, and, as we used to say in the Old Country, "Frohe Weihnachten."

Your Exakta Pamperer,  
Otto.

# SAFARI Foam Fitted Attache Case



If you are a Seymour Customer of long standing, you know that it isn't idle talk when we say that we will drop an item from our list, if something better becomes available. Best Sellers on our list are no exception.

For many, many years our Foam Fitted Attache Case has been one of our most successful items. Now, thousands of cases later, the original case must succumb to progress! A new type of injection moulding produces a moulded luggage shell which is virtually impervious to impact damage. To distinguish the new from the old, the new Foam Fitted Attache Case carries the name SAFARI.

Imagine the hazards a case of this sort will have to stand up to on a safari. This new Attache Case overcomes them all. Heat cannot damage the material. While we have never tested the case with a herd of trumpeting elephants stampeding over it, we have a hunch that it would even withstand this kind of impact. Normal hard use (including the tender loving care the airlines give your luggage when it's out of your sight) will neither dent nor break it. Humidity, even rain, cannot damage the contents: the top fits into the bottom by a male profiled rim that engages a female profiled rim to protect the contents from any kind of moisture.

Just like the old model, the new SAFARI Foam Fitted Case cushions your equipment and protects it from jolts. The foam cushions come uncut and you custom fit the case for your equipment: you trace your equipment on paper, cut the foam cushions right through the paper. The whole thing takes only a few minutes.

Now for the best news: you buy the new SAFARI Case at exactly the same price as the old model. And if you consider that it's still the same price as in 1964, you see what a great buy this is:

**SAFARI Foam Fitted Attache Case, Seymour-priced at only \$19.65 + 1.65 Shipping Charges.**

## Aluminum Foam Fitted Case

Same idea as above but all aluminum construction, deeper by 2 inches, and virtually indestructible. \$47.50 + 1.95 Shipping Charges.

**Otto Offers  
a New Crop  
of recently-traded  
completely rebuilt Exaktas,  
many of them less than a year old.  
Every one Otto-pampered  
and fully guaranteed for one year**



**VX-1000 with PentaPrism with MicroGrid,  
fully automatic gen. Jena Pancolar F/2,  
hard to tell from new, \$79.50  
+ 1.95 Shipping.  
Slightly used Case \$5.95.  
New Standard Case \$7.85.  
New deLuxe Case \$9.85**



**135mm F2.8  
preset German  
Telephoto Lens  
A "Best Buy"**

I was lucky enough to get my hands on a "close-out" of one of the sharpest 135mm lenses ever made for the Exakta. I might as well tell you that nobody wanted the lenses because "preset lenses do not sell." The minute I heard of this offer, I put in my bid. It was accepted. Possibly, because there were no other bidders. But nobody knows lenses better than I, and I knew I had a tiger of a performer.

Schneider-Isco 135mm F2.8 preset Tele-Isco, a steal if there ever was one, \$39.50 + 1.25 Shipping Charges.

We also bought a quantity of the original plush-lined hard DeLuxe Cases (fawn-colored glove leather). The case is optional. In fact, we don't have enough of these cases for all the lenses. While they last, you may order one with each lens for \$3.95 if you want to be a big spender.

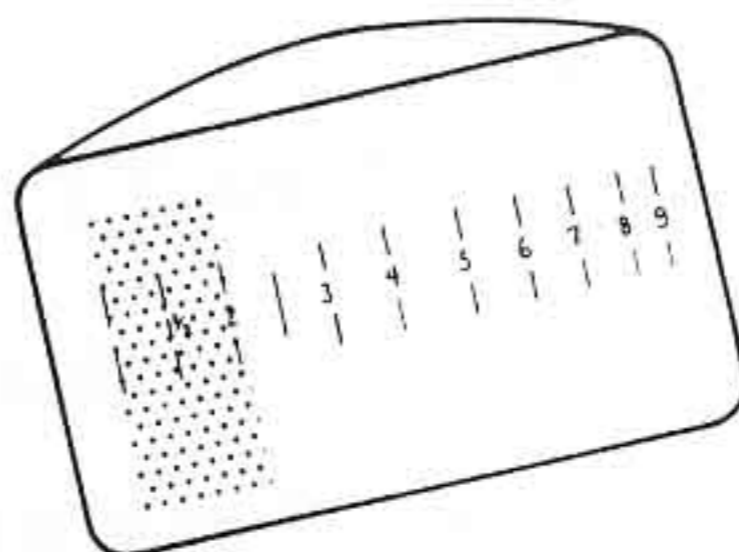

**What's a  
Macrolite?**

A Macrolite is a Direct-Reading Exposure Screen. And what's that? Well, to begin with, it's an insert for the PentaPrism (or for the Model N Reflex Finder) which replaces the conventional focusing insert for close-up work to determine the exposure increase.

You know that close-up work requires an exposure increase. The closer you focus with any given lens, the greater the increase. For a 1:1 ratio (image on film same size as item photographed) you must increase your exposure four times, or, in technical terms, the Exposure Factor is 4. So far, so good. But what will your exposure factor be at a slight reduction in size or at a larger-than-actual-size? While it is possible to calculate the exposure increase, it involves measuring distances, add a few rather involved mathematical manipulations and calculations.

Since a definite relationship exists between Exposure Factor and Relative Image Size, a professor of Mathematics and Physics (an ardent Exakta Fan and inveterate Macro Photographer) developed a scale, based on the linear projection of the above mentioned complicated formula. He engraved it on the focusing screen and could now, without measuring or figuring, read the Exposure Factor directly in his viewfinder. Absolutely ingenious.

The next step was simple: he produced the engraved inserts for other Exakta Close-Up Enthusiasts and appointed Seymour's-Exakta (whom else?) as the sole sales agents. (Incidentally, no other camera has this feature).

If you do close-up work and want to be sure of your exposure, the Macrolite is for you. It is unbelievably easy to use. Replace your regular focusing screen insert with the Macrolite Screen, focus on your coin, stamp, document, etc., and line up the left side of the template with the number 1 on the Macrolite Screen. The right side of the template points to the exact exposure factor as indicated in the above illustration. (It points to 2 which means you have to double your exposure. If it points to 8, you will have to increase your exposure eight times, etc. Complete Instructions come with Macrolite. It's easier to use than to describe).

No more Charts, no more Exposure Tables, no more Measuring, no more Calculations, and, what's most important, no more Exposure Errors! You will get correctly exposed close-ups every time. You read your Exposure Factor directly, at a glance. Right in the viewfinder! The Macrolite is a Seymour Exclusive, available ONLY from Seymour's-Exakta. We offer it for only \$17.50 + 25¢ Shipping Charges, on our regular 15-Day Money-Back Trial Basis.

**Macrolite Direct-Reading Exposure Factor Screen \$17.50 and 25¢ Shipping Charges.**

For the Budget Minded:

A few slightly used Macrolites, a few Demonstrators, guaranteed accurate, \$8.50 and 25¢ Shipping Charges. Same trial privilege, of course.

### **How does the Micro-Grid Work?**

The "Micro-Grid" is a new optical development. Its main advantage: sharp focus is achieved regardless of the user's eyesight. The Micro-Grid superimposes a grid pattern over the image when the lens is out of focus. Once in focus, the grid disappears and the image appears crystal clear. Unlike the split-image, the Micro-Grid does not black out. With the Micro-Grid there is no guesswork: you are either in focus, or out. The Micro-Grid is now available in a combination screen: A light-gathering Fresnel Screen produces a brightly illuminated viewing image (bright from corner to corner). The Micro-Grid is in the very center and around it is a ring of ultra-fine groundglass for a quick visual check of the focus (for the doubting Thomases who don't trust any rangefinder and must be re-assured by a back-up device).

**Combination Fresnel Viewing Screen with Micro-Grid and Finegrain Matte-Glass Ring**

**Original Ihagee Exakta Produce . . . . \$7.50 + 35¢  
Independent Make (also very good) . \$5.95 + 35¢**

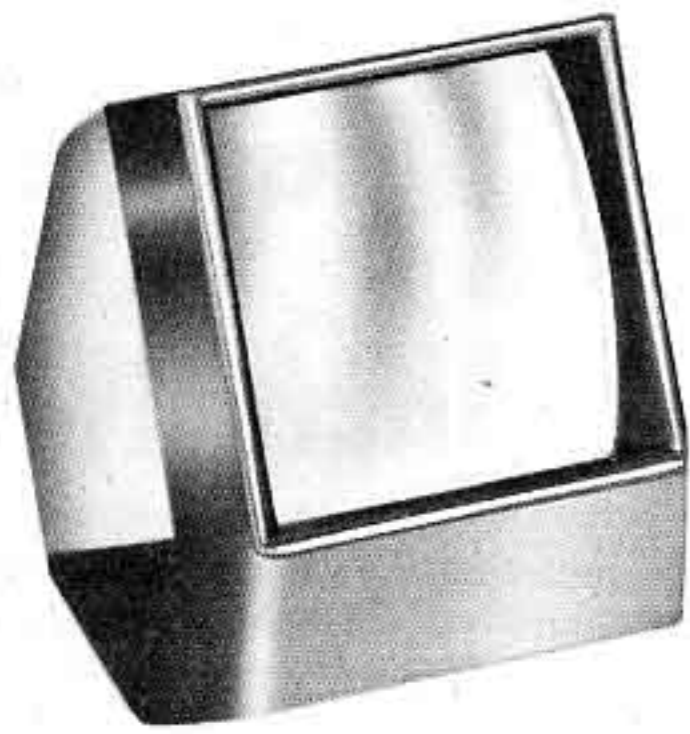

## Betta-Vue Illuminated Hand Viewer

Takes all 35mm Slides, also half-frame slides and Super Slides. Shaped like a miniature TV Set. Comfortable Magnifying Viewing Screen. Light goes on automatically when you insert the slide and goes out when the slide is removed. It is battery operated and you can carry it with you wherever you want to show off your slides.

**Price reduced for Gift Giving!**  
**Betta Vue Slide Viewer reduced to \$1.95 + 35¢ Shipping.**  
 Buy several for small gifts:  
**Two for \$2.95 + 35¢ Shipping**  
**Six for \$7.45 + 45¢ Shipping**  
**Batteries (2 required per Viewer) 10¢ each (not included).**



## Our Best "Pro Bag"

What's a Pro Bag? A Pro Bag is a gadget bag, made of solid thick leather with two straps which come together at the top to form a carrying handle. In addition, it has a heavy duty shoulder strap. You sling it over your shoulder or you carry it like a suitcase. That's a Pro Bag.

But this description goes for any pro bag. What makes our "Status" Pro Bag so much better? Well, for one thing, it is entirely handcrafted by American Craftsmen whose saddlemaking skill was handed down from father to son. The top grain leather is hand waxed to a beautiful, easy-to-care-for finish. The interior is lined with rich golden plushy lint-free velvet. The extra-wide-flare shoulder strap has a built-on non-slip shoulder pad. The brass hardware is lacquer coated to resist wear and maintain its beauty. Two buckled tripod loops securely hold your tripod. The key-lock keeps out inquisitive eyes (and hands!). Our "Status" Pro Bag has a unique snap-open top compartment. You can conveniently open this outside-access compartment without removing the bag from your shoulder.

The size of our "Status" Pro Bag is more than adequate for the Exakta Owner who has quite a bit of gear. Yet it is not unreasonably bulky. The Dimensions are 11" x 6-3/4" x 9-1/2".

The Manufacturer's Retail Price is \$53.00. Compared with what we've seen on the market, this is a very low price for this type of saddlemaker's craftsmanship. Seymour's wouldn't be Seymour's if we would ask you to pay the retail price. You may order the finest Equipment Case you've ever seen, the "Status" Pro Bag, from us for an unbelievably low \$39.95 + 2.35 Shipping Charges. Status, Quality, Beauty, AND Usefulness. At that price you might as well treat yourself to the very best. Live a little!

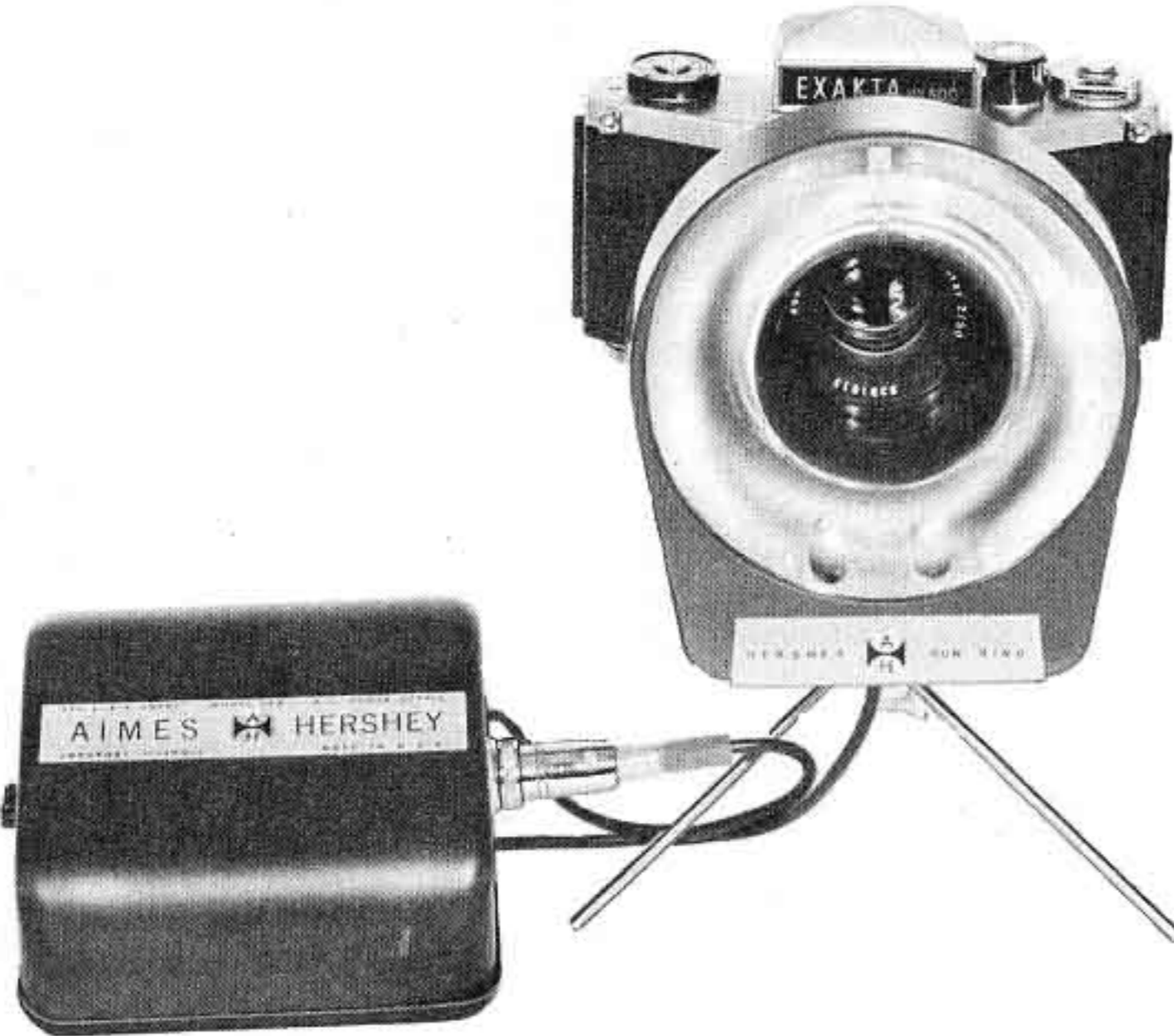

## For Shadowless Lighting Electronic Ring Strobe

Hershey-Introl, the leading U.S. manufacturer of professional strobe units, now supplies a new professional Strobe "Ring" for shadowless "wrap-around" lighting. This type of light is indispensable for even (shadowless) lighting for a great number of close-up and semi-close-up shots.

The new "Sun Ring" attaches directly to the lens by means of a Series VII Filter Adapter. We supply it complete with the ultra powerful (50 Watt Second!) AC Power Supply. It recycles as fast as you can cock the shutter.

Order the Ring Strobe and you will receive everything needed. The Outfit consists of the Ring Light, the Series VII Adapter (state front diameter of lens, in mm), the AC Power Source, and the Camera Connecting Cord.

**14** Hershey-Introl Ring Strobe Outfit \$98.50 + 1.35 Shipping Charges.

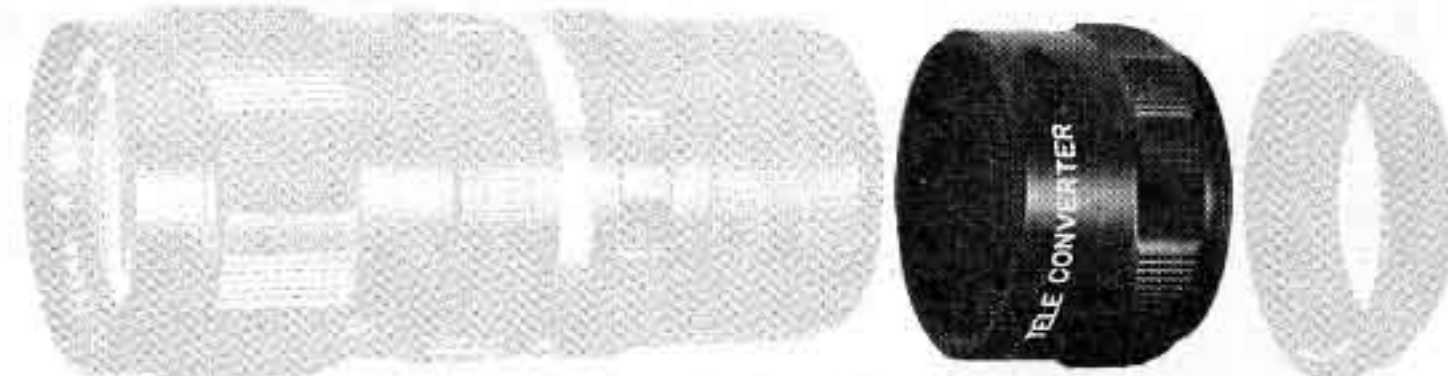

## "Tee" Focal Expander for T-Mount Lenses

An inexpensive way to increase the power of your T-Mount Lenses. The TEE Doubler doubles the Focal Length; the TEE Tripler triples the Focal Length. Both can be used together, giving you six times the original focal length!

The TEE Doubler and the TEE Tripler fit between the T-Mount and the Lens Barrel. They do NOT go between the camera and the bayonet and are NOT to be used with Exakta lenses with fixed bayonet mount.

**Tee Doubler \$9.45 + 50¢ Shipping Charges**

**Tee Tripler \$11.95 + 50¢ Shipping Charges**

**Case, each 95¢**

**Combination:**

**Tee Doubler, Tee Tripler, Two Cases, \$18.50 + 75¢.**

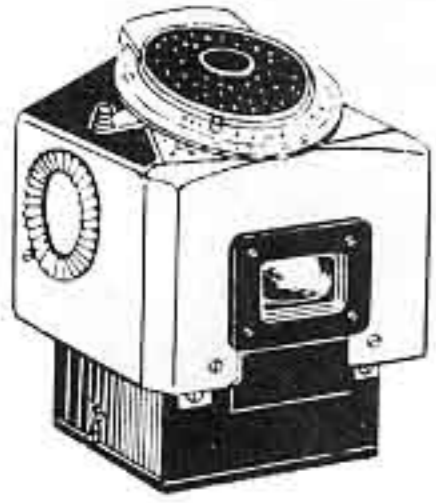

## New Model Travemat Through-the-Lens BTL Light Meter Prism System

When the first model Travemat was announced it was something of a mystery to many Exakta Owners. By now, just about everybody knows that it measures the light AFTER it has passed through the lens and that it sees exactly the same amount of light as the film. However, there are quite a few things about this system that many Exakta users have not quite realized.

Let's take regular scenic photography first. The Travemat has two independent sensors. It measures the light just below the horizontal center line and slightly to the right and left of the vertical center line. The result is an intelligent reading of the light intensity, totally eliminating the glare from the sky. Experienced photographers point a hand-held meter downward for exactly the same reason. You "point" the Travemat exactly at the scene you want to photograph and its "brain" does the "thinking" for you. The Travemat is a true Point-and-Shoot Meter.

Where the Travemat really shines is in all types of photography where you ordinarily would have to use Exposure Compensation. Say, you shoot with a Polarizer on the lens. By what factor do you have to increase the exposure? Forget it! The light that goes through the lens has already passed through the Polarizer and the Travemat "sees" only the usable light just as the film does. It does not care why there is less light. It measures what it sees. You don't care either: You completely IGNORE all compensating factors. You shoot as if you had never heard of a filter factor. The Travemat has done all the "compensating" for you. That goes for any filter factor. With the Travemat you just ignore it.

Here's something else: Has it ever occurred to you that not all your lenses may be calibrated correctly? How can you know whether your lens is really F5.6 when you set it at F/5.6? Anyway, F/5.6 is not an absolute figure as far as light transmission is concerned. It is merely a mathematical ratio of the diameter to the equivalent focal length. Certain standards have been adopted to make F stops less arbitrary but the fact remains that you cannot check the accuracy of the F stop settings on your lens. The Travemat (and you) couldn't care less. The Travemat does not see the markings on your lens. It sees the light that passes through your lens. While the two values might vary considerably, the only true value is the one the meter sees! All of a sudden, your exposures are correct. You may surprise yourself by getting perfect shots from lenses that used to give you blueish pictures before you used the Travemat.

Of course, the Travemat is totally indispensable in Macro Work. Remember what you had to go through, to compute your exposure? Extension, magnification, filter factors and on and on. You had to be an expert evaluator of the various influencing factors and you had to be able to translate all these factors into exposure speed and F stop adjustments. And you had to be a mathematician. Now you let the Travemat do it all for you. Concentrate on taking your Macro Photographs instead of wasting most of your time figuring and calculating and wondering where you made your mistake. The Travemat takes ALL variables into consideration. Your exposures will be correct.

Operation of the Travemat is simplicity itself: After you set the ASA rating of the film and the shutter speed, you watch the indicator needle (which you see in the viewfinder) as you vary the lens opening. As soon as the needle shows between the brackets, you shoot.

No matter what kind of shots you take, the Travemat will make picture taking easier and foolproof, even under the most difficult conditions. What's more, every single one of your shots will be perfect.

We supply the Latest Model Travemat BTL System PentaPrism, with Fresnel Lens and MicroGrid for \$49.50 + 1.35 Shipping Charges.



## Hugo Meyer (Meyer Optik) Gorlitz 35mm F4.5 preset Primagon.

Full 65 degree coverage — sharp from corner to corner — brilliant color rendition — flat, distortionless image — smooth-acting preset diaphragm stops down to F22. Weighs only 6 oz. and is only 1 $\frac{3}{4}$  inches long — focuses to less than 1 $\frac{1}{2}$  ft. An excellent wide angle lens!

Don't miss this wonderful buy at

**19<sup>95</sup>** Case \$3.95  
plus 85¢ shipping



## Low Cost Life Insurance for your Lenses

If you love your lenses, protect them from all hazards and prolong their useful life. Our new Lens Pouches are soft as a glove, lined with luxurious plushy velvet, and have drawstrings for quick and easy opening and closing. Less bulk than ordinary lens cases. More "cuddle" for your fine lenses. Also recommended for delicate accessories. Three sizes: Small \$2.85 + 25¢, Medium \$3.85 + 25¢, Large \$3.85 + 25¢.

## Prices Reduced on these Always-Welcome Stocking Stuffers

Photographer's Travel Book . . . . .	\$1.95
Set of 6 Original Color Slides by Earl Seymour . . . . .	\$1.95
Depth-of-Field Book . . . . .	75¢
Film Cutting Scissors . . . . .	\$1.25
Betta Vue Illuminated Slide Viewer . . . . . 2 for	\$2.95
Miniature Tool Set . . . . .	\$1.95
Rewind Handle . . . . .	\$1.45

# Seymour's Inst-A-Dapters

At last there is a solution to a vexing problem: How to use custom screw-in accessories on lenses with DIFFERENT threads. Most Exakta Owners have a good selection of 49mm Accessories because many Exakta Lenses have a front thread of 49mm. What happens when you buy a lens with, say, a 54mm thread? No need to buy all new accessories: Seymour's new Inst-A-Dapters will let you use your 49mm Accessories on your new lens with 54mm front thread. Seymour's Inst-A-Dapters are of special ultra-thin construction to eliminate vignetting. Order any combination shown below:

Model No.	Has Male Thread:	Has Female Thread:
IA-4952	49mm	52mm
IA-4955	49mm	55mm
IA-5249	52mm	49mm
IA-5254	52mm	54mm
IA-5449	54mm	49mm
IA-5452	54mm	52mm
IA-5455	54mm	55mm
IA-5549	55mm	49mm
IA-5552	55mm	52mm

## Price Reduction

Seymour's  
Inst-A-Dapters **2<sup>75</sup>** + 25¢

Any 3 for **6<sup>95</sup>** + 50¢



**+10**

### Auxiliary Close-Up Lens

for ultra close-up work  
No exposure increase!  
Series VII

**4<sup>95</sup>** + 25¢

Ultra Sharp  
Enlargements  
with the new



### Micro-Print

A precision instrument designed for the professional photographer but now priced for the amateur. Works like a microscope: You actually focus on the microscopic grain of the film. If you make your own enlargements you cannot do without this instrument.

Micro-Print  
Enlarging Magnifier **4<sup>95</sup>** + 95¢ Postage  
16 Stock No. C-21751

# "Toshiba"

You may have seen the name Toshiba on an imported television set. If you are a research scientist you may have seen it on an Electron Microscope. But if you have been to Japan, you know that Toshiba is the "General Electric" of Japan, one of the world's largest manufacturers of electric and electronic equipment from Transistor Radios to Military Radar Systems. Pronounce it TOE-shee-bah, stressing the "TOE".

Toshiba has just come out with a new Cadmium Sulfide (CdS) Exposure Meter, the brain child of a giant company, the PE-1.

The world's film manufacturers will run out of film speeds before the PE-1 will: ASA 6 to ASA 6400! Your camera will run out of F stops before the PE-1 will: F/1 to F/32! And try to match its range of speeds: 8 minutes (not seconds) to 1/8000 sec.! Really easy to use: "One Touch" Operation! And you hardly know you are carrying it: just 3 1/2 ounces! And most important: regardless of price, the Toshiba PE-1 is the most accurate meter in our stock.

Why do we tell you all about this meter which sells for less than \$20 when we have been doing quite well, thank you, selling other meters for over \$50.00? Sure, we like to sell high-priced equipment with a healthy mark-up. But — when we like a piece of equipment, we say so. True, we cannot make \$20 on the Toshiba PE-1 because we sell it for \$16.95. But it's such a fine meter that it would not be fair to our customers to hide it. We know it's good. It is your best investment in picture quality. Buy it!

Toshiba PE-1 Ultra Sensitive CdS Meter, Seymour-priced at \$16.95 plus 95¢ postage, and with every meter we will give you the tiny battery and the case free. No matter how many meters you now have, order the Toshiba — on our recommendation!



Toshiba PE-1  
Seymour Special **16<sup>95</sup>** + 95¢ Postage  
Battery & Case included

### Ultra Sensitive CdS Meter Toshiba PE-1

"One Touch" Operation

ASA 6—6400  
F/1 to F/32  
8 minutes to 1/8000 sec.!

Weighs only 3 1/2 oz.

Truly ACCURATE!

### Close-Up Set Combination

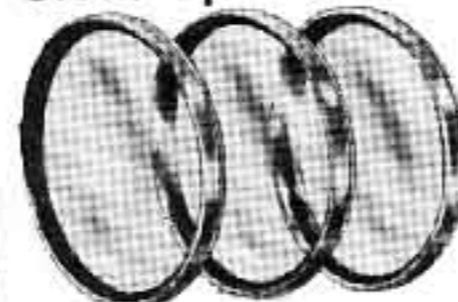

+1  
to  
+6

The Set consists of 3 high quality coated optical lenses in threaded chrome mounts. Use them singly or in combination, from Plus One to Plus Six.

Be sure to mention Model wanted: Model VII fits any Series VII Filter Adapter. Model 49 screws directly into Biotar, Auto-Tessar, Pancolar, Xenon, Quinon, Quinaron, and all lenses with this thread. Leather Case included.

**12<sup>50</sup>**  
Plus 85¢



## Slide Duplicator

Use it with Extension Tubes and your normal lens. Fits into your Series VII Filter Adapter. Slip slide into special holder. Diffusion glass prevents hot spot. Use any light source, even daylight. Helical Focusing Mount permits exact positioning of slide for correct focus. Use it to make duplicates of all your good slides. Also ideal for making black-and-white negatives from color slides.

Series VII  
Slide Duplicator  
Stock No.  
21705

**12<sup>50</sup>** + 75¢ Postage



## REPAIRS

As Exakta Specialists we are fully equipped to handle all repairs on Exakta cameras, lenses and accessories. No "Jacks-of-All-Trades" our mechanics are specialists on Exaktas. Please don't send us your Rolleiflexes or Movie Cameras for repair. But we will take care of all your Exakta adjustments and repairs. Original parts and factory recommended methods are used. Seymour-repaired Exaktas are guaranteed for one whole year. Want an estimate first? Sure thing. Send the equipment, attach a tag to it and mark it "Estimate Only." No obligation.

Sometimes people write and ask whether we repair only cameras bought from Seymour's. Perish the thought! All Exaktas are our babies, regardless where purchased. Whenever you need help, Seymour's is ready to give it. As long as it is an Exakta, we are always ready, willing, AND ABLE to cure what ails it.

Our charges are reasonable. Repair charges are based on the time consumed and experts don't have to fumble around trying to find a way to repair a camera. Don't forget that we LIVE with Exaktas: we know them inside out!

In case we haven't repeated it often enough:

**15 DAYS TRIAL  
AND MONEY BACK  
on every item in this folder**



## Rokunar Lenses



Rokunar (of "Sharp-as-a-Rokunar" fame) has extended its line again. Rokunar Lenses are prized by their owners for their superb resolving power and 100% correct color correction. Every Rokunar proudly carries its name. You can now choose from this impressive list:

28mm F2.8 fully automatic Rokunar 69.50 + 1.25 (Case \$3.95)  
 35mm F2.8 fully automatic Rokunar 59.50 + 1.25 (Case \$3.95)  
 105mm F2.5 fully automatic Rokunar 59.50 + 1.25 (Case \$4.95)  
 135mm F2.8 fully automatic Rokunar 59.50 + 1.25 (Case \$4.95)  
 200mm F3.9 fully automatic Rokunar 79.50 + 1.35 (Case \$5.95)  
 200mm F4.5 preset Rokunar . . . . . 49.50 + 1.25 (Case \$4.95)  
 300mm F5.5 fully automatic Rokunar 89.50 + 1.65 (Case \$6.95)  
 85mm to 205mm fully automatic  
 Zoom Rokunar 139.50 + 1.95 (Case \$7.85)

**New! Ingenious!**  
**Internal Automatic Elongar**  
**Tele Converter couples internally.**  
**Doubles Focal Length.**  
**No outside rods.**  
**Optically matched to Rokunar Lenses**  
**a genuine Rokunar Product.**  
**Only \$19.50**

## Master Showman Projection Pointer

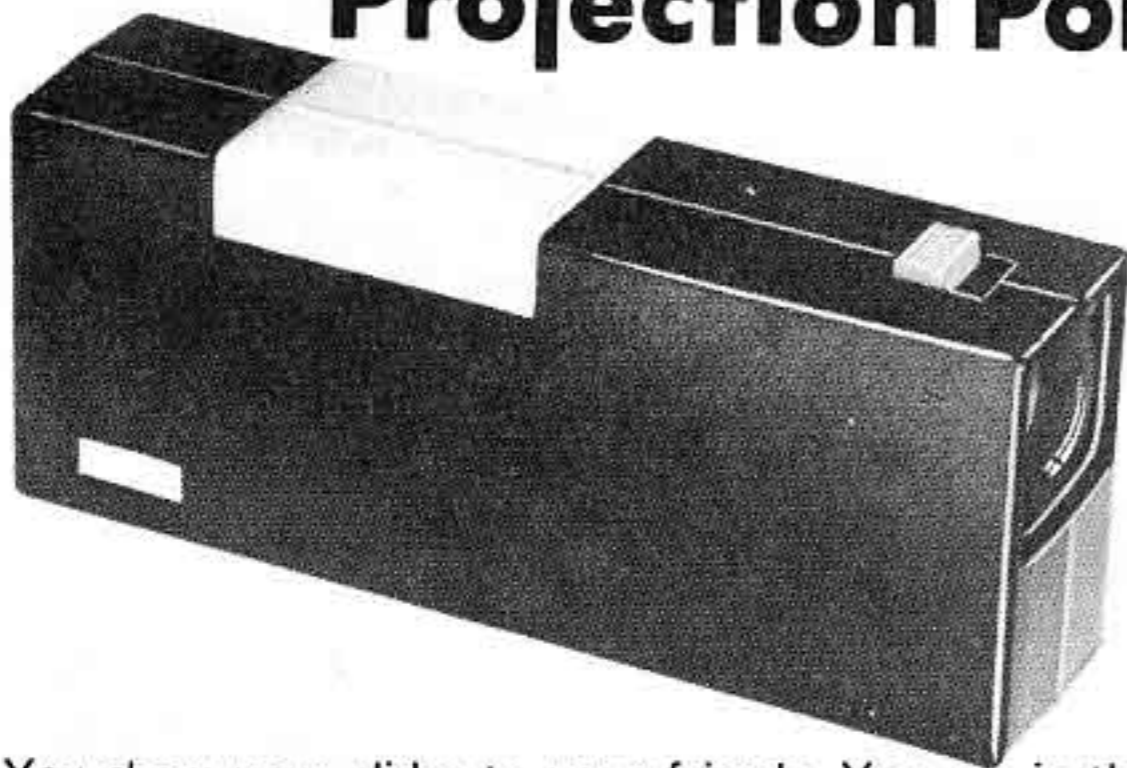

You show your slides to your friends. You are in the middle of your slide show. Now you want to point out a detail on the screen. What do you do? Walk to the screen, your shadow nicely blocking the slide and point out the detail? No! You project a brilliant white arrow with the new Master Showman Projection Pointer right from the back of the room. Adds a professional touch to your slide show.

The new Master Showman Projection Pointer is a radical departure from old fashioned projection pointers. The design sports an ebony black square (yes, square!) housing. The Battery Compartment slides open for quick change. The Bulb Compartment snaps open and shut for easy replacement, even during a show! An opal translucent part of the housing sheds unobtrusive subdued light for slide selection, reading of captions, change of magazines or adjustment to the projector. No more annoying switching on of bright lights and no more fumbling in the dark.

The Master Showman Projection Pointer superimposes a sharp arrow on the screen. One-finger on/off button. One-finger focusing button adjusts the sharpness of the arrow according to the distance from the screen. Effective even in large rooms.

Add the finishing touch to your slide shows with the new Master Showman Projection Pointer, Seymour priced at only \$6.95 + 45¢ Shipping. (Batteries and Special Bulb included).

## 200mm F4.5 preset Rokunar

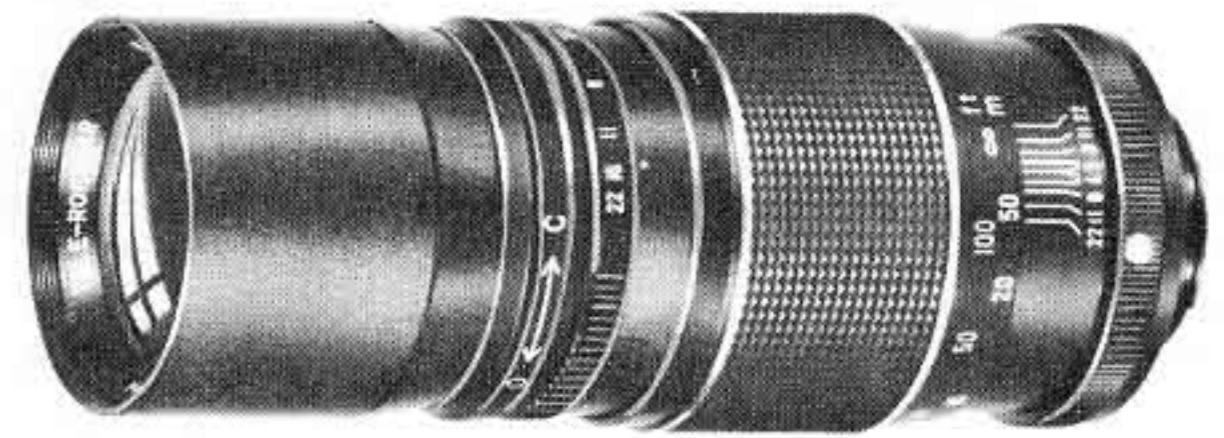

Rokunar brings you the new 200mm F4.5 preset Tele-Rokunar!

Gone are the days when 200mm Telephoto Lenses were heavy, clumsy, large Big Berthas. In a major break-through in optical design, Rokunar (of "Sharp-as-a-Rokunar" fame) threw the excess size, weight, and bulk over board. The new 200mm F4.5 preset Tele-Rokunar is about the size of a 135mm lens. In fact, it is smaller than the 135mm F3.5 Meyer Primotar! Fully preset, smooth-acting diaphragm. Ultra high correction for minute detail. Cuts distance by 75 per cent!

The 200mm F4.5 preset Tele-Rokunar is unbelievably low Seymour-priced at a mere \$49.75 + 4.45 for the case and \$1.25 Shipping Charges.

Small in size, light in weight, and sharp as a Rokunar! Try it on Seymour's Fifteen-Day Money-Back Trial basis.

## Important! Read this: Last-Minute Specials

These Great Buys arrived just before the printing deadline. They would have deserved much more prominence but we no longer had the space in this issue, nor were we able to show illustrations. But we did want to include them in this Newsletter because they are excellent buys. They deserve your attention:

100mm F2.8 automatic Meyer Trioplan \$39.95 + 95¢  
 250mm F5.5 preset Meyer Tele-Megor \$39.95 + 1.25  
 300mm F5.6 preset Tele-Coligon . . . \$49.95 + 1.45  
 Enlarger-in-a-Suitcase, for 35mm film \$89.50 + 2.85

## New! Master Showman II

The Master Showman II Projection Pointer plugs into AC House Current. Ultra brilliant projected arrow.

Master Showman II for AC Operation . . \$19.50 + 45¢

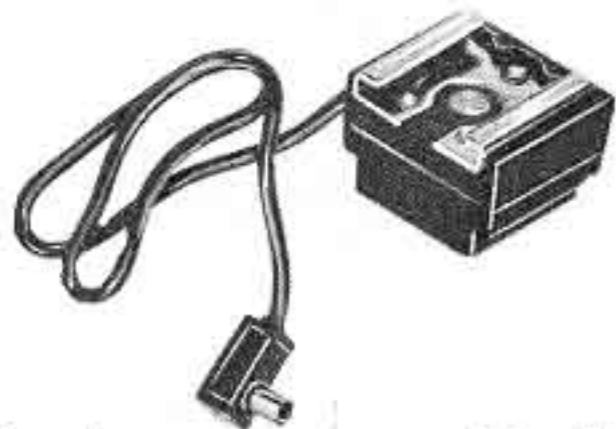

**New! Hot Accessory Shoe Conversion Assembly.**

Convert your Exakta for flash and strobe units which require a "hot" shoe. Slides into your regular accessory shoe. Plugs into flash or strobe outlet of camera and supplies synch current directly to your flash. Regular Accessory Shoe (top or bottom model) also needed.

**Hot Shoe Conversion Assembly \$2.85 + 15¢**



**New! PCTwin Outlet Converter.**

Now, for the first time, you can fire two flash or strobe units simultaneously without the twin hot bracket. Professionals use two or more flash units to eliminate ugly shadows and to spread the light more evenly. They use multiple lights for close-ups, table tops, copying, etc. Now you can fire two or more lights without costly slave units, electronic trippers, or solenoids. Plug the PC Twin into the camera and the lights into the PC Twin. Can be used in Multiple Set-ups for 3, 4, or more lights. Sold only in sets of 2.

**2 PC Twins \$1.85 + 15¢**



**New! All Metal Slide Sorter**

A new idea in slide sorting. Slides sit on special metal rails and are easily moved around. Cannot slide or fall off. Arrange them and rearrange them for the proper projection sequence. You can select your best slides for projection because you see them all at the same time. An inexpensive yet indispensable accessory. Buy several for yourself and more as welcome gifts.

**Metal Slide Sorter \$3.95 + 55¢**  
**3 for \$10.75 + 65¢**  
**6 for \$18.95 + 95¢**



**New! New DeLuxe Model Twin Cable Release Assembly.**

Newly designed Double Cable Tripping Unit to retain the automatic feature of your lenses on bellows, tubes, etc. Easily adjusts to "throw" of different lenses.

**DeLuxe Model Twin Cable Release Assembly \$7.75 + 25¢**

**New! Accessory Shoe for Permanent Mounting.**

Attaches to ANYTHING by means of two screws. Attach it to the camera, make your own flash brackets, etc. Unlimited uses. Sold only in sets of 3.

**3 Permanent Mount Shoes \$1.85 + 15¢**



**Automatic Extension Tubes for Exakta.**

Set consists of 3 self-contained tubes. All three have the male and the female Exakta Bayonet. Each tube can be used independently by itself or in any combination. Rods couple to automatic lens and shutter release of camera and your automatic lenses remain automatic for close-up work.

**Automatic Extension Tube Set for Exakta \$19.95 + 65¢**

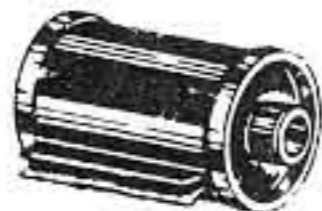

**Reloadable Cassettes**

This new German Cassette has screw top. Stock up at these low prices:

**10 for \$ 3.50 + 35¢**  
**25 for \$ 6.95 + 45¢**  
**100 for \$24.50 + 65¢**



**New! Flat Camera Brush.**

Indispensable for eliminating dust inside your camera, on your fine lenses and other equipment. Finest Camelshair.

**Flat Camera Brush \$1.85 + 15¢**

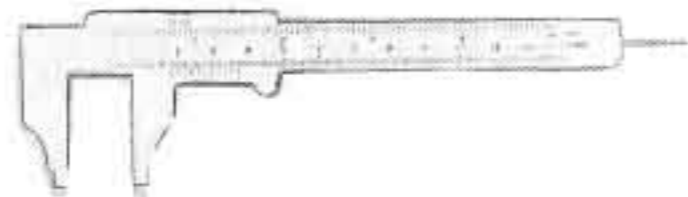

**New! German Precision Calipers**

Measure Lens Thread Diameters, etc. These calipers measure inside diameter, outside diameter, depth. Precision made in Germany.

**Precision Calipers \$2.85 + 15¢**

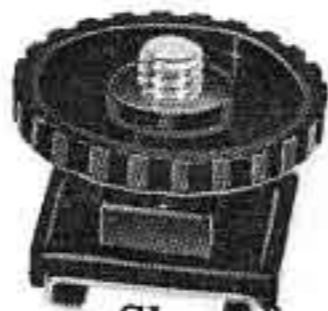

**New! Accessory Shoe for BOTTOM of Camera.**

The new BTL Systems pose a problem: the regular accessory shoe can no longer be used. Who has solved the problem? Seymour's-Exakta, of course! We have devised an Accessory Shoe which attaches to the BOTTOM of the Camera!

**Bottom Accessory Shoe \$1.85 + 15¢**



**New! Roller Squeegee.**

New heavy duty model. For flawless high-gloss finish of ferrotyped prints. 5 inches wide.

**Roller Squeegee \$2.45 + 25¢**



**New! German Shoulder Pad.**

Prevents camera strap from sliding off your shoulder. Leather top, rubber friction-hold bottom. Also prevents strap from hurting your shoulder. Sold only in sets of 3.

**3 Shoulder Pads \$1.85 + 15¢**



**New! Braided Leather Neckstrap**

Has Safety Catches. Holds camera safely and securely. Elegant. Supple. Pleasant to wear. No chafing.

**Braided Neckstrap \$2.85 + 15¢**



**New! Swivel Brush.**

Extra wide. Adjust angle of handle and get at difficult-to-reach parts of cameras, lenses, projectors, etc. First Quality Pure Camelshair.

**Swivel Brush \$2.45 + 15¢**



**New! German Precision Screwdriver Set.**

If you have to make quick adjustments on lenses, etc. use these precision tools. Tempered steel Blades. Four different sizes plus sure-grip handle. Fits even tiny screws. Cuts your cost of maintenance. Saves its cost the first time you use it.

**Screwdriver Set \$1.85 + 15¢**

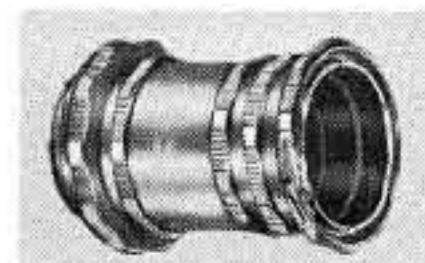

**Exakta Extension Tubes**

Set consists of 5 parts: Male Exakta Bayonet, Female Exakta Bayonet, one tube each of 30mm, 15mm, and 5mm length.

**Original Ihagee, Set \$11.95 + 35¢**  
**Budget Set \$7.65 + 35¢**



**Two-in-One Extender**

5mm total extension. Bridges gap between focusing range of lens with and without tubes. Has both the male and the female Exakta Bayonet machined INTO EACH OTHER. Very ingenious and effective.

**Two-in-One Adapter \$8.95 + 25¢**



**Pneumatic Air Cable**

Twenty feet remote control Air Release. Neoprene Tubing is impervious to heat, humidity. Comes rolled up on roller. Has hand bulb, air cylinder which activates the tripper.

**Pneumatic Cable \$5.95 + 25¢**

**Short Air Cable**

Serves best to eliminate camera shake because the air tubing does not transmit vibrations. 40 inches long. No roller but otherwise similar to 20-foot model.

**40-Inch Air Cable \$4.95 + 25¢**



**Blower Brush**

Hand Bulb, metal sheathed extending camelshair brush which retracts into body of bulb. Hinged dust cover to protect hair from dust. Gentle air stream loosens dust particles. Bristles brush them away. An absolute Must for delicate glass surfaces.

**Blow Brush \$1.95 + 25¢**

**"Shortie" Cable Release**

Six inches long. Cloth Covered.

**Six-Inch Cable, Pak of four \$1.95 + 15¢**

**Vinyl Cable Release**

Twenty inches long, professional type, has butterfly handgrip, locking device.

**Vinyl Cable \$2.95 + 25¢**



### Rubber Sunshades

A new design which permits folding the sunshade back over the lens when not in use. Finest quality and fully as effective as the metal shades. Comes in Ser. VII and in mm sizes. State sizes needed.

Rubber Lens Shade \$4.50 + 25¢

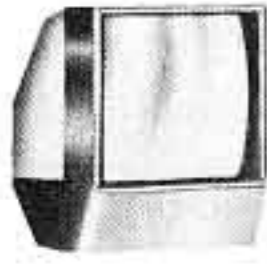

### Betta Vue Illuminated Hand Viewer

Takes all 35mm slides, also half frame and super slides. Shaped like a miniature TV Set. Light goes on automatically when you insert the slide and goes out when you remove the slide. Battery operated, the Betta Vue goes with you wherever you want to show off your slides. Set of batteries free.

Betta Vue Slide Viewer \$1.95 + 35¢



### Metal Lens Caps, Screw-in

These come in Ser. VII or custom sizes

\$1.95 + 15¢. Three for \$4.95 + 25¢

**Body Dust Cap for Exakta Body** Bayonets into lens mount to protect the mirror and the shutter when you carry the body without lens.

\$1.95 + 15¢. Three for \$4.95 + 25¢

**Rear Lens Cap, Bayonet Fitting.** Dustproof. \$1.95 + 15¢. Three for \$4.95 + 25¢



**Exakta Accessory Shoe** fits on top of prism (not for BTL)

Original Ihagee \$3.95 + 25¢  
Independent Make \$1.95 + 15¢



### Eyecup for Prism

swivels for horizontal or vertical shots. Has Retaining Ring for Prescription Lens.

Original Ihagee \$5.50 + 25¢



### Giant Release Knob

Also called Giant Release Button. Allows fumble-free soft release of the shutter. A great help for rock-steady handheld pictures.

Giant Button \$1.95 + 15¢



### Exakta Rewind Handle

for Models VX and VXIIa. Keeps Rewind Clutch Depressed. Makes rewinding very easy. Not needed on models with built-in rewind handle (VXIIB and later).

Rewind Handle \$2.85 + 15¢



### Chrome Neckchain

Beautiful Chrome snakechain. Locking lugs. Round: does not cut into your neck.

Chrome Neckchain \$3.25 + 15¢

### Leather Neckstrap

Flat Leather. Locks.

Leather Neckstrap \$1.95 + 15¢

### Braided Leather Neckstrap

Beautiful braided leather. Round to protect your neck or shoulder. Extra heavy-duty locking lugs.

Braided Leather Strap \$2.95 + 15¢



Control the Speed of your Film with a

### NEUTRAL DENSITY FILTER

At times it becomes important to increase the exposure WITHOUT stopping down the lens. The Neutral Density Filter adjusts the film speed to your needs. It does NOT change or alter the colors.

### Neutral Density Filter

Series VII \$5.59 + 25¢

### Soft Focus Disc.

Did you ever hate your best lenses because they revealed every tiny wrinkle in your portraits? Did you ever wish for a soft rendition of a beautiful landscape? Of course you did! Here is the solution: the new Soft Focus "Filter." It softens harsh lines and harsh light. Try one!

Soft Focus Disc, Ser. VII \$5.95 + 25¢

### Grid Filter Disc.

Puts tiny sparkling "stars" on every light in your pictures. Adds romantic sparkle to otherwise dull shots. Especially dramatic in shots "against the light." Equally effective for color and black-and-white. Try one!

Grid Filter Disc, Ser. VII \$5.95 + 25¢

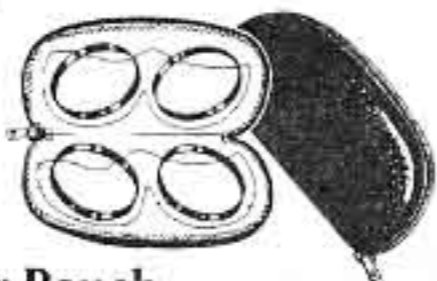

### Filter Pouch

This beautifully designed Filter Pouch protects your delicate filters from dust and scratches. Four filters are in full view. Filter Pouch has smooth zipper, clear transparent "windows."

Zippered Filter Pouch \$1.95 + 25¢



### Plus Ten

Auxiliary Close-Up Lens for ultra close-up work. High Quality coated optical lens. No exposure increase. Series VII Drop-in mount. Requires Filter Adapter.

Ser. VII Plus Ten Lens \$4.95 + 25¢

### Combination Close-Up Set

Builds up from +1 to +6.

The Set consists of 3 high quality coated optical lenses in threaded mounts. Use them singly or in combination: they screw into each other. Unbroken Power Range from +1 to +6. Available in Series VII or in 49mm Thread Size. State preference. Leather Case included at no extra charge.

### Combination Close-Up Set

\$12.50 + 35¢



### Series VII Filter Adapters

Use with Series VII Filters, Grid Discs, Soft Focus Discs, etc. Available for lenses with front diameter of 46mm, 49mm, 52mm, 54mm, 55mm, 58mm.

Ser. VII Filter Adapter \$4.50 + 25¢

### 49mm Series Six Adapter

Do you want to use inexpensive Ser. VI filters and accessories on your lenses with 49mm diameter? This special "step-down" adapter makes it possible.

Ser. VI/49mm Adapter \$3.95 + 25¢



### Sunshades

Series VII, fits adapter \$4.95 + 25¢  
49mm, fits lens, \$4.95 + 25¢

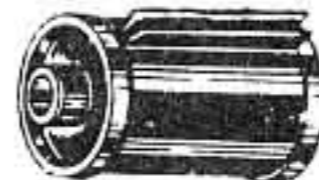

### Reloadable Cassettes

Load your own film cassettes at a fraction of the cost of factory loaded cartridges. Use the cartridges over and over. Top unscrews for easy assembly. Made in West Germany.

Cassettes, Pak of Ten \$3.50 + 25¢  
25 for \$6.95 + 35¢  
100 for \$24.50 + 45¢

### Miniature Tool Kit

Make simple emergency repairs or adjustment on location. Consists of tiny hammer, small screwdriver, small Phillips screwdriver, piercer or punch, and a small auger to start screws in wood. All tools fit a small handle which locks them securely in a tiny precision chuck.

Miniature Tool Set \$1.95 + 35¢



### Eyelevel Finder

Original Ihagee PentaPrism without Focusing Insert \$14.50 + 65¢  
with Fresnel/MicroGrid \$18.50 + 65¢

### Waistlevel Finder

Original Ihagee Hooded Reflex Finder with Magnifier for critical focusing without Focusing Insert \$11.95 + 65¢  
with Fresnel/MicroGrid \$16.50 + 65¢

### Focusing Insert

Combination Fresnel ViewingScreen with MicroGrid Rangefinder and finegrain Groundglass Ring, Original Ihagee \$7.50 + 35¢  
Independent Make, \$5.95 + 35¢  
Groundglass with MicroGrid \$4.95 + 35¢



### Bouncelight Swivel Joint

Converts any flash or strobe into a bounce gun. Also very useful for aiming the flash. Omni-directional. Chrome-on-brass construction.

Bounce Swivel \$3.95 + 25¢



### Reverse Adapters

Indispensable for ultra close-up work with normal lenses. These come in Series VII with Exakta Bayonet or in 49mm with Exakta Bayonet. State preference.

Reverse Adapter \$3.95 + 25¢



### Twin Flash Bracket

Mounts and fires two flashguns or strobes. Internally wired. Plugs into flash outlet of camera and the two guns plug into the outlets of the bracket. Two flash or strobe guns soften the light, eliminate harsh shadows, flatter the subject and, best of all, double the light.

Twin Flash Bracket \$4.95 + 45¢

### Micro-Print

Do you do your own enlarging? Here is an instrument which makes it impossible to get out-of-focus enlargements. It works like a microscope: You place it on the easel of your enlarger, turn on the enlarger and actually focus on the microscopically small grain of the film emulsion. Focus is not affected by the sharpness of the negative.

MicroPrint \$4.95 + 95¢

**SEYMOUR'S**  
The Exakta Specialists

# SEYMOUR'S - EXAKTA

The World's Only *Exclusive Exakta Dealer*

350 W 31 St., New York, N. Y. 10001

Exakta Specialists for over 20 Years

## Net Price List

### EXAKTA CAMERAS

Latest 1971 Exakta RTL, with TTL Coupled Metering System, Combination Fresnel Viewing Screen and MicroGrid Focusing Aid, fully automatic F1.8 Meyer Optik Oreston Lens, \$199.50 + 17.85 for the Case with Extra High Top and \$1.95 Shipping Charges.

Exakta VX-1000TL, Original Ihagee PentaPrism, Combination Fresnel Viewing Screen and MicroGrid Focusing Aid, fully automatic genuine Jena 50mm F2.8 Tessar Lens, \$87.50 plus \$7.85 for the case and \$1.95 Shipping Charges.

Same, but with F2.8 fully automatic Meyer Optik Domiplan, \$79.50 plus \$7.85 for the case and \$1.95 Shipping Charges.

Same, but with F/2 fully automatic genuine Jena Pancolar \$99.50 plus \$7.85 for the case and \$1.95 Shipping Charges.

Same, but with fully automatic Schneider Xenon F1.9 \$144.50 plus \$7.85 for the Case and 1.95 Shipping Charges.

Exakta VX-1000TL/BTL, with New Model Travemat Behind-the-Lens Metering Prism with Combination Fresnel Viewing Screen and MicroGrid Focusing Aid with F2.8 fully automatic Meyer Optik Domiplan \$109.50 plus \$17.85 for the special Case with Extra High Top and \$1.95 Shipping Charges.

Same, but with fully automatic F2.8 genuine Jena Tessar \$117.50 plus \$17.85 for the case and \$1.95 Shipping Charges.

Same, but with fully automatic F/2 genuine Jena Pancolar \$129.50 plus \$17.85 for the case and \$1.95 Shipping Charges.

Same, but with fully automatic Schneider Xenon F1.95 \$174.50 + 17.85 for the Case and 1.95 Shipping Charges.

Cases come factory packed with cameras. Purchase of case is mandatory.

Exakta VX-500 with Model C Hooded Reflex Finder with Magnifier for critical focusing, with captive fine-grain groundglass with F2.8 fully automatic Meyer Optik Domiplan \$49.95 plus \$7.85 for the case and \$1.95 Shipping Charges.

Same, but with F2.8 fully automatic genuine Jena Tessar \$57.95 plus \$7.85 for the case and \$1.95 Shipping Charges.

Same, but with F/2 fully automatic genuine Jena Pancolar \$69.95 plus \$7.85 for the case and \$1.95 Shipping Charges.

Exakta Bodies, less lens and finder:

Exakta VX-1000TL \$64.50 + 1.95 Shipping Chgs.

Exakta VX-500 \$39.95 + 1.95 Shipping Chgs.

Case, optional \$7.85

Exakta Bodies, with original Ihagee PentaPrism and Combination Fresnel Viewing Screen and MicroGrid Focusing Aid:

VX-1000TL \$78.50 + 1.95 Shipping Charges

VX-500 \$54.50 + 1.95 Shipping Charges

Case, optional, \$7.85

Exakta BTL Bodies, with New Model Travemat Behind-the-Lens Metering Prism, without lens:

VX-1000TL/BTL \$108.50 + 1.95 Shipping Charges

VX-500 BTL 84.50 + 1.95 Shipping Charges

Special Case with Extra High Top \$17.85 (optional)

### STANDARD FOCAL LENGTH LENSES

50mm F2.8 fully automatic Meyer Optik Domiplan \$19.85 + 95¢

50mm F2.8 fully automatic genuine Jena Tessar \$27.50 + 95¢

50mm F/2 fully automatic genuine Jena Pancolar \$39.95 + 95¢

50mm F1.9 fully automatic Schneider Xenon . . \$89.50 + 95¢

### VIEW FINDERS

Hooded Reflex Finder, Model C

with captive finegrain groundglass . . . . . \$ 8.95 + 65¢

Hooded Reflex Finder, Model N,

without Insert . . . . . \$11.95 + 65¢

with finegrain groundglass . . . . . \$14.95 + 65¢

with Combination Fresnel Screen and MicroGrid \$16.50 + 65¢

Eyelevel PentaPrism, Original Ihagee

without Insert . . . . . \$14.50 + 65¢

with Combination Fresnel Screen and MicroGrid \$18.50 + 65¢

New Model Travemat BTL System with MicroGrid \$49.50 + 95¢

### FOCUSING SCREEN INSERTS

These Screens fit the PentaPrism, the new Model Travemat, the Examat, and the Model N Waistlevel Finder:

Finegrain Groundglass . . . . . \$3.95 + 35¢

Combination Fresnel Screen/MicroGrid, best . . . \$7.50 + 35¢

Groundglass with MicroGrid . . . . . \$4.95 + 35¢

Split Image Rangefinder Insert . . . . . \$6.95 + 35¢

### CAMERA CASES

Standard Case, Non-detachable front . . . . . \$ 7.85 + 95¢

Black Case, detachable front, most popular case . . 9.85 + 95¢

DeLuxe Case, detachable frt., Metal Trim . . . . . 14.95 + 95¢

Black DeLuxe Case with Extra High Top, with detachable front (takes camera with BTL Meter) 17.85 + 95¢

## Shipping Charges

*Some customers write and ask whether the Shipping Charges shown in our listings are just for the Postage: "How much do I have to add for handling, packing, shipping containers, insurance, etc.?" You don't have to add anything. The amount shown under "Shipping Charges" includes everything.*

## WIDE ANGLE LENSES

35mm F4.5 preset Meyer Optik Primagon . . . . .	19.95 + 95¢
35mm F3.5 preset Terragon . . . . .	19.95 + 95¢
35mm F2.8 fully automatic Rokunar . . . . .	59.50 + 1.25
35mm F3.5 fully automatic Steinheil Culmigon . .	44.50 + 95¢
28mm F2.8 fully automatic Rokunar . . . . .	69.50 + 1.25
35mm F2.8 fully automatic Jena Macro Flektogon with self-compensating diaphragm . . . . .	89.50 + 1.25
25mm F/4 fully automatic genuine Jena Flektogon . . . . .	\$89.50 + 1.25
40mm F2.8 Macro—Kilar, reg. \$150.00, Special Sale . . . . .	\$89.50 + 1.25

## TELEPHOTO LENSES from 85mm to 135mm

85mm F1.9 preset Super Coligon . . . . .	44.50 + 1.25
100mm F2.8 fully automatic Meyer Optik Trioplan . . . . .	\$44.50 + 95¢
105mm F2.8 fully automatic Rokunar . . . . .	59.50 + 1.25
135mm F3.5 preset Taika Doryt Telephoto Lens .	\$24.50 + 95¢
135mm F3.5 fully automatic Schneider Isco Telephoto . . . . .	\$49.50 + 95¢
135mm F2.8 preset Schneider—Isco Telephoto .	\$39.95 + 95¢
135mm F2.8 fully automatic Steinheil T/Quinar .	89.50 + 1.25
135mm F2.8 fully automatic Rokunar . . . . .	69.50 + 1.25
135mm F/4 fully automatic Jena Sonnar . . . . .	79.50 + 1.25
135mm F2.8 fully automatic Steinheil Macro-S .	159.50 + 1.25

## TELEPHOTO LENSES, 150mm and longer

150mm F5.5 preset Meyer Optik Tele-Megor . . . .	19.95 + 95¢
180mm F2.8 fully automatic genuine Jena Sonnar	159.50 + 2.95
200 F4.5 preset Tele-Rokunar . . . . .	49.50 + 1.25
200mm F3.9 fully automatic Rokunar . . . . .	79.50 + 1.35
300mm F5.6 Preset Rokunar . . . . .	49.50 + 1.45
300mm F5.5 fully automatic Rokunar . . . . .	89.50 + 1.65
MTO MIRROR LENS, 500mm F/8, with 4 Filters . . . . .	\$269.50 + 2.65

## ZOOM LENSES

85mm to 205mm F3.6 fully automatic Rokunar .	139.50 + 1.95
--	---------------

## MACRO and CLOSE-UP EQUIPMENT

### Exakta Bellows

Twin-Rod Models with geared Rack-and-Pinion Focus Model TW-5 with full 5-inch Extension	17.95 + 95¢
Model TW-7, Extra Long 7" (180mm) Extension .	19.95 + 95¢
Monorail Model with geared Rack-and-Pinion Focus Model MR-5, Full 5-inch Extension . . .	13.95 + 95¢

### Extension Tubes

5-Part Set, Male and Female Bayonet, 5mm, 15mm, and 30 mm Original Ihagee Tube Set . . . . .	11.95 + 35¢
Independent Make Tube Set . . . . .	7.65 + 35¢
Automatic Tubes (automatic lenses remain automatic) 3-part set (each part has its own male bayonet) . . . . .	19.95 + 65¢
Twin Cable Release, trips automatic lens and shutter, Budget Quality . . . . .	6.85 + 20¢
New German Precision Model . . . . .	9.70 + 25¢
Macrolite: Direct Reading Exposure Factor Screen. Use it in Prism or Model N Waistlevel Finder .	17.85 + 25¢
Travemat BTL System, New Model, Gives you the correct exposure for close-up work because it sees the exact amount of light that will reach the film. No calculation, no compensation, regardless of extension . . . . .	49.50 + 1.35

## Close-up Lenses

Set of 3, consisting of +1, +2, +3. Builds up to +4, +5, +6. High quality Optical Lenses, coated, in metal screw-in mount: Series VII (requires Filter Adapter) . . . . .	12.50 + 45¢
49mm (Screws directly into Pancolar, Tessar) .	12.50 + 45¢
Series VII Drop-in Plus-Ten Close-Up Lens for ultra close-up work (requires Filter Adapter) . .	5.95 + 25¢

## Short-Barrel Lenses, for use in Bellows:

135mm F4.5 preset German Schacht Travenon . .	19.95 + 95¢
---	-------------

## Macro Lenses:

35mm F2.8 gen. Jena Macro Flektogon with self- compensating diaphragm, fully automatic . . . .	89.50 + 1.25
135mm F2.8 fully automatic Steinheil Macro-S .	159.50 + 1.25
40mm F2.8 Macro—Kilar, limited supply . . . . .	\$89.50 + 1.25

Special Ultra Close-Up Lens: 22mm F2.8 Macro Doryt. Fix Focus (fixed at 1½ times life size). Complete with Exakta Bayonet Mount . . . . .	12.50 + 65¢
---	-------------

## CAMERA CASES, LENS CASES, GADGET BAGS, ETC.

### Exakta Ever-Ready Cases:

Exakta Case, non-detachable front . . . . .	7.85 + 95¢
Exakta Case, detachable front . . . . .	9.85 + 95¢
Exakta Case, Metal Trim, detachable front . . . . .	14.50 + 95¢
Exakta Case, extra high top (BTL Meter) . . . . .	17.85 + 95¢

### Lens Cases:

Hard Cases for Lenses up to 135mm . . . . .	4.95 + 65¢
Cases for larger lenses, etc. . . . .	request prices

### Lens Pouches:

Small Velvet Lined Drawstring Pouch . . . . .	2.95 + 25¢
Medium Size Velvet Lined Drawstring Pouch . . . .	3.95 + 25¢
Large Velvet Lined Drawstring Pouch . . . . .	4.95 + 25¢

### Equipment Cases, Gadget Bags, etc.:

Topgrain Cowhide Bag 12 x 10 x 6 . . . . .	29.95 + 1.65
"SAFARI" Foam Fitted Attache Case . . . . .	19.95 + 1.65
Aluminum Foam Fitted Case . . . . .	47.50 + 1.95
"STATUS" Pro Bag . . . . .	39.95 + 2.35
"STATUS" Pro Bag, Super Size . . . . .	69.50 + 2.95

### Miscellaneous:

Vinyl Accessory Bag, Close-Out, our choice . . . . .	2.00 + 35¢
Filter Pouch, for 4 Filters in easy view . . . . .	1.95 + 25¢
Case for Heliotron Perma Strobe . . . . .	3.95 + 35¢
Neckchain, chrome Snakechain . . . . .	3.25 + 25¢
Neckstrap, Leather, flat . . . . .	1.95 + 15¢
Neckstrap, Leather, braided, round . . . . .	2.95 + 15¢
Shoulder Pads, for camera case strap, Pak of 3 . . . .	1.85 + 15¢
Shoulder Pads, Jumbo Size, each . . . . .	1.85 + 25¢

## FLASH EQUIPMENT:

Heliotron Perma Power Strobe, with case . . . . .	33.90 + 1.25
Unomat Model 1000 Strobe Unit . . . . .	39.95 + 1.25
Unomat Model 6000 Strobe Unit with Slave . . . . .	59.50 + 1.95
Hershey-Introl Ringlight with Power Source . . . . .	98.50 + 1.35
Fanfold BC Flashgun (for flash bulbs) . . . . .	6.95 + 65¢
Fanfold BC Gun with "Bounce" Feature . . . . .	8.95 + 65¢
Cube Gun with Battery (cubes not included) . . . . .	5.20 + 65¢
Steady-Trip Flash Bracket . . . . .	3.95 + 25¢
Flip-Trip Flash Bracket with Swivel . . . . .	5.95 + 35¢
Accessory Shoe, Original Ihagee . . . . .	3.95 + 15¢
Accessory Shoe, independent make . . . . .	1.95 + 15¢
Accessory Shoe for Bottom of Camera . . . . .	1.85 + 15¢
Grip-O-Matic Flash Bracket with Cable Tripper . . . .	4.95 + 45¢
Sky-High Flash Bracket with Extension Cord . . . . .	7.90 + 55¢
Twin Flash Bracket, internally wired . . . . .	4.95 + 45¢
Hot Shoe Conversion Assembly . . . . .	2.85 + 15¢
PC Twin Outlet Converter, Pak of 2 . . . . .	1.85 + 15¢

## EXPOSURE METERS:

Travemat BTL System, New Model . . . . .	49.50 + 1.35
Toshiba CdS Exposure Meter, w/battery & Case . .	16.95 + 95¢

**FILTERS, POLARIZERS, ETC.:**

- Filters, 49mm Screw-in Size . . . . . 4.95 + 25¢
- Rotating Polarizers, 49mm Screw-in Size . . . . . 10.85 + 25¢
- Filters, Polarizers, other sizes . . . . . request prices
- Grid Filter Disc, Series VII . . . . . 5.95 + 25¢
- Soft Focus Disc, Ser. VII . . . . . 5.95 + 25¢
- Neutral Density Filter, Ser. VII . . . . . 5.95 + 25¢
- Plus Ten Auxiliary Close-Up Lens, Ser. VII . . . . . 4.95 + 25¢
- Close-Up Lens Set, 3 Lenses build up from +1 to +6
  - 49mm Screw-in Size, with Leather Case . . . . . 11.95 + 35¢
  - Series VII (threaded), with Leather Case . . . . . 11.95 + 35¢
- Filter Pouch, takes 4 Filters in full view . . . . . 1.95 + 25¢

**FILTER ADAPTERS, SHADES, ETC.:**

- Ser. VII Filter Adapters, 46mm to 58mm . . . . . 4.50 + 25¢
- Ser. VII Sunshade, to fit above adapters . . . . . 4.95 + 25¢
- Sunshades, Screw-in, 46mm to 55mm . . . . . 4.95 + 25¢
- Sunshades, Screw-in, 58mm . . . . . 5.95 + 25¢
- Sunshades, Screw-in, 62mm . . . . . 6.95 + 35¢
- Rubber Sunshades, fold back over lens, Ser. VII . . . . . 4.95 + 25¢
- Rubber Sunshades, Screw-in, 46mm to 55mm . . . . . 4.95 + 25¢
- Inst-A-Dapter, converts one mm size to another
  - any combination male/female 49,52,54,55mm . . . . . 2.75 + 25¢
- Metal Lenscaps, Screw-in, Series VII . . . . . 1.95 + 25¢
- Metal Lenscaps, Screw-in, mm sizes, state size . . . . . 1.95 + 25¢

**15 Days Money Back  
on ANY item  
in this folder**

*Better Filters, Better Pictures!*

It doesn't make sense to spend a good deal of money on a highly corrected lens, only to destroy the correction with a poorly made filter! Seymour's-Exakta lets you buy only the most critically selected plano-parallel filters, guaranteed to match the optical performance of the most highly corrected lens.

Huge turnover permits us to buy at very advantageous quantity prices. Satisfied with a small mark-up, we bring you these top quality filters at typical Seymour Prices.

Until last year we sold our Series VII Filters for \$5.95 each. About a year ago we dropped the price to \$4.50. The increased volume encouraged us to make larger commitments which led to better prices from the factory. Now we decided to shave the prices down to an irreducible minimum to make it possible for everybody (and we mean EVERYBODY!) to stock up on all the filters he wants. Look at this price:

Series VII coated  
Filters in sets of 4, each **3<sup>49</sup>** (Singly 3.95)

**Quality Filters at Incredibly Low Prices:**

	Single Filters	Set of 4 Filters	Rotating Polarizer	Neutral d. Grid Disc Soft Disc	Single Close-Up	Set of 3 Close-Up
Series VII Drop-in	3.95	13.95	9.85	5.95	4.50	11.95
49mm Screw-in	4.95	15.95	10.85	6.95	4.95	11.95
46 and 52mm	4.95	15.95	10.85	6.95	5.95	13.95
54 and 55mm	5.45	17.95	11.85	8.95		
58mm	6.45	19.95	12.85	9.95		
62mm	6.95	21.95	13.85	12.50		

Postage: 25¢ for Single Filters; 35¢ for Sets

- Series VII Filter Adapters for Drop-in Filters  
46mm, 49mm, 52mm, 54mm, 55mm . . . . . **4<sup>50</sup>** each
- Series VII Sunshades  
Fits into any of the above adapters . . . . . **4<sup>95</sup>** each
- 49mm Screw-in Shade  
Fits directly into lens . . . . . **4<sup>95</sup>** each

**MISCELLANEOUS EQUIPMENT:**

- Master Showman Projection Pointer . . . . . 6.95 + 45¢
- All Metal Slide Sorter . . . . . 3.95 + 55¢
- Micro-Print, Focusing Magnifier for Enlarger . . . . . 4.95 + 95¢
- Blower Brush, retractable, rubber bulb . . . . . 1.95 + 20¢
- Flat Camera and Lens Dust Brush, Camelshair . . . . . 1.85 + 15¢
- Swivel Brush, Camelshair . . . . . 2.45 + 15¢
- Calipers, German, measures diameter . . . . . 2.85 + 15¢
- Screwdriver Set, 4 different blades . . . . . 1.85 + 15¢
- Miniature Tool Kit . . . . . 1.95 + 25¢
- Pistol Grip with Cable Tripper . . . . . 5.95 + 95¢
- Reloadable Cassettes, Pak of 10 . . . . . 3.50 + 25¢
- Pneumatic Shutter Release, 20 feet . . . . . 5.95 + 25¢
- Pneumatic Shutter Release, 40 inches . . . . . 4.95 + 25¢
- Twin Cable Release Assembly, Budget Model . . . . . 6.85 + 25¢
- Twin Cable Release, New German Precision Model . . . . . 9.70 + 25¢
- Leather Neckstrap, flat . . . . . 1.95 + 15¢
- Leather Neckstrap, braided, round . . . . . 2.95 + 15¢
- Chrome Neckchain, snakechain . . . . . 3.25 + 15¢
- Exakta Rewind Handle for VX, VXIIa . . . . . 2.85 + 25¢
- T Mount Adapter for T-Mount Lenses (Exakta) . . . . . 4.95 + 25¢
- Hot Flash Shoe, with cord . . . . . 2.85 + 15¢
- Cold Flash Shoe with PC Outlet . . . . . 2.45 + 15¢
- Dustcap for Exakta Camera Body . . . . . 1.95 + 15¢
- Rear Lens Cap, Bayonet for Exakta Lenses . . . . . 1.95 + 15¢
- Screw-in Lenscaps, Series VII or custom size . . . . . 1.95 + 15¢
- Permanent Mount Accessory Shoe, Pak of 3 . . . . . 1.85 + 15¢

**SEYMOUR'S-EXAKTA**  
350 West 31 Street, New York, N. Y. 10001  
*Exakta Specialists for over 20 years*

**Sky-High  
Flash Bracket**



This new Flash Accessory was invented by a news photographer who needed the high-angle light to flatter his subjects. For the first time he was able to eliminate the ghastly results of head-on flash. A high angle of light gives the appearance of natural daylight and eliminates the dreaded shadows caused by flash. Gone are the pasty faces, the staring eyes, the harsh contours usually associated with flash pictures. The Sky-High Flash Bracket, extends, telescopes, and folds flat for easy carrying. It attaches to your camera just like an ordinary flash bracket. On top it has a shoe to attach your flash or strobe. Since most flashguns have only a short cord, we recommend a flash extension cord for greatest versatility.

Sky-High  
Flash Bracket  
Extension Cord - \$1.95  
**\$5<sup>95</sup>** +55¢  
Shipp'g

*Buried Treasures*

Many New Items and many Terrific Buys are buried in the small print of this Issue.

Don't miss a single new item! Don't miss the juiciest bargains! Read Every Word!



# Special Inserts Again Available

After a long absence these helpful (so-called "Scientific") Focusing and Viewing Inserts are again available:

Groundglass with Clear Center Spot . . . . .	14.95 + 35¢
Groundglass with Crosshairs . . . . .	14.95 + 35¢
Groundglass with Overall Squares . . . . .	19.50 + 35¢
Clear Glass with Crosshairs . . . . .	14.95 + 35¢
Groundglass with Combination Clear Spot and Crosshairs . . . . .	19.50 + 35¢
Finegrain Groundglass . . . . .	5.95 + 35¢
Clear Glass . . . . .	6.95 + 35¢



**Reloadable Cassettes**  
 10 for 3.50 + 25¢  
 25 for 6.95 + 35¢  
 100 for 24.50 + 45¢

## Seymour's Guaranteed Exakta Repairs

Seymour's-Exakta is fully equipped to handle all repairs on Exakta Cameras. We use original factory parts and factory methods exclusively. Our technicians know what they are doing. All repairs are fully guaranteed for one full year. Cost Estimates are free and given without obligation on your part.

Send your camera by insured parcel post. Attach a tag to the camera itself giving your full name and address and stating briefly but clearly what you would like to have done to your camera. Mark the tag: "Estimate Only."

Most repairs require only ten working days from the time we receive your OK. Some difficult or complicated repairs may take somewhat longer and at certain peak periods we may need a little extra time. Remember that all work is done with our traditional thoroughness: we never rush the work, even during peak periods. Our One-Year Service Guarantee protects you, always.

Send your camera now. We are ready to put it in first class operating cc

# SWAP!

Trade up to the  
**EXAKTA VX-1000TL**  
 Prices are for the exchange of bodies without lenses and finders:  
 Exakta VX-1000 and \$49.50  
 Exakta VXIIB and \$54.50  
 Exakta VXIIa, VX, or V and \$59.50  
 Shipping Charges \$1.95 per camera.  
 Send your camera by insured parcel post.  
 Enclose your order and remittance.



### *Modernize that Old Exakta with a Fully Automatic Lens*

If you want a good sharp fully automatic lens to replace an older non-automatic lens, let me recommend the new fully automatic 50mm F2.8 Meyer Optik Domiplan. It's yours, brand new, for just \$18.95 + 95¢ Shipping Charges.

50mm F2.8 Fully Automatic Meyer Optik Domiplan \$18.95 + 95¢ Shipping Charges.

## Exakta Eveready Cases

A case for every taste. A case for every pocketbook. A case for every model camera, for every combination of body, finder, and lens. As Exakta Specialists, Seymour's-Exakta brings you the greatest choice of camera carrying cases. We have more than a thousand cases in stock. Dress up your camera! Protect your camera! Buy a new case for it!

#66 Standard Exakta Case, non-detachable front	\$7.85 + 95¢
#69 Deluxe Exakta Case, detachable front	\$9.85 + 95¢
#77 Deluxe Exakta Case, metal trim, detachable front	\$14.50 + 95¢
#83 Deluxe Exakta Case, Metal Trim, detachable front Extra High Top (takes Exakta with BTL Meter)	\$17.85 + 95¢

Please order by Number and Description.

**SEYMOUR'S-EXAKTA**  
 350 W 31 St., New York, N. Y. 10001  
 Exakta Specialists for over 20 Years

BULK RATE  
 U. S. POSTAGE  
**PAID**  
 Permit No. 50  
 Brooklyn, N. Y.